

Instruction Manual

α pha-DO2000

Dissolved Oxygen Controller/Transmitter



EUTECH
INSTRUMENTS

Technology Made Easy...

ISO 9001
CERTIFIED

68X216835 Rev 1 Nov 05

Preface

This manual serves to explain the use of the α DO 2000 Series. The manual functions in two ways, firstly as a step by step guide to help the user operate the instrument, and secondly as a handy reference guide. This instruction manual is written to cover as many anticipated applications of the α DO 2000 as possible. If you have any doubts concerning the use of the instrument, please do not hesitate to contact the nearest Eutech Instruments Authorised Distributor.

The information presented in this manual is subject to change without notice as improvements are made, and does not represent any commitment whatsoever on the part of Eutech Instruments.

Eutech Instruments will not accept any responsibility for damage or malfunction of the unit due to improper use of the instrument.

Copyright ©2005 All rights reserved.

Eutech Instruments Pte Ltd

Safety Information

This Controller/ Transmitter shall be installed and operated only in the manner specified in the Instruction manual. Only skilled, trained or authorised person should carry out installation, setup and operation of the instrument.

Before powering up the unit, make sure that power source it is connected to, is as specified in the top label. Failure to do so may result in a permanent damage to the unit.

The unit has live and exposed parts inside. If it has to be opened, make sure that the power to the unit is off and disconnected.

The unit is Fuse protected. In the event the fuse has to be replaced, use only those as specified in the manual.

The degree of protection against electric shock will be achieved only by observance of the corresponding installation rules.

TABLE OF CONTENTS

1	INTRODUCTION	1
1.1	AT THE VERY BEGINNING	1
1.2	INTENDED USE	1
1.3	SAFETY INSTRUCTIONS	2
1.4	PUTTING OUT OF SERVICE / CORRECT DISPOSAL OF THE UNIT	2
2	PRODUCT DESCRIPTION	3
2.1	DESCRIPTION OF UNIT	3
2.2	MEASUREMENT AND CONTROL SYSTEM	4
2.3	UNIT OVERVIEW	5
2.3.1	<i>Display Overview</i>	6
2.3.2	<i>Key functions</i>	6
2.3.3	<i>LED indicators</i>	7
2.3.4	<i>Security codes</i>	7
2.3.5	<i>Menu overview</i>	8
3	ASSEMBLY AND INSTALLATION	9
3.1	MOUNTING THE UNIT	9
3.2	CONNECTION DIAGRAM	10
4	NORMAL OPERATION	12
4.1	MEASUREMENT MODE	12
5	CALIBRATION MODE	13
5.1	ENTERING CALIBRATION MODE	13
5.2	DISSOLVED OXYGEN CALIBRATION IN MG/L OR PPM OF OXYGEN	14
5.2.1	<i>One-Point Calibration</i>	14
5.2.2	<i>Two-Point Calibration</i>	15
5.3	DISSOLVED OXYGEN CALIBRATION IN % SATURATION OF OXYGEN	17
5.3.1	<i>One-Point Calibration</i>	17
5.3.2	<i>Two-Point Calibration</i>	18
5.4	VIEW PROBE CONDITION	19
6	SETUP MODE	20
6.1	ENTER SETUP MODE	20
6.2	OFFSET, SALINITY AND PRESSURE COMPENSATION (OFS) SUB-FUNCTION	21
6.3	SETTING TEMPERATURE (SET °C/°F) SUB-FUNCTION	23
6.4	CONTROL RELAY A / RELAY B (SP1/SP2) SUB-FUNCTION	24
6.5	CONTROLLER (CNTR) SUB-FUNCTION	26
6.6	CURRENT OUTPUT 1 (CUR 1) SUB-FUNCTION	29
6.7	CURRENT OUTPUT 2 (CUR 2) SUB-FUNCTION	30
6.8	WASH RELAY (WASH) SUB-FUNCTION	31
6.9	CONFIGURATION (CNFG) SUB-FUNCTION	32
6.10	CALIBRATION (CAL) SUB-FUNCTION	33
7	RELAY MODES	34
7.1	VIEW RELAY SET POINTS	34
7.2	MANUAL RELAY MODE	35
8	TECHNICAL SPECIFICATIONS	36
8.1	MEASUREMENT AND COMPENSATION	36
8.2	SET-POINT AND CONTROL FUNCTION – RELAY 1 & RELAY 2	36
8.3	WASH FUNCTION – WASH RELAY	37
8.4	ALARM FUNCTION – ALARM RELAY	37
8.5	TRANSMITTER FUNCTION	37
8.6	VOLTAGE OUTPUT & HOLD FUNCTION SWITCH	38

8.7	DISPLAY	38
8.8	POWER SUPPLY	38
8.9	ELECTRICAL DATA AND CONNECTIONS	38
8.10	MECHANICAL SPECIFICATIONS	38
8.11	ELECTROMAGNETIC COMPLIANCE (EMC) SPECIFICATIONS	38
8.12	ENVIRONMENTAL CONDITIONS.....	38
9	ACCESSORIES.....	39
9.1	REPLACEMENT UNIT.....	39
9.2	ASSEMBLY ACCESSORIES	39
10	GENERAL INFORMATION.....	40
10.1	WARRANTY	40
10.2	PACKAGING / SCOPE OF DELIVERY.....	40
10.3	RETURN OF GOODS.....	40
10.4	GUIDELINES FOR RETURNING UNIT FOR REPAIR	40
10.5	MAINTENANCE AND CLEANING	40
11	APPENDICES	41
11.1	APPENDIX 1 – UNIT FUSE AND JUMPER SETTINGS.....	41
11.2	APPENDIX 2 – SALINITY VS TEMPERATURE (@ 760 MMHG).....	42
11.3	APPENDIX 3 – SIMPLE EXPLANATION ON THE FUNCTION OF HYSTERESIS	43
11.4	APPENDIX 4 – GENERAL INSTRUCTIONS CONCERNING CONTROLLER SETTING	44
11.4.1	<i>Control characteristic of Controllers used as limit value switch</i>	<i>44</i>
11.4.2	<i>Control characteristic of P-Controllers as proportional controller.....</i>	<i>44</i>
11.4.3	<i>Control characteristic of PI-Controllers as proportional integral controller.....</i>	<i>44</i>
11.4.4	<i>Control signal of Pulse length Controllers.....</i>	<i>45</i>
11.4.5	<i>Control signal of Pulse Frequency Controllers.....</i>	<i>46</i>
11.5	APPENDIX 5 – ABBREVIATIONS USED IN MENU DISPLAYS	47

1 INTRODUCTION

1.1 At the very beginning

We thank you for having purchased the αalpha DO 2000.

The construction of the αalpha DO 2000 employs leading edge technology and complies with safety regulations currently in force. Notwithstanding this, improper use could lead to hazards for the user or a third-party, and/or adverse effects on the plant or other equipment. **Therefore, the operating instructions must be read and understood by the persons involved before work is started with the αalpha DO 2000.**

Eutech Instruments do not accept any liability for damage that may arise from neglecting information given in this manual.

This instruction manual identifies safety instructions and additional information by means of the following symbols:



This symbol draws attention to **safety instructions and warnings of potential danger** which, if neglected, could result in injury to persons and/or damage to property.



This symbol identifies **additional information and instructions** which, if neglected, could lead to inefficient operation and possible loss of production.

The instruction manual must always be stored close at hand, in a place accessible to all people working with the αalpha DO 2000.

If you have questions, which are not or insufficiently answered in this instruction manual, please contact your supplier. They will be glad to assist you.

1.2 Intended use

The αalpha DO 2000 is intended solely for dissolved oxygen and temperature measurement, as described in this instruction manual.

Any other use, or use not mentioned here, that is incompatible with the technical specifications is deemed inappropriate. The operator is solely responsible for any damage arising from such use.

Other prerequisites for appropriate use include:

- observing the instructions, notes and requirements set out in this instruction manual.
- observing all local safety regulations concerning safety at work.
- observing all information and warnings in the documentation dealing with the products used together with the transmitter (housings, sensors, etc.).
- observing the prescribed environmental and operational conditions.

1.3 **Safety instructions**

The αlpha DO 2000 should be installed and operated only by personnel familiar with the transmitter and who are qualified for such work.

A defective transmitter must neither be installed nor put into service.

The αlpha DO 2000 must only be operated under the specified operating conditions

The αlpha DO 2000 must not be repaired by the customer.



The αlpha DO 2000 must only be opened to replace the unit fuse or to set the jumper for Pt100/Pt1000 temperature sensor. This work must be carried out only by personnel familiar with the transmitter and who are qualified for such work. Make sure the mains cable is separated from the power supply before opening the unit.

No modifications to the αlpha DO 2000 are allowed. The manufacturer/supplier accepts no responsibility for damage caused by unauthorised modifications. The risk is borne entirely by the user.

1.4 **Putting out of service / Correct disposal of the unit**

Putting out of service

- First disconnect the unit from the mains, then undo all electrical connections.
- Remove the unit from the wall / panel.

Correct disposal of the unit

When the transmitter is finally taken out of service, observe the local environmental regulations for correct disposal or send the transmitter to your local distributor, they will take care of proper disposal.

2 PRODUCT DESCRIPTION

2.1 Description of unit

The alpha DO 2000W is used for measuring dissolved oxygen and temperature values. The dissolved oxygen values can be measured using industrial dissolved oxygen sensors. The temperature values can be measured using 2-wire / 3-wire Pt100 /Pt1000 sensors. The controller / transmitter can be used for applications such as water treatment and monitoring, galvanic-decontamination, chemical processing, food processing, clean or wastewater control and neutralization processes.

This controller/transmitter has many user-friendly and safety features which include:

- Push-button for calibration and sensor offset adjustment from the keypad.
- Built-in non-volatile memory to ensure that calibration and other information are not erased if power supply fails.
- Menu-driven program that simplifies set-up.
- Automatic temperature compensation (ATC).
- Manual temperature compensation setting without the ATC probe, with independent setting for calibration and process temperature.
- Two galvanically isolated current outputs 0/4...20mA.
- Two switching contacts as set-point relays.
- 0 to 2000 seconds time delay adjustment on all relays – minimizes false alarms.
- Separately adjustable high and low set-point hysteresis (dead bands) prevent chattering of relays around the set points.
- Three control modes: limit controller, P controller and PI controller (P/PI controller as pulse length or pulse frequency).
- Large dual display LCD for easy reading with clear multiple annunciators, alarm status, operational and error messages.
- Separate alarm relay alerting you to set point limits exceeded for a certain time and if the Pt100/Pt1000 wires are broken or disconnected during the ATC function.
- Wash relay.
- Hold function to freeze output current (0/4...20mA) and release control relays.
- LED indicators signal control activities to visually monitor transmitter status from a distance.
- Protection against electromagnetic interference.
- Back lit and UV light protected LC display.

2.2 Measurement and control system

A typical measurement system consists of:

- A dissolved oxygen process transmitter
- A dissolved oxygen sensor with integrated or separate temperature sensor Pt100/Pt1000.
- An appropriate measurement cable
- An immersion, flow or process assembly
- A final control element such as pump or valve
- A chart recorder

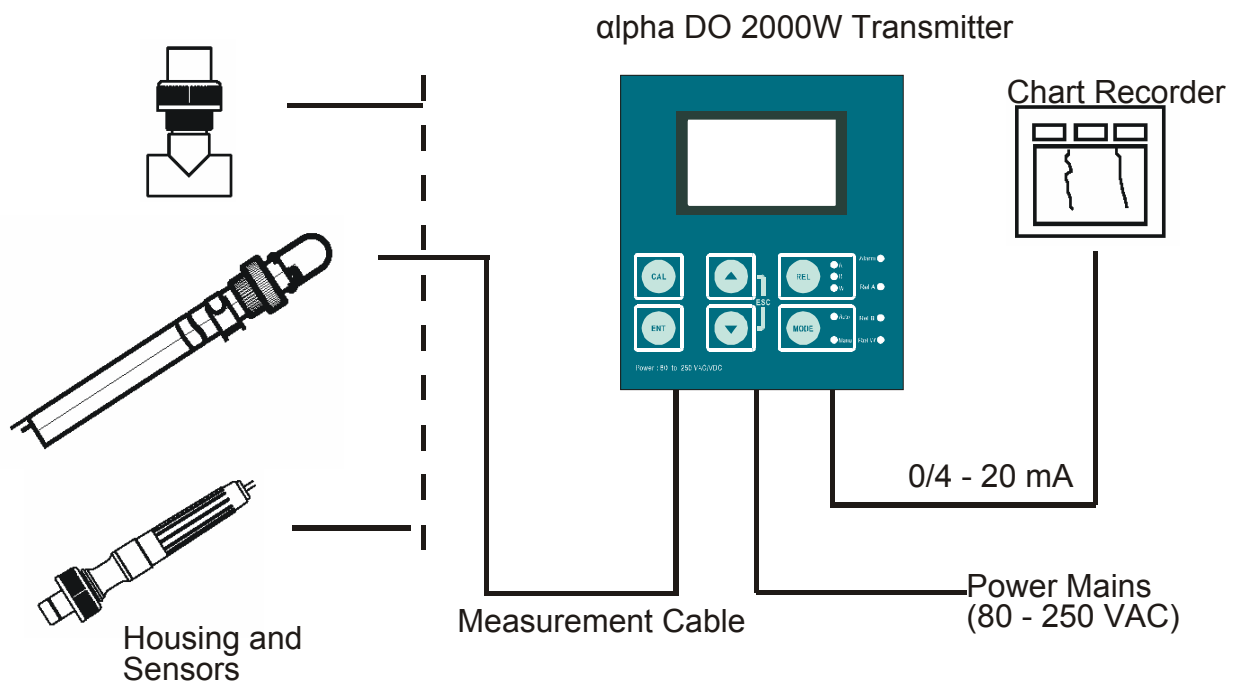

2.3 **Unit overview**
Wall mounting version

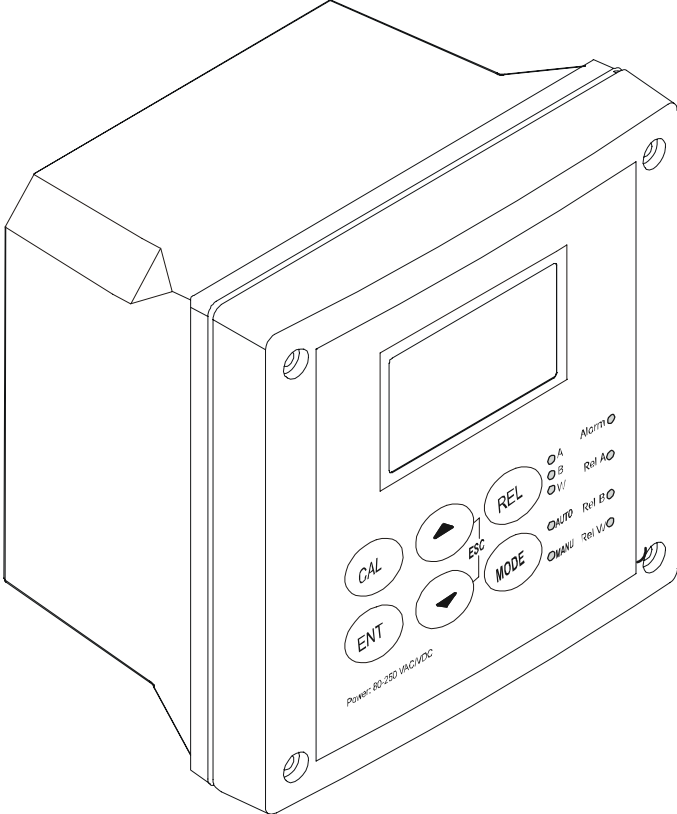

2.3.1 Display Overview

The LC display shows two alpha-numerical fields for parameters and measured values as well as various mode and status indicators.

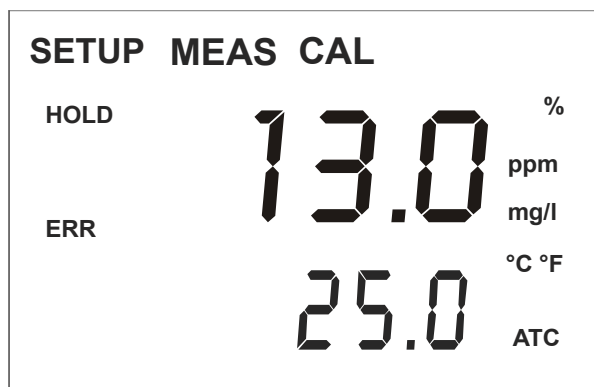

Mode indicators:

MEAS: measurement mode

SETUP: Set-up mode

CAL: Calibration mode







Status indicator:

HOLD: Unit in "HOLD" mode

ATC: Visible in ATC (Automatic Temperature Compensation) mode. Not visible in the Manual Temperature Compensation mode. "ATC" flashes if the temperature probe is faulty in its ATC mode

ERR: Error indicator

2.3.2 Key functions

Key	Description
	Enter Calibration mode (requires access code)
	Enter Set-up mode (requires access code) Access sub functions (parameters) within a function group of Set-up mode Confirm (store) set-up parameters and numerical values Start/Confirm calibration in Calibration mode.
	Select function group in the Set-up mode. Set parameters and numerical values (if key is pressed continuously, the setting speed increases).
	Control the relays in MANUAL relay operation. Returns to "Measurement mode" when both keys are pressed simultaneously.
	Display limit values for SP1 and SP2 and settings for wash contact in AUTO relay operation. Toggle between RELAY A, RELAY B or Wash relay in MANUAL relay operation
	Toggle between AUTO & MANUAL relay operation modes. (requires access code to switch to MANUAL relay operation mode)

2.3.3 LED indicators

Relay indicators



- A
- B
- W

If REL key is pressed the LED (A, B or W) indicates to which Relay (A, B or Wash) the displayed limit values refer.

Relay mode indicators

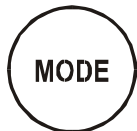

- Auto
- Manu

Auto LED lights if relay operation is set to automatic mode. Manu LED lights if relay operation is set to manual mode.

Relay status indicators

Alarm ●

This LED lights if limit value is exceeded or the ATC probe fails.

Rel A ●

This LED lights green if measured value is within the limit for Relay A or lights red if measured value exceeds limit.

Rel B ●

This LED lights green if measured value is within the limit for Relay B or lights red if measured value exceeds limit.

Rel W ●

This LED lights if cleaning cycle is on.

2.3.4 Security codes

The access to **Calibration mode**, **Setup mode** and **Manual relay operation mode** is protected with security codes. The security codes are set at the factory and cannot be changed by the user. The following security codes are used:

Security code	Mode/Description
000	View only mode/ to view settings
11	Calibration mode/ to start calibration
22	Setup mode/ to configure parameters
22	Manual relay operation mode/ to switch to relay operation mode from AUTO to MANUAL

2.3.5 Menu overview

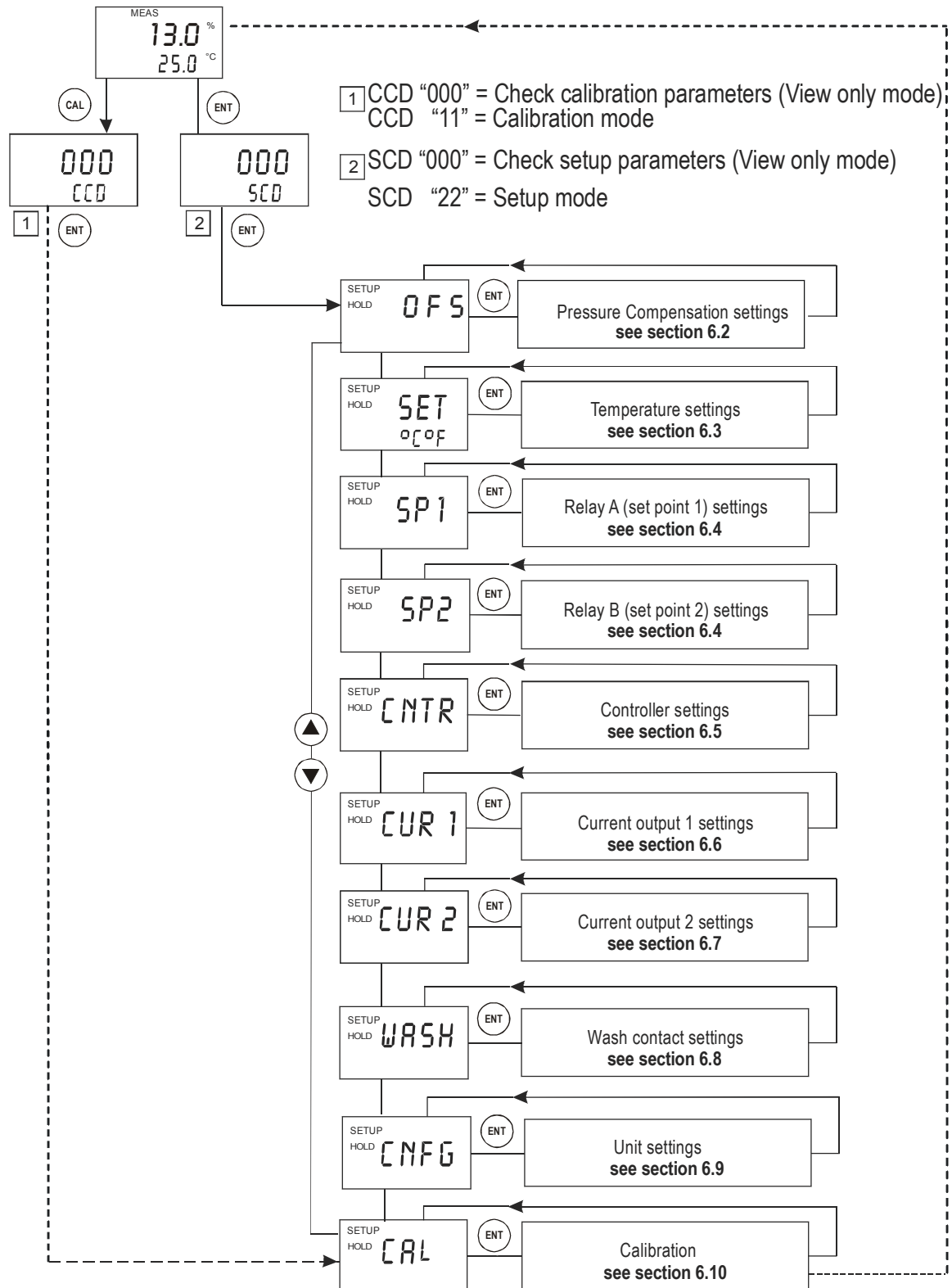

3 ASSEMBLY AND INSTALLATION

3.1 Mounting the unit

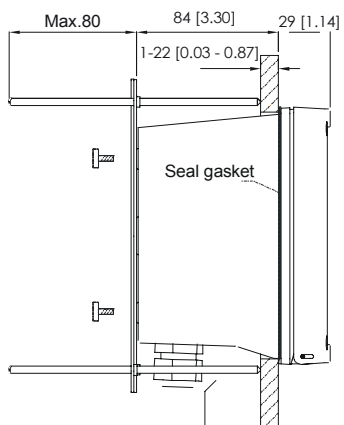
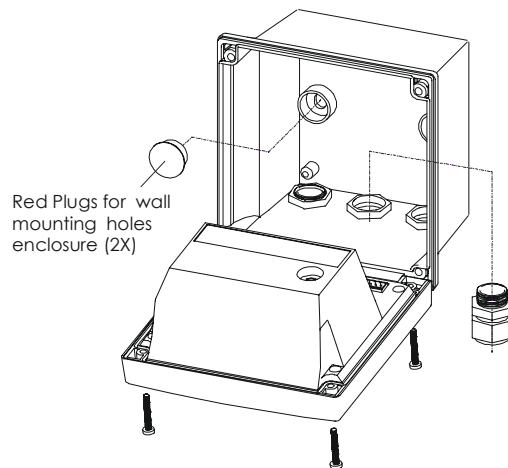
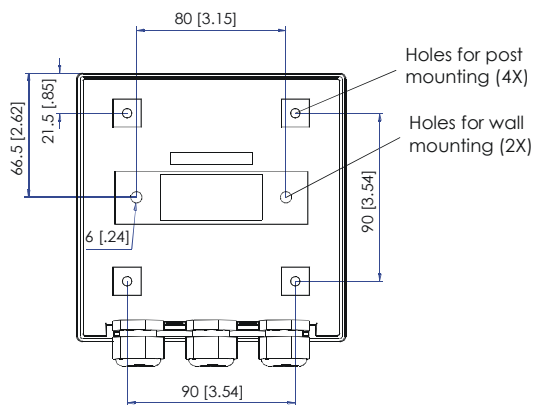
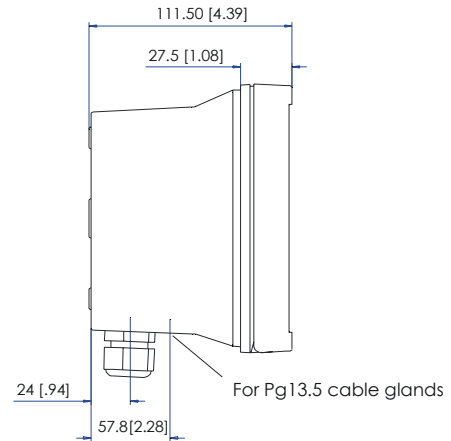
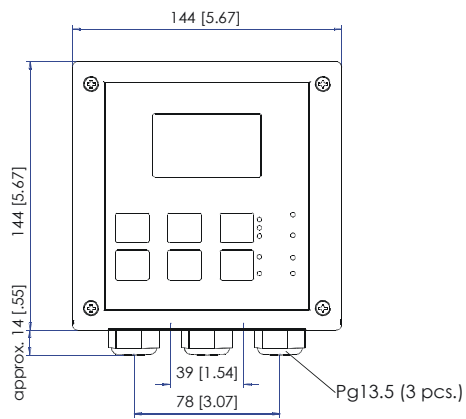

Threaded rod for panel mounting

Unit:
MM [INCH]

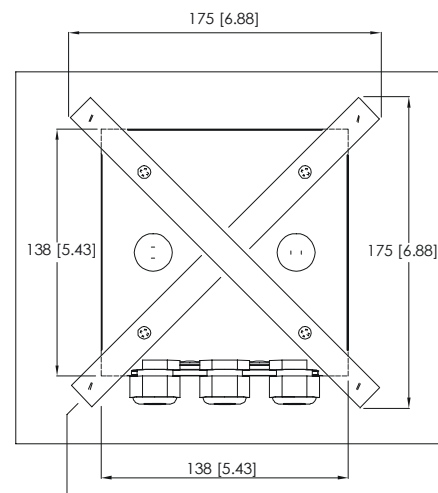

Transmitter housing for wall mounting: protection class IP 66

3.2 Connection Diagram



Caution: Ensure electrical mains are disconnected before proceeding.

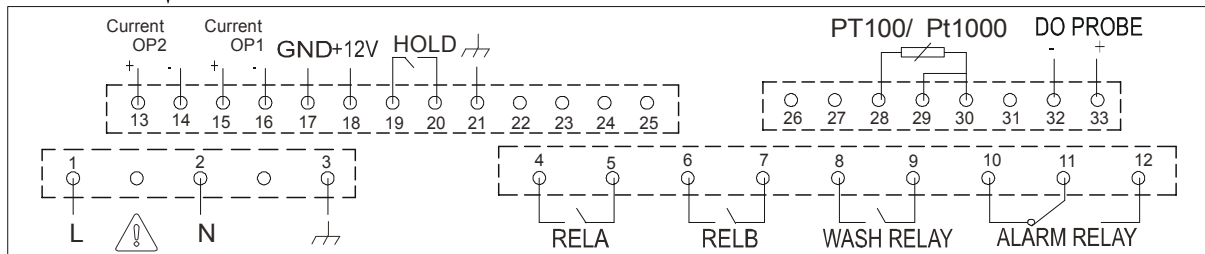
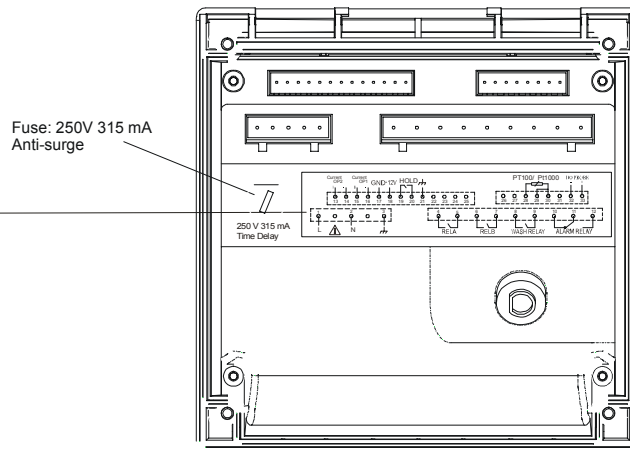

Connections for wall mounting version

1.	AC mains live wire	18.	12V output Power supply
2.	AC mains neutral wire	19.	Hold Function
3.	AC mains protective earth wire	20.	Hold Function
4.	Relay A (SP 1)	21.	Earth ground
5.	Relay A (SP 1)	22.	no connection
6.	Relay B (SP 2)	23.	no connection
7.	Relay B (SP 2)	24.	no connection
8.	Wash relay	25.	no connection
9.	Wash relay	26.	no connection
10.	Alarm relay (NC)	27.	no connection
11.	Alarm relay common	28.	Temperature ground
12.	Alarm relay (NO)	29.	Temperature Sense
13.	4-20 mA temperature output, +ve terminal	30.	Temperature Input
14.	4-20 mA temperature output, -ve terminal		(Short to terminal 29 if using 2- wire RTD)
15.	4-20 mA DO output, +ve terminal	31.	no connection
16.	4-20 mA DO output, -ve terminal	32.	DO input, Anode, -ve terminal
17.	12V output ground	33.	DO input, Cathode, +ve terminal



IMPORTANT: The Alarm relay functions as an “Active Low” device i.e. it switches OFF under Alarm condition. Therefore the Alarm display device should be connected to the ‘NC’ contacts of the relay (10 & 11).



NOTE:

- a) Switch or circuit breaker shall be included in the building installation.
- b) It shall be in close proximity to the equipment and within easy reach of the operator.
- c) It shall be marked as the disconnecting device for the equipment.
- d) The internal circuitry shall not be accessible after installation. The internal circuitry must be protected by a supplementary insulation in the form of covers, enclosures or similar.

4 NORMAL OPERATION

4.1 Measurement mode

When the controller/transmitter is powered on, the display first shows all segments briefly, after which the controller/transmitter automatically enters into the **Measurement mode**.



Please note: To guarantee accurate readings the measuring system (transmitter and sensor) must be calibrated.



The mode indicator "**MEAS**" at the top of the display indicates that the transmitter is in Measurement mode. The upper alpha-numerical display shows the measured dissolved oxygen value, while the lower display shows the temperature value.

From Measurement mode you can access **Calibration mode** and **Setup mode** by pressing the CAL key or ENT key followed by the corresponding security code. For detailed information refer to **section 5 "Calibration mode"** or **section 6 "Setup mode"**, respectively.

By pressing the **REL** key in Measurement mode you can view the actual relay set points. By pressing the **MODE** key followed by the corresponding security code in Measurement mode you can switch relay operation mode from automatic to manual.

For detailed information refer to **section 7 "Relay Modes"**.

5 CALIBRATION MODE

You can access the Calibration mode directly from the Measurement mode by pressing the CAL key and entering the Calibration security code “11”. Calibration mode may also be accessed via the Setup mode (see section 6.1).

5.1 Entering Calibration mode

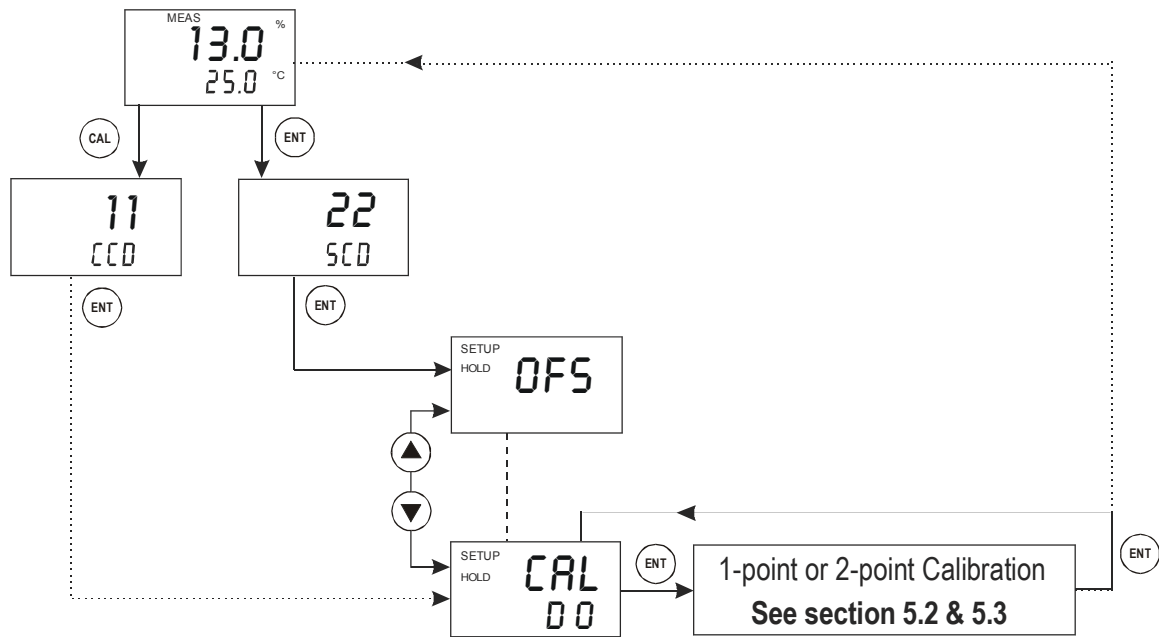

While in Measurement mode **press the CAL key** (direct access) or **ENT key** (access via Setup mode).

- If **CAL key** was pressed: The display prompts you to enter the calibration security code (CCD). **Press the ▲ or ▼ key** to set the calibration security code to “11”, and then **press the ENT key** to confirm the calibration security code.
- If **ENT key** was pressed: The display prompts you to enter the security code (SCD). **Press the ▲ or ▼ key** to set the security code to “22”. **Press the ENT key** to confirm the security code, and then **press the ▲ or ▼ key** to select the calibration sub-function.

The display shows “CAL DO”. To start calibration, refer to section 5.2.



Note: to exit Calibration mode at any time **press the ▲ and ▼ keys simultaneously** (escape). The transmitter returns to the Measurement mode and the old calibration values remain active. The calibration security code automatically resets from “11” to “000” after the transmitter returns to Measurement mode.



Note: The calibration is always carried out in the units (mg/l or ppm or %) selected in setup mode. The DO controller/transmitter allows a 1-point or 2-point calibration.

5.2 Dissolved oxygen Calibration in mg/l or ppm of oxygen

This transmitter features a one-point or two-point calibration for dissolved oxygen. If the unit of measure is set to mg/l (default) or ppm, then the calibration is also carried out in mg/l or ppm.

5.2.1 One-Point Calibration

The one-point calibration is done at high-point (full scale of the probe) using 8.24 mg/l of dissolved oxygen solution.

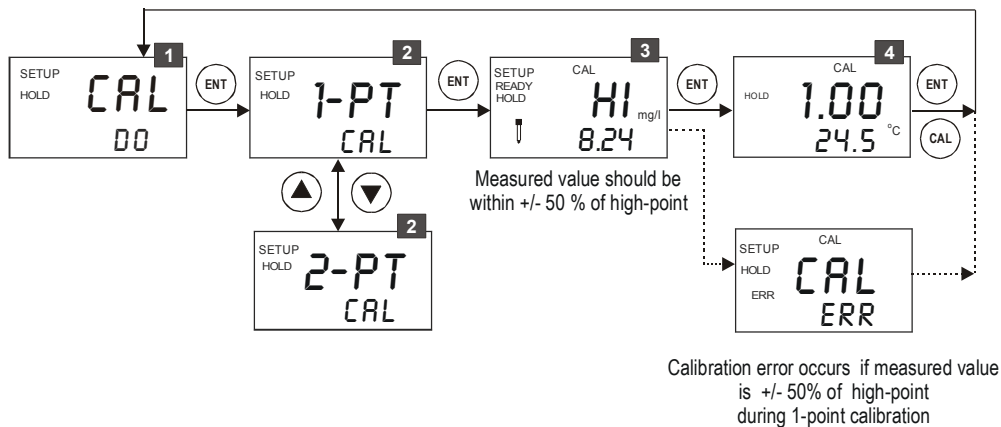

1. **Enter Calibration mode** as described in section 5.1. The display shows “**CAL DO**”. **Press the ENT key** to start calibration.
2. The display shows “**1-PT CAL**” by default. If “**2-PT CAL**” is shown, use **▲ or ▼ keys** to select one-point “**1-PT CAL**” dissolved oxygen calibration. **Press the ENT key** to confirm the one-point selection.

The upper display shows “**HI**”. To begin calibration, allow the probe to equilibrate in a solution containing **8.24 mg/l** of dissolved oxygen. The “**CAL**” annunciator & Electrode indicator flashes in the display. The lower display shows the measured value of dissolved oxygen of the solution. When reading is stable, the “**READY**” annunciator is displayed. Use **▲ or ▼ keys** to adjust the lower display value to “**8.24 mg/l**”.



Note: The controller allows adjusting only up to $\pm 50\%$ of the measured value using **▲ or ▼ keys**

Press the ENT key to confirm the value.



Note: If the measured value is not within $\pm 50\%$ of the high-point value (8.24 mg/l), the controller does not accept the high-point calibration and displays calibration error “**CAL ERR**”.



Note: If calibration error occurs, the controller displays “**CAL ERR**” for a few seconds and quits from calibration mode, retaining previously set calibration values, if any. The controller returns back to the “**CAL DO**” **Setup menu** (if you had accessed calibration mode via Setup mode) or to the **Measurement mode** (if you had accessed calibration mode directly, pressing “**CAL**” key).

If the calibration is successful, controller automatically calculates and displays the current condition of the probe in the upper display. The measured temperature is shown in the lower display.

Press the ENT key (or CAL key). The calibration is completed and the controller exits to the “CAL DO” Setup menu (if you had accessed calibration mode via Setup mode) or to the **Measurement mode** (if you had accessed calibration mode directly, pressing “CAL” key).

5.2.2 Two-Point Calibration

The two-point calibration is carried out at Lo-point, (zero dissolved oxygen solution) and then at Hi-point (full scale of the probe).

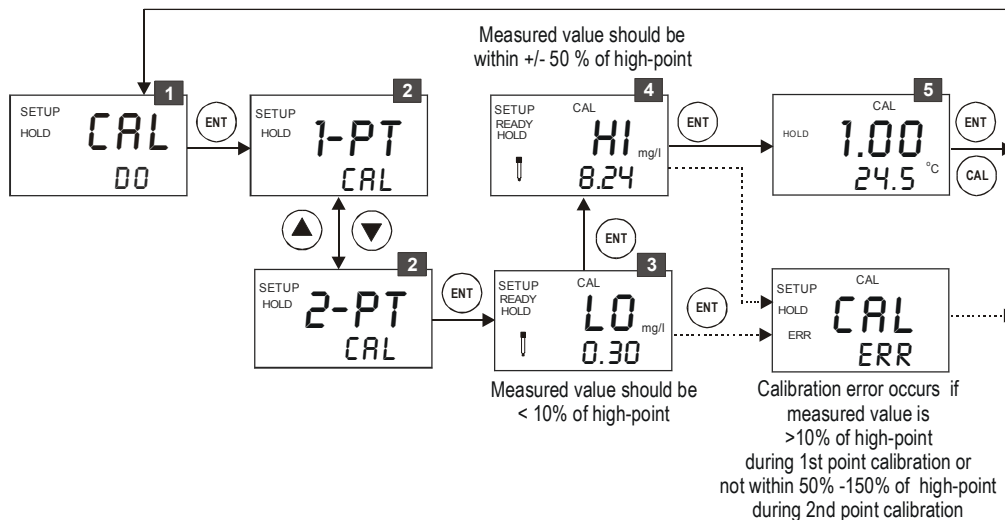

1. **Enter Calibration mode** as described in section 5.1. The display shows “CAL DO”. **Press the ENT key** to start calibration.
2. The display shows “1-PT CAL” by default. Use **▲ or ▼ keys** to select two-point “2-PT CAL” dissolved oxygen calibration. **Press the ENT key** to confirm the two-point selection.
3. The upper display shows “LO”. Immerse the probe in 0% dissolved oxygen solution and allow it to stabilize. The “CAL” annunciator & Electrode indicator flashes in the display. The lower display shows the measured value of dissolved oxygen of the solution. When reading is stable, the “READY” annunciator is displayed.

Press the ENT key to confirm the value.



Note: If the measured value is < 10% of high-point, the controller will accept the Lo-point calibration (0.00 mg/l or ppm) and switches to the second point (High-point)



Note: If the measured value is > 10% of high-point, the controller will not accept the Lo-point calibration and displays calibration error “CAL ERR”.



Note: If calibration error occurs, the controller displays “CAL ERR” for a few seconds and quits from calibration mode, retaining previously set calibration values, if any. The controller returns back to the “CAL DO” Setup menu (if you had accessed calibration mode via Setup mode) or to the **Measurement mode** (if you had accessed calibration mode directly, pressing “CAL” key).

4. If the Lo-point calibration is successful, the controller switches to the high-point calibration. The upper display shows "HI". Take the probe out of the 0% oxygen solution and immerse it in a higher dissolved oxygen concentration (**8.24 mg/l**) solution. The "CAL" annunciator & Electrode indicator flashes in the display. The lower display shows the measured value of dissolved oxygen of the solution. When reading is stable, the "READY" annunciator is displayed. Use **▲** or **▼** keys to adjust the lower display value to the correct value.



Note: The controller allows adjusting only up to $\pm 50\%$ of the measured value using **▲** or **▼** keys

Press the ENT key to confirm the value.



Note: If the measured value is not within $\pm 50\%$ of the high-point value, the controller will not accept the high-level calibration and displays calibration error "CAL ERR".



Note: If calibration error occurs, the controller displays "CAL ERR" for a few seconds and quits from calibration mode, retaining previously set calibration values, if any. The controller returns back to the "CAL DO" Setup menu (if you had accessed calibration mode via Setup mode) or to the **Measurement mode** (if you had accessed calibration mode directly, pressing "CAL" key).

5. If the high-point calibration is successful, controller automatically calculates and displays the current condition of the probe in the upper display. The probe condition is re-determined after each calibration. The measured temperature is shown in the lower display.

Press the ENT key (or CAL key). The calibration is completed and the controller exits to the "CAL DO" Setup menu (if you had accessed calibration mode via Setup mode) or to the **Measurement mode** (if you had accessed calibration mode directly, pressing "CAL" key). to return to the measurement mode (for direct access calibration mode) or to the setup menu (for calibration mode accessed via Setup mode).



Note: When calibrating with manual temperature compensation, the controller automatically changes from the preset process temperature to the calibration temperature. After leaving the Calibration mode, the controller switches back to process temperature (for setting the calibration temperature and the process temperature, see Section 6.3)

5.3 Dissolved oxygen Calibration in % saturation of oxygen

This transmitter features a one-point or two-point calibration for dissolved oxygen. If the unit of measure is set to % (saturation of oxygen), then the calibration is also carried out in %.

5.3.1 **One-Point Calibration**

The one-point calibration is done in air (100% oxygen saturation).

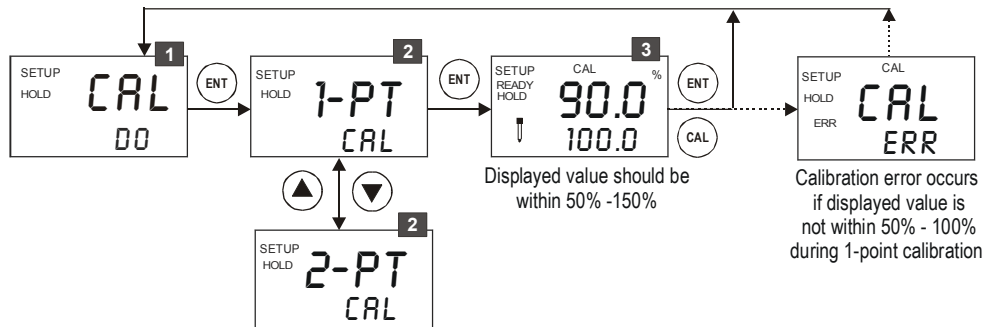

1. **Enter Calibration mode** as described in section 5.1. The display shows “**CAL DO**”. **Press the ENT key** to start calibration.
2. The display shows “**1-PT CAL**” by default. If “**2-PT CAL**” is shown, use **▲ or ▼ keys** to select one-point “**1-PT CAL**” dissolved oxygen calibration. **Press the ENT key** to confirm the one-point selection.
3. The lower display shows “**100.0**”. To begin calibration, allow the probe to equilibrate in air. The “**CAL**” annunciator & Electrode indicator flashes in the display. The upper display shows the measured value of dissolved oxygen of the solution. When reading is stable, the “**READY**” annunciator is displayed.

Press the ENT key (or CAL key) to confirm the reading.



Note: If the measured value is not within 50% -150%, the controller does not accept the 100% calibration and displays calibration error “**CAL ERR**”.



Note: If calibration error occurs, the controller displays “**CAL ERR**” for a few seconds and quits from calibration mode, retaining previously set calibration values, if any. The controller returns back to the “**CAL DO**” **Setup menu** (if you had accessed calibration mode via Setup mode) or to the **Measurement mode** (if you had accessed calibration mode directly, pressing “**CAL**” key).

If the calibration is successful, the controller exits to the “**CAL DO**” **Setup menu** (if you had accessed calibration mode via Setup mode) or to the **Measurement mode** (if you had accessed calibration mode directly, pressing “**CAL**” key).

5.3.2 Two-Point Calibration

The two-point calibration is done with standard D.O buffer of 0% saturation and then in air (100% saturation).

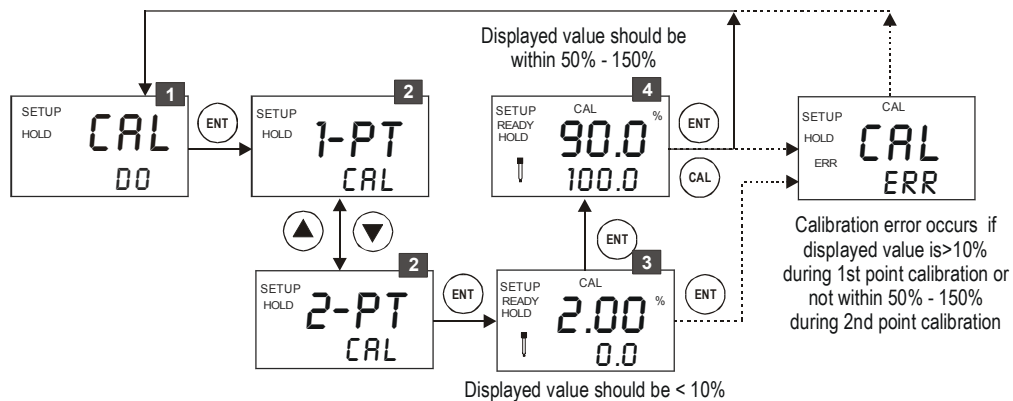

1. **Enter Calibration mode** as described in section 5.1. The display shows “**CAL DO**”. **Press the ENT key** to start calibration.
2. The display shows “**1-PT CAL**” by default. Use **▲** or **▼** keys to select two-point “**2-PT CAL**” dissolved oxygen calibration. **Press the ENT key** to confirm the two-point selection.
3. The lower display shows “**0.0**”. Immerse the probe in 0% standard DO buffer solution and allow it to stabilize. The “**CAL**” annunciator & Electrode indicator flashes in the display. The upper display shows the measured value of dissolved oxygen of the solution. When reading is stable, the “**READY**” annunciator is displayed.

Press the ENT key to confirm the reading.



Note: If the measured value is more than 10%, the controller does not accept the 0% calibration and displays calibration error “**CAL ERR**”.



Note: If calibration error occurs, the controller displays “**CAL ERR**” for a few seconds and quits from calibration mode, retaining previously set calibration values, if any. The controller returns back to the “**CAL DO**” **Setup menu** (if you had accessed calibration mode via Setup mode) or to the **Measurement mode** (if you had accessed calibration mode directly, pressing “**CAL**” key).

4. If the 0% calibration is successful, the controller switches to the second point, which is the 100% saturation of dissolved oxygen. Take the probe out of the 0% oxygen solution, rinse in clean water, dry it and then allow the probe to equilibrate in air. The “**CAL**” annunciator & Electrode indicator flashes in the display. The upper display shows the measured value of dissolved oxygen of the air. When reading is stable, the “**READY**” annunciator is displayed.

Press the ENT key (or CAL key) to confirm the reading.



Note: If the measured value is not within 50% -150%, the controller does not accept the 100% calibration and displays calibration error “**CAL ERR**”.



Note: If calibration error occurs, the controller displays “**CAL ERR**” for a few seconds and quits from calibration mode, retaining previously set calibration values, if any. The controller returns back to the “**CAL DO**” **Setup menu** (if you had accessed calibration

mode via Setup mode) or to the **Measurement mode** (if you had accessed calibration mode directly, pressing “CAL” key).

If the calibration is successful, the controller exits to the “**CAL DO**” Setup menu (if you had accessed calibration mode via Setup mode) or to the **Measurement mode** (if you had accessed calibration mode directly, pressing “CAL” key).



Note: When calibrating with manual temperature compensation, the controller automatically changes from the preset process temperature to the calibration temperature. After leaving the Calibration mode, the controller switches back to process temperature (for setting the calibration temperature and the process temperature, see Section 6.3)

5.4 View probe condition

The probe condition is an indication of its current working condition with respect to its original condition. The probe condition is calculated and stored in the controller each time calibration is done.

You can view probe condition without entering into calibration mode.

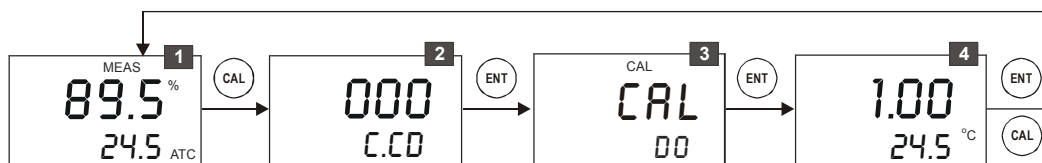

1. While in Measurement mode **press the CAL key**.
2. The display prompts you to enter the calibration security code (CCD). Leave the **security code at “000”** (view only mode). **Press the ENT key**.
3. The display shows “**CAL DO**”. **Press the ENT key**.
4. The display shows the actual probe condition. **Press the ENT key (or CAL key)** to return to the Measurement mode.



Note: If no key is pressed for 30 seconds during the above steps, the controller automatically returns to the Measurement mode.

6 SETUP MODE

6.1 Enter Setup mode

In the Setup mode the transmitter can be configured to your individual requirements.

1. While in Measurement mode **press the ENT key**.
2. The display prompts you to enter the security code. Set the security code with **▲ or ▼ key** to:
 - “SCD 22” if you want to change parameter settings
 - “SCD 000” if you want to view only parameter settings (**view only mode**)

Press the ENT key

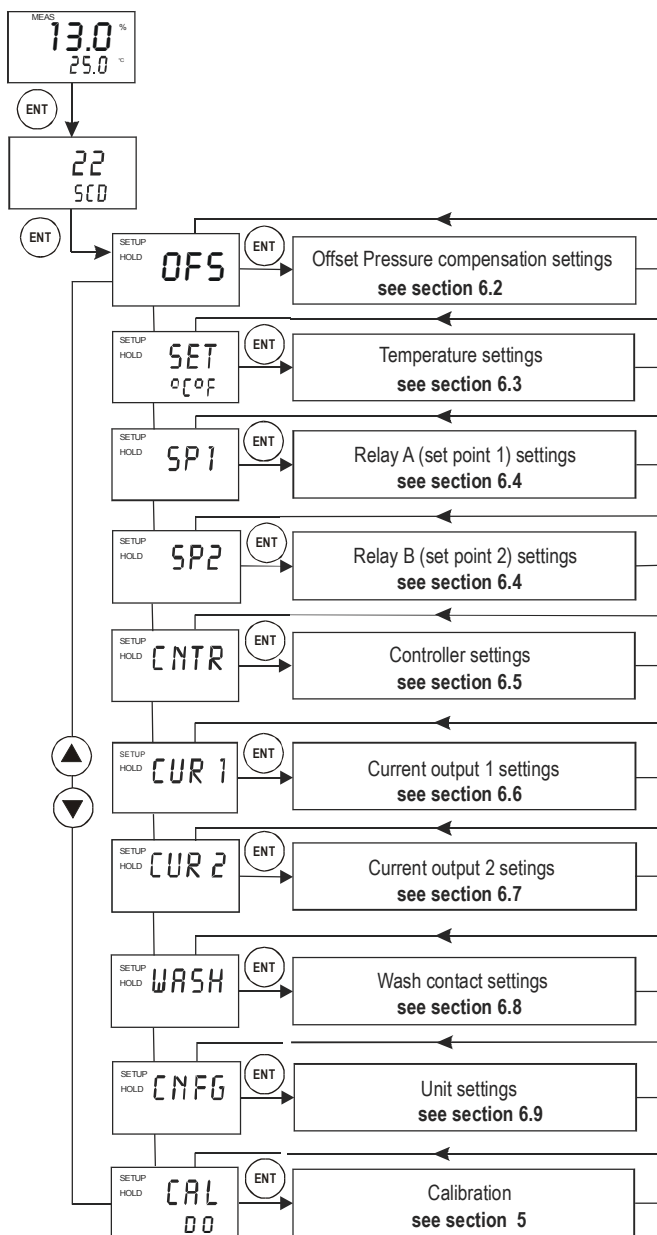

Note: To exit Setup mode at any time press the ▲ and ▼ key simultaneously (escape). The transmitter returns to the Measurement mode.

6.2 Offset, Salinity and Pressure compensation (OFS) sub-function

This mode allows you to change the offset parameter to make reading corrections without removing the electrode from the control system. You can make adjustments of up to ± 2.00 ppm; ± 2.00 mg/l; or $\pm 10.0\%$. At the end of the offset adjustment, the salinity value, followed by the pressure values (in mmHg or Pascal or PSI) respectively, is entered.

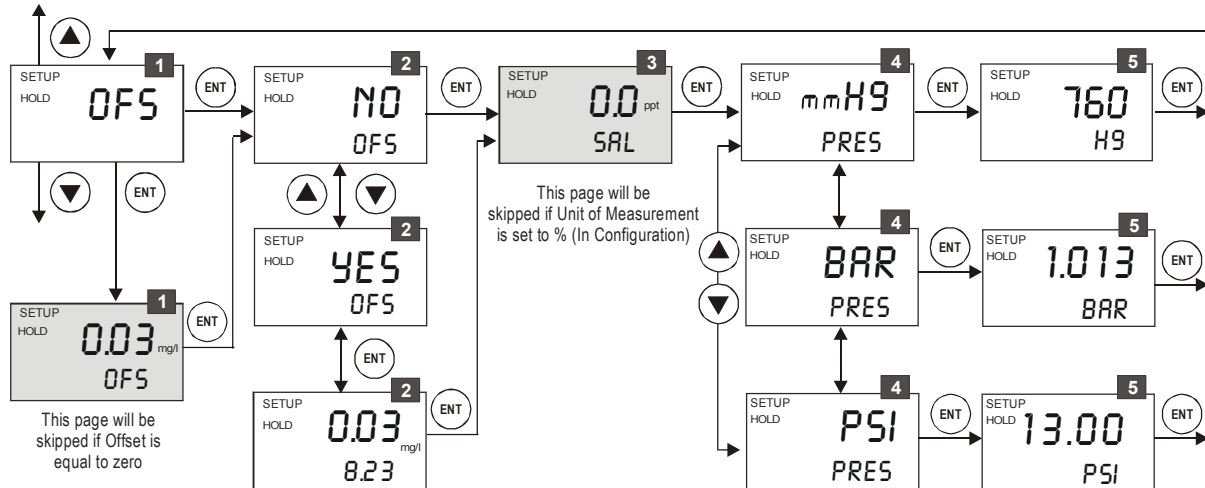

1. Select the “OFS” sub-function, and then **press the ENT key**.



Note: Controller displays the current offset value if there is a previously set offset value. **Press ENT key** to move to the next step. If the current offset is zero, then the controller does not show any value and automatically moves to the next step.

2. **Selecting to modify offset value:** By default, controller shows “NO OFS”. **Press the ▲ or ▼ key** to select “NO” or “YES” for offset adjustment.
 - Select “NO OFS” to skip offset adjustment and move to the next step.
 - Select “YES OFS” to perform offset adjustment.

Press the ENT key to confirm your selection.

- If “YES OFS” was selected:

Selecting offset value for the dissolved oxygen: The lower display shows the currently measured Dissolved Oxygen with its respective units. The upper display shows previously set offset value (if any); otherwise it shows “0.0”. **Press the ▲ or ▼ key** to set the required offset. **Press the ENT key** to confirm the offset value.



Note: The offset value is reset automatically during calibration (See section 5).

3. **Setting the Salinity Value:** The upper display shows the previously set salinity value in ppt, while the lower display shows “SAL”. **Press the ▲ or ▼ key** to adjust the salinity to desired value (between 0.0 ppt and 50.0 ppt: factory setting is 0.0 ppt) . **Press the ENT key** to confirm the Salinity value.



Note: This function is not available in the “%” mode and this window is not displayed.

4. **Setting the unit for pressure (PRES):** The upper display shows unit of measurement for pressure and the lower display shows "PRES". **Press the ▲ or ▼ key** to select the unit of measurement for pressure (mmHg or BAR or PSI). **Press the ENT key** to confirm the units.
5. **Setting the pressure value:** The upper display shows previously set pressure value (if any); otherwise it shows the default value. The lower display show the unit of measurement selected. **Use the ▲ or ▼ keys** to set the correct pressure. **Press the ENT key** to confirm the pressure value.

The controller goes back to "OFS" sub-function.

Continue with rest of the Setup procedures by pressing ▲ or ▼ key or return to the Measurement mode by pressing the ▲ and ▼ key (escape) simultaneously.

6.3 Setting temperature (Set °C°F) sub-function

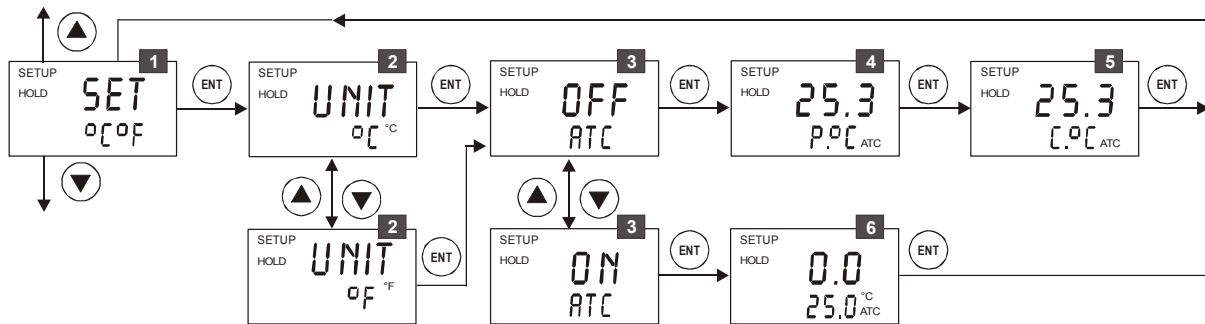

1. Select the “SET °C°F” sub-function and then **press the ENT key**.
2. **Selecting temperature unit:** Press the **▲** or **▼** key to select the desired temperature unit “°C” or “°F”. Press the **ENTER** key to confirm your selection.
3. **Enable/disable ATC mode:** Press the **▲** or **▼** key to enable (ATC ON) or disable (ATC OFF) automatic temperature compensation. Press the **ENT** key to confirm your selection.

– **ATC disabled (ATC OFF):**

For manual temperature compensation you can set the process and calibration temperatures. This allows calibration at a temperature other than the process temperature. Example: setting a calibration temperature of 25°C lets you calibrate using standard solutions at 25°C, even if your process temperature is different from 25°C.

4. **Setting the process temperature:** Press the **▲** or **▼** key to adjust the process temperature in the upper display value (setting range: –10.0 to 125.0°C / 14.0 to 257.0 °F). Press the **ENT** key to confirm process temperature.
5. **Setting the calibration temperature:** press the **▲** or **▼** key to adjust the calibration temperature in the upper display value (setting range: – 10.0 to 125.0°C / 14.0 to 257.0 °F). Press the **ENT** key to confirm the calibration temperature.

– **ATC enabled (ATC ON):**

6. **Setting the temperature offset:** The display shows the current temperature offset (upper display value) and the temperature currently measured (lower display value). Compare the current temperature displayed on the transmitter to a thermometer known to be accurate. Note the correct temperature value. Press the **▲** or **▼** key to adjust the lower display value. The upper number is automatically adjusted to the offset value. You can offset the temperature by up to $\pm 10^{\circ}\text{C}/\pm 18^{\circ}\text{F}$. Press the **ENT** key to confirm your setting.

The controller goes back to “SET °C°F” sub-function.

Continue with rest of the Setup procedures by pressing **▲** or **▼** key or return to the Measurement mode by pressing the **▲** and **▼** key (escape) simultaneously.

6.4 Control Relay A / Relay B (SP1/SP2) sub-function

The SP1 sub-function determines the operating parameters for Relay A; while SP2 defines the operating parameters for Relay B. Since these two sub functions have the same set-up parameters, only SP1 is described here.

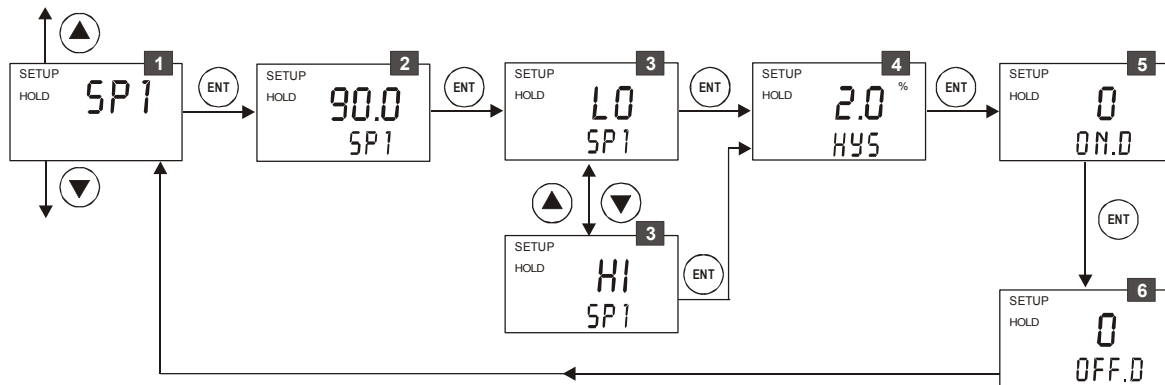

1. Select the “SP1” (Relay A) sub-function, then **press the ENT key**.
2. **Setting set point value:** Press the ▲ or ▼ key to enter the value for set point 1 at which your controller will activate. **Press the ENT key** to confirm your setting.
3. **Selecting relay function:** Press the ▲ or ▼ key to select the desired relay function (“LO”= low or “HI”= high). **Press the ENT key** to confirm your selection.



Note: This parameter lets you choose the relay function. Select “LO” to activate the relay when the dissolved oxygen value undershoots the set point; select “HI” to activate the relay when the value overshoots the set point. SP1 and SP2 can be selected as “Lo/Lo”, “Lo/Hi”, “Hi/Lo”, or “Hi/Hi”.

4. **Setting a hysteresis value:** Press the ▲ or ▼ key to select the desired hysteresis (setting range: 1 to 10% or 0.1 to 1.0 mg/l) for set point 1. **Press the ENT key** to confirm your setting.



Note: Hysteresis prevents rapid contact switching if your value is fluctuating near the set point. Please refer to Appendix 3 for a graphical representation of the hysteresis.

Example: You have set your high set point at 90 % and your hysteresis value is 2 %. If your measured value overshoots 90 %, the controller’s relay activates. The actions of the external device will cause the solution’s dissolved oxygen percentage saturation to drop. The relay will deactivate, when the dissolved oxygen percentage saturation value drops below 88 %.

5. **Setting the on-delay time lag:** Press the ▲ or ▼ key to enter the on-delay time for set point 1 (set point 2). The controller will delay activation of the relay for the number of seconds (0 to 2000 seconds) you select. **Press the ENT key** to confirm your setting.



Note: You can set a time delay for each relay, which stops the relay from switching on the moment the set point is exceeded. This controller lets you set a 0 to 2000 seconds time delay before your relay activates.

6. **Setting the off-delay time lag:** press the ▲ or ▼ key to enter the off-delay time for set point 1 (set point 2). Your controller will delay deactivation of the relay for the number of seconds (0 to 2000 seconds) you select. **Press the ENT key** to confirm your setting.



Note: You can set a time delay for each relay, which stops the relay from switching off the moment the value reaches the set point and hysteresis. This controller lets you set a 0 to 2000 seconds time delay before your relay deactivates.

The controller goes back to “SP1” sub-function.

Continue with rest of the Setup procedures by pressing ▲ or ▼ key or return to the Measurement mode by pressing the ▲ and ▼ key (escape) simultaneously.

6.5 Controller (CNTR) sub-function

The CNTR sub-function determines the controller's parameters.

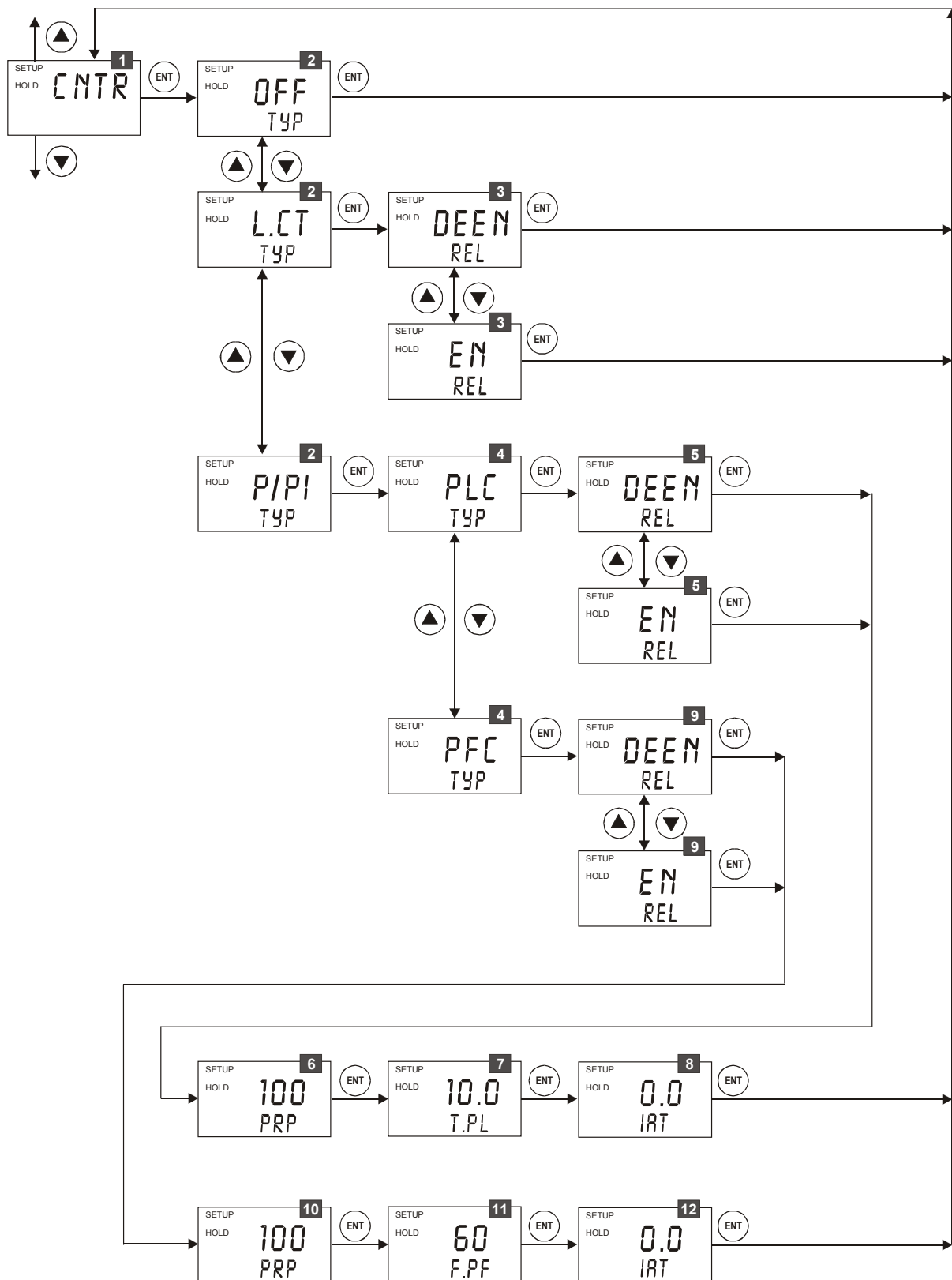

1. Select the "CNTR" sub-function and then **press the ENT key**.
2. **Selecting the controller type (TYP): Press the ▲ or ▼ key** to select the suitable controller type:
 - OFF = controller off
Use control Off to operate controller as a monitor only or to prevent relays from switching. When the controller is set to OFF, all the LEDs will be switch off in the Measurement mode
 - L.CT = limit value control (on/off control).
Use limit control with pumps or valves for fast response
 - P/PI = proportional/integral control
Use proportional control to operate your pumps smoothly or for precise control of proportioning valves. Use PI controller to eliminate steady state error.



Note: please refer to Appendix 4 for detailed information on controller settings.

Press the ENT key to confirm your selection.

- If the controller is set to **limit value control (L.CT)**:
3. **Selecting the relay status under Non-Alarm condition (REL): Press the ▲ or ▼ key** to choose the desired relay status (de-energized = "DEEN" or energized = "EN"). Press the ENT key to confirm your selection.
 - If the controller is set to **proportional control (P/PI)**:
 4. **Selecting the proportional controller type (TYP): Press the ▲ or ▼ key** to select the suitable controller type ("PLC" = pulse length control, "PFC" = pulse frequency control). **Press the ENT key** to confirm your selection.
 - If the proportional controller type is set to **pulse length control (PLC)**:
 5. **Selecting the relay status under Non-Alarm condition (REL): Press the ▲ or ▼ key** to choose the desired relay status (de-energized = "DEEN" or energized = "EN"). **Press the ENT key** to confirm your selection.
 6. **Setting the proportional range (PRP): Press the ▲ or ▼ key** to set the proportional range (setting range: 10 to 500%). **Press the ENT key** to confirm your setting.
 7. **Setting the pulse length (T.PL): Press the ▲ or ▼ key** to set the pulse length (setting range: 0.5 to 20 seconds). **Press the ENT key** to confirm your setting.
 8. **Setting the integral action time (IAT): Press the ▲ or ▼ key** to set the integral action time (setting range: 0.0 to 999.9 minutes). **Press the ENT key** to confirm your setting.

- If the proportional controller type is set to **pulse frequency control (PFC)**:
9. **Selecting the relay status under Non-Alarm condition (REL):** Press the **▲** or **▼** key to choose the desired relay status (de-energized = “DEEN” or energized = “EN”). Press the **ENT** key to confirm your selection.
 10. **Setting the proportional range (PRP):** Press the **▲** or **▼** key to set the proportional range (setting range: 10 to 500%). Press the **ENT** key to confirm your setting.
 11. **Setting the pulse frequency (F.PF):** Press the **▲** or **▼** key to set the pulse frequency (setting range: 60 to 120 pulses per minute). Press the **ENT** key to confirm your setting.
 12. **Setting the integral action time (IAT):** Press the **▲** or **▼** key to set the integral action time (setting range: 0.0 to 999.9 minutes). Press the **ENT** key to confirm your setting.

The controller goes back to “CNTR” sub-function.

Continue with rest of the Setup procedures by pressing **▲** or **▼** key or return to the Measurement mode by pressing the **▲** and **▼** key (escape) simultaneously.

6.6 Current Output 1 (CUR 1) sub-function

In this sub-function you set the current output range of the transmitter for dissolved oxygen values.

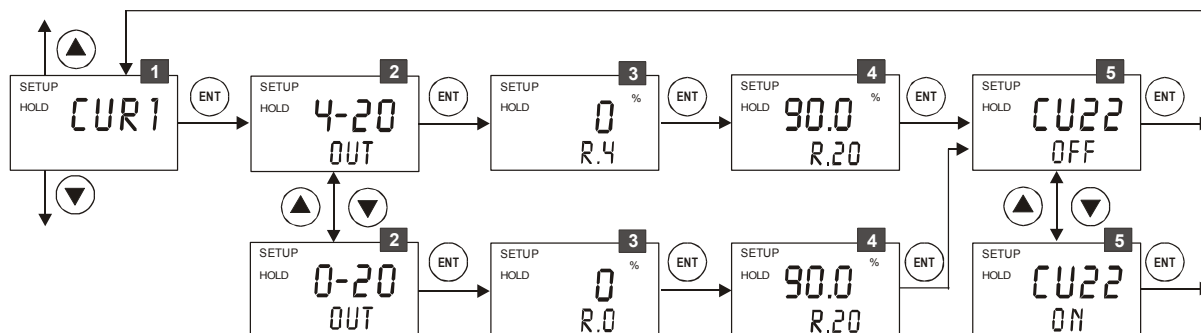

1. Select the “CUR 1” sub-function and then **press the ENT key**.
2. **Selecting the output type:** Press the **▲** or **▼** key to select the desired output type: 0-20 mA or 4-20 mA. Press the **ENT** key to confirm your selection.
3. **Setting the dissolved oxygen value at which the transmitter output will be 4 mA (or 0 mA):** Press the **▲** or **▼** key to set the dissolved oxygen value to be equivalent to 4 mA or 0 mA, respectively. Press the **ENT** key to confirm your setting.
4. **Setting the dissolved oxygen value at which the transmitter output will be 20 mA:** Press the **▲** or **▼** key to set the dissolved oxygen value to be equivalent to 20 mA. Press the **ENT** key to confirm your setting.
5. **Selecting out of range current:** Press the **▲** or **▼** key to switch “CU22” on or off. If “CU22” is on, the output signal will jump to 22 mA when the measured dissolved oxygen value is below or above the values set in points 3 & 4 above. Press the **ENT** key to confirm your setting.



Note: the “CU22” setting (on/off) of current output 1 applies to current output 2 as well.

The controller goes back to “CUR 1” sub-function.

Continue with rest of the Setup procedures by pressing **▲** or **▼** key or return to the Measurement mode by pressing the **▲** and **▼** key (escape) simultaneously.

6.7 Current Output 2 (CUR 2) sub-function

In this sub-function you set the current output range of the transmitter for temperature values.

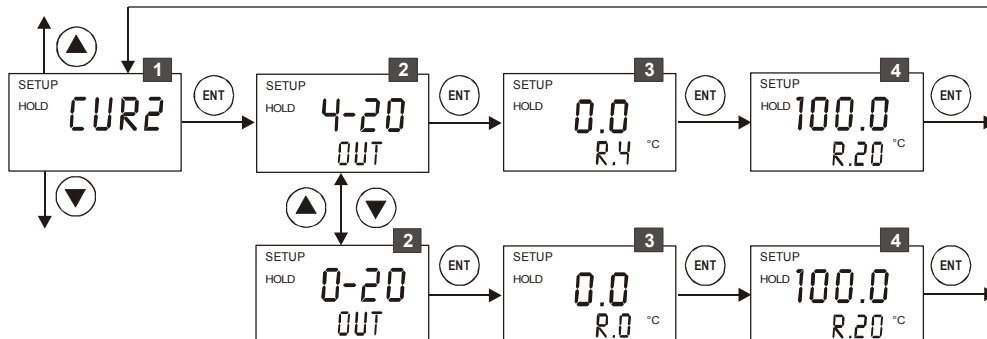

1. Select the "CUR 2" sub-function and then **press the ENT key**.
2. **Selecting the output type: Press the ▲ or ▼ key** to select the desired output type: 0-20 mA or 4-20 mA. **Press the ENT key** to confirm your selection.
3. **Setting the temperature value at which the transmitter output will be 4 mA (or 0 mA): Press the ▲ or ▼ key** to set the temperature value (setting range: -10.0 to 115.0 °C or 14 to 237 °F) to be equivalent to 4 mA (or 0 mA). **Press the ENT key** to confirm your setting.
4. **Setting the temperature value at which the transmitter output will be 20 mA: Press the ▲ or ▼ key** to set the temperature value (setting range: 0.0 to 125.0 °C or 32 to 257 °F) to be equivalent to 20 mA. **Press the ENT key** to confirm your setting.

The controller goes back to "CUR 2" sub-function.

Continue with rest of the Setup procedures by pressing ▲ or ▼ key or return to the Measurement mode by pressing the ▲ and ▼ key (escape) simultaneously.

6.8 Wash relay (WASH) sub-function

In this sub-function you set the parameters for the wash relay.

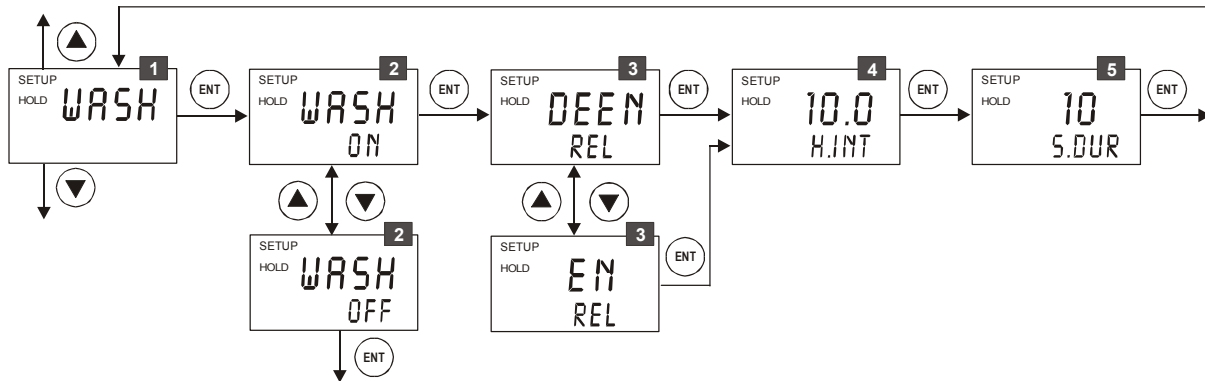

1. Select the “WASH” sub-function and then **press the ENT key**.
2. **Enabling/disabling wash function: Press the ▲ or ▼ key** to enable (WASH ON) or disable (WASH OFF) wash function. **Press the ENT key** to confirm your selection.
 - If “WASH OFF” was selected, the transmitter returns “WASH” sub-function.
 - If “WASH ON was selected:
 3. **Selecting the relay status condition: press the ▲ or ▼ key** to choose desired relay status (de-energized = “DEEN” or energized = “EN”). **Press the ENT key** to confirm your selection.
 4. **Setting the wash interval in hours: Press the ▲ or ▼ key** to set the desired wash interval (setting range: 0.1 to 200.0 hours). **Press the ENT key** to confirm your setting.
 5. **Setting the wash duration in seconds: Press the ▲ or ▼ key** to set the desired wash duration (setting range: 1 to 2000 seconds). **Press the ENT key** to confirm your setting.



Note: During wash cycle the transmitter is set to HOLD. For safety reasons, the HOLD function is activated 5 seconds prior and deactivated 10 seconds after the wash cycle.

The controller goes back to “WASH” sub-function.

Continue with rest of the Setup procedures by pressing ▲ or ▼ key or return to the Measurement mode by pressing the ▲ and ▼ key (escape) simultaneously.

6.9 Configuration (CNFG) sub-function

In this sub-function you configure the transmitter to suit your requirements.

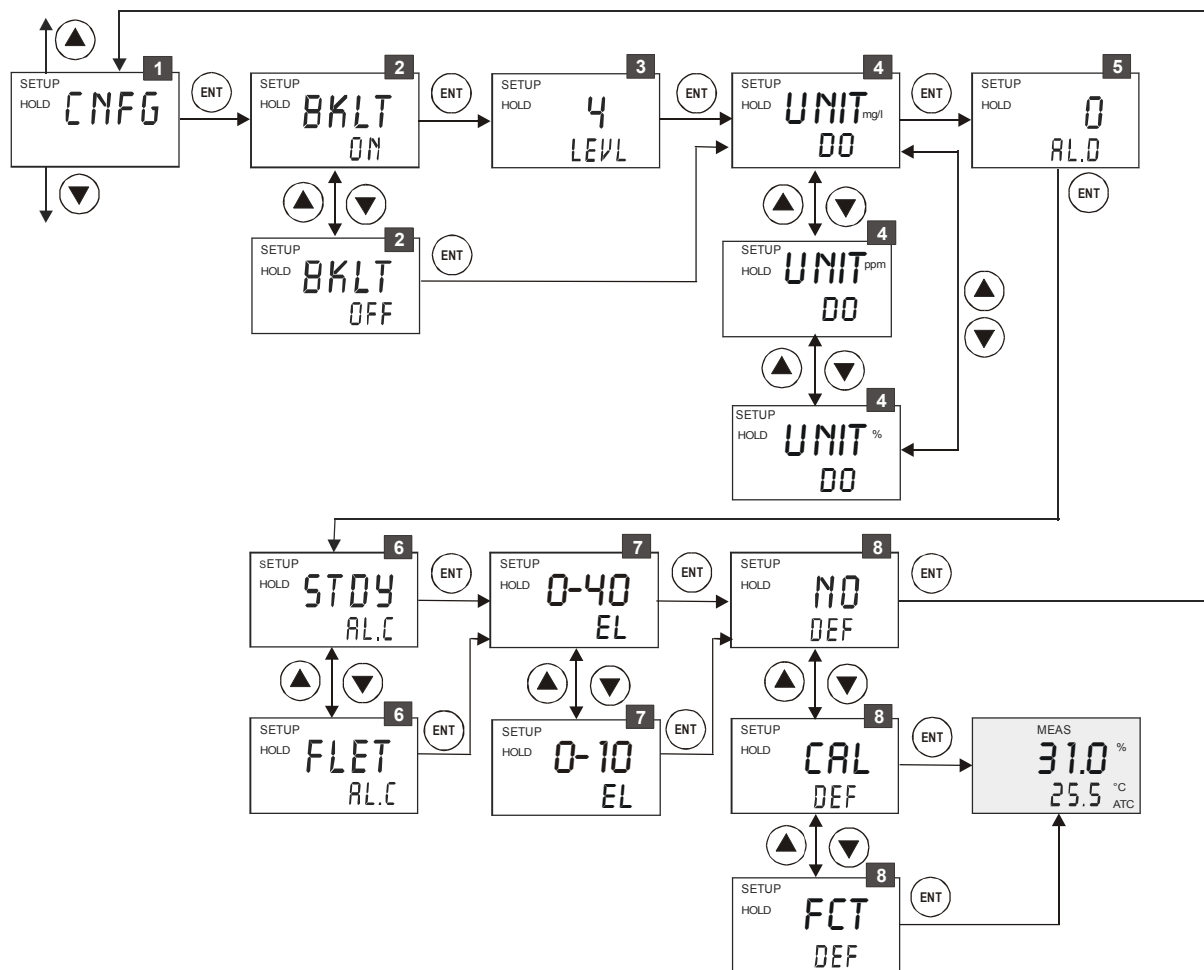

1. Select the “CNFG” sub-function and then **press the ENT key**.
2. **Enabling/disabling the display backlight:** Press the **▲** or **▼** key to switch display backlight on (BKLT ON) or off (BKLT OFF). **Press the ENT key** to confirm your selection.
3. **Setting the backlight intensity** (appears only If backlight is on): **Press the ▲** or **▼** key to set backlight intensity (setting range: minimum 1 to maximum 4). **Press the ENT key** to confirm your setting.
4. **Selecting the unit of measurement:** Press the **▲** or **▼** key to select “mg/l” or “ppm” or “%” type. **Press the ENT key** to confirm your selection.
5. **Setting the alarm delay time in seconds:** Press the **▲** or **▼** key to set the alarm delay time (setting range: 0 to 2000 seconds). **Press the ENT key** to confirm your setting.



Note: With this parameter you set the delay before the alarm relay activates when the set point has been exceeded.

6. **Selecting the alarm contact type:** Press the ▲ or ▼ key to select the alarm contact type:

- “STDY” = steady contact
- “FLET” = fleeting (single pulse) contact

Press the ENT key to confirm your selection.



Note: With this parameter you select whether the alarm contact will operate as a steady contact or a fleeting (single pulse) contact. Pulse contact closing time is 1 second.

7. **Selecting the electrode type:** The upper display shows “0-10” or “0-40” and lower display shows “EL”. Press the ▲ or ▼ key to select the electrode type:

- “0-10” = 0 to 10 ppm measurement range (low range probe)
- “0-40” = 0.5 to 40 ppm measurement range (high range probe)
- “ELEC” = Electrode or Probe



Note: After each changeover, the factory calibration data for zero point and slope are overwritten. Be sure to recalibrate (see section 5).

8. **Resetting the transmitter settings to factory defaults:** The display shows “NO DEF”. Press the ▲ or ▼ key to select:

- “NO DEF” = keeps user configured values active, when confirmed with ENT key
- “FCT DEF” = resets all settings to factory defaults, when confirmed with ENT key
- “CAL DEF” = resets all calibration settings to factory defaults, when confirmed with ENT key

Press the ENT key to confirm your selection.

- If “NO DEF” was selected, the transmitter returns “CNFG” sub-function.

Continue with rest of the Setup procedures by pressing ▲ or ▼ key, or return to Measurement mode by pressing the ▲ and ▼ keys (escape) simultaneously.

- If “FCT DEF” or “CAL DEF” was selected, the selected function will be executed and the transmitter returns automatically to the Measurement mode.

6.10 **Calibration (CAL) sub-function**

The calibration procedure in Setup mode is identical to the procedure in the Calibration mode (see section 5). The only difference is that the transmitter remains in Setup mode (instead of Measurement mode) after calibration is completed.

7 RELAY MODES

You can control devices connected to Relay A, Relay B or wash relay via the front panel of the transmitter. In Automatic mode, the transmitter's set point values activate the relays. In Manual mode, you can manually turn "on" and "off" the control devices connected to the relays.

7.1 View relay set points

To view relay set points, the relay mode must be set to automatic (standard mode after switch-on, relay mode LED "Auto" lights).

While in Measurement mode, press the REL key.

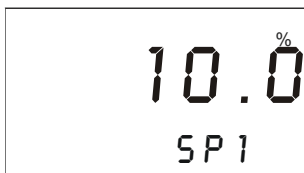

The display shows the relay set point value for Relay A and LED "A" lights. (The mode of the relay set point will be with respect to the measurement mode before REL key is pressed).



After two seconds the display shows the set point value for Relay B and LED "B" lights).



After two seconds the display shows the status of the Wash relay and LED "W" lights. If Wash relay is "off" the display shows "WASH OFF". If Wash relay is "on" the wash interval time and wash duration is displayed.

After an additional two seconds the transmitter will return to Measurement mode.

7.2 Manual relay mode

In manual relay mode, you can manually turn “on” and “off” the control devices connected to Relay A, Relay B or Wash relay.

1. While in Measurement mode **press the MODE key**.
2. The display prompts you to enter the security code. **Press the ▲ or ▼ key** to set security code to “22”.
3. **Press the ENT key**. The Manual relay mode is activated and the relay mode LED “Manu” lights.



Note: Pressing ENT key at a value other than “22” will cause the transmitter to revert to Measurement mode, and the relays will remain in automatic mode.

4. Press the REL key to select either Relay A, Relay B or Wash relay. The corresponding LED (A, B, or W) turns to red.

The manual control options now available depend on the control type (limit, pulse frequency, or pulse length) you selected and set in section 6.5.

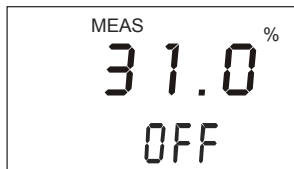

If you selected Limit control: The display shows the current measured value and “OFF” or “ON” depending on the relay status of the currently selected relay.

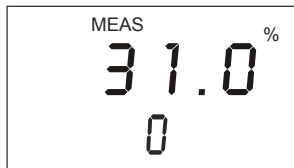

If you selected Pulse length control: The display shows the current measured value (upper display value) and the on time as a percentage of the current duration set in the CNTR sub-function in setup mode (lower display value).



If you selected Pulse frequency control: The display shows the current measured value (upper display value) and the pulse frequency (lower display value).

Press the ▲ or ▼ key to change the Relay on/off status, pulse length, pulse frequency or wash function. The relay status LED at the right of the transmitter will also change from Red to Green.



Note: Note: If you wish to manually change the status of relays, press the **REL key** at this point and repeat step 5 for the other two relays. The relay(s) will remain under manual control while you are setting a relay.

Press the MODE key to return to Measurement mode. The relays go back to automatic control.

8 TECHNICAL SPECIFICATIONS

8.1 Measurement and Compensation	
(a) Dissolved Oxygen	
Dissolved Oxygen Measuring Range	0.00 to 25.00 mg/l or 0.00 to 25.00ppm or 00.0 to 300.0 % Saturation
Resolution	0.01 mg/l or 0.01 ppm or 0.1 %
Relative accuracy	1.5 % of full-scale reading for all ranges
(b) Temperature	
Temperature measuring range	-10.0 to +125.0 °C or +14.0 to +257.0 °F
Resolution	0.1 °C or 0.1 °F
Relative accuracy	0.5 °C or 1.0 °F
Sensor	Pt100 or Pt1000 (Jumper Selectable) – 2 wire or 3 wire
(c) Compensation	
Temperature Compensation	Automatic or Manual
Pressure Compensation	0.740 to 3.000 BAR or 555 to 2250 mmHg or 10.73 to 43.51 PSI (Manual setting and automatic correction)
Salinity Compensation	0.0 to 50.0 ppt (Manual setting and automatic correction)

8.2 Set-point and control function – Relay 1 & Relay 2	
Function Switchable - Selection in Control (CNTR) function of Setup	Off Limit Control P/PI Control (Pulse length / Pulse frequency)
(a) Off	
The control function of the controller is off	SP1 & SP2 function will not appear in setup when Off is selected in CNTR function to off mode
(b) Limit Control & P/PI Control	
Relay contact selection for active mode	Energise (EN) or De-energise (DEEN)
Set Point 1 (SP1)	0.0 to 300.0 % (0.00 to 25.00 mg/l) (0.00 to 25.00 ppm)
Set Point 2 (SP2)	0.0 to 300.0 % (0.00 to 25.00 mg/l) (0.00 to 25.00 ppm)
Active mode selection (for SP1 & SP2)	LO (Relay is active when measured value < set point) HI (Relay is active when measured value > set point)
Hysteresis (for SP1 & SP2)	1.0 to 10.0 %
On (pickup) Delay (for SP1 & SP2)	0 to 2000 seconds
Off (Dropout) Delay (for SP1 & SP2)	0 to 2000 seconds

(c) P/PI Control only	
Proportional Range	10 to 500 %
Integral Action Time (IAT)	0.0 to 999.9 minutes
(c) (1) Pulse Length Control (PLC)	
Pulse Length	0.5 to 20.0 seconds
(c) (2) Pulse Frequency Control (PFC)	
Pulse Frequency	60 to 120 pulses / minutes
Contact Outputs	Two SPST relays
Switching Voltage / Current / Power	Max 250VAC / Max 3A / Max 600VA

8.3 Wash Function – Wash Relay	
Relay contact selection for active mode	Energise (EN) or De-energise (DEEN)
Wash Cycle Interval	0.1 to 200.0 hours
Wash Duration	1 to 2000 seconds
Contact Outputs	One SPST relay
Switching Voltage / Current / Power	Max 250VAC / Max 3A / Max 600VA

8.4 Alarm Function – Alarm Relay	
Alarm Delay	0 to 2000 seconds
Alarm control	Steady or fleet (pulse)
Contact Outputs	One SPDT relay
Switching Voltage / Current / Power	Max 250VAC / Max 3A / Max 600VA

8.5 Transmitter Function	
(a) Current Output 1 - DO	Proportional to Dissolved Oxygen measured
Current output selection	4 – 20mA or 0 – 20mA
DO value for 0 or 4mA current	0 to 25 mg/l or 0 to 300 %
DO value for 20mA current	0 to 25 mg/l or 0 to 300 %
CU22 function	<p>On</p> <ul style="list-style-type: none"> - 22mA current output for over range or under range or if outside zoom setting <p>Off</p> <ul style="list-style-type: none"> - 0 or 4 mA current output for under range or below lower zoom setting - 20mA current output for over range or above upper zoom setting
(b) Current Output 2 - Temperature	Proportional to Temperature measured
Current output selection	4 – 20mA or 0 – 20mA
Temperature value for 0 or 4mA current	-10.0 to +125.0 °C or +14.0 to +257.0 °F
Temperature value for 20mA current	-10.0 to +125.0 °C or +14.0 to +257.0 °F

8.6 Voltage Output & Hold Function Switch	
+12 V Output	11.5 to 12.5 V Output – Max 50 mA
Hold Function Switch	Hold function to freeze output current (0/4...20mA) and release control relays

8.7 Display	
LCD	UV coat, backlit 14 segments display with symbols for status information
Back light	On/Off selectable with four levels of brightness control

8.8 Power Supply	
Input	80 to 250VAC/DC, 50/60Hz, Approximately 10VA
Main Fuse	315mA Anti-surge, 250V
Pollution Degree	2
Transient Voltage Category	II
Connector	5-pin screw terminal

8.9 Electrical data and Connections	
Dissolved Oxygen Input	8-pin Screw Terminal (3.5mm pitch)
Temperature Input	8-pin Screw Terminal (3.5mm pitch)
Relay 1, Relay 2, Wash Relay & Alarm Relay	9-pin Screw Terminal (7.62mm pitch)
Current Output 1, Current Output 2, 12V output & Hold function switch	13-pin Screw Terminal (3.5mm pitch)
Connection terminal	5-pin, 8-pin, 9-pin & 13-pin terminal connectors

8.10 Mechanical Specifications	
Dimensions (W x H x D) - Wall Mount	144 x 144 x 111.5 mm
Weight - Wall Mount	950g (unit) / 1100g (Packed)
Environmental Rating - Wall Mount	NEMA 4X, IP66

8.11 Electromagnetic Compliance (EMC) Specifications	
Emitted Interference	EN 61326
Immunity to Interference	EN 61326

8.12 Environmental Conditions	
Ambient Temperature operating range	0 to 40 °C
Maximum Relative Humidity	80% up to 31 °C decreasing linearly to 50% at 40°C

9 ACCESSORIES

9.1 Replacement Unit

Product Description	Eutech Instruments Order Code
αalpha DO 2000 Controller / Transmitter, wall mount version	EC-DOCTP2000W

9.2 Assembly Accessories

Product Description	Eutech Instruments Order Code
General Purpose Dissolved Oxygen Probe 0.5-40PPM with integrated Pt 100 and 5M cable (open-ended)	ECDOGEN
Low Oxygen Dissolved Oxygen Probe 0-10PPM with integrated Pt 100 and 5M cable (open-ended)	EC-DOTYP II
Panel Mount Kit for αalpha 2000	01X278701



Note: Above Dissolved Oxygen probes can withstand a pressure up to 10 bar and operate from 0 to 40 °C. Please ask your authorized distributor or dealer for the prices.

Note: Please contact your authorised distributor or dealer for the prices of extension measuring cables and other accessories like tee joints, electrode assembly, and calibration solutions.

10 GENERAL INFORMATION

10.1 Warranty

Eutech Instruments warrants this product to be free from significant deviations in material and workmanship for a period of one year from the date of purchase. If repair is necessary and not the result of abuse or misuse within the warranty period, please return by freight pre-paid and amendment will be made without any charge. Eutech Instrument Customer Service Dept. will determine if the product problem is due to deviations or customer abuse. Out-of-warranty products will be repaired on an exchange basis at cost.

10.2 Packaging / Scope of delivery

The instrument is packaged in a corrugated box with an instruction manual and the following accessories:

Wall mount version:

- Plug, nylon, red, 2 pcs
- PG13.5, cable gland, 3 pcs
- Connectors, one each of 5 way (5.08 mm), 9 way (7.62 mm), 13 way (3.5mm), 8 way (3.5mm)

10.3 Return of goods

Before returning goods for any reason whatsoever, Customer Service Dept. has to be informed in advance. Items must be carefully packed to prevent damage during shipment, and insured against possible damage or loss. Eutech Instruments will not be responsible for any damage resulting from careless or insufficient packing.

Warning: Shipping damage as a result of inadequate packaging is the user's/distributor's responsibility, whoever applicable. Please follow the guidelines below before shipment.

10.4 Guidelines for returning unit for repair

Use the original packaging material if possible when shipping the unit for repair. Otherwise wrap it with bubble pack and use a corrugated box for better protection. Include a brief description of any faults suspected for the convenience of Customer Service Dept., if possible.

10.5 Maintenance and Cleaning

Maintenance

The alpha DO 2000 contains no user repairable components. Please contact Eutech Instruments or its distributor if there is any problem with the unit.

Cleaning

To remove dust, dirt and spots, the external surfaces of the transmitter may be wiped with a damp, lint-free cloth. A mild household cleaner can also be used if necessary.

11 APPENDICES

11.1 Appendix 1 – Unit fuse and jumper settings



Caution! Before opening the unit to replace the unit fuse or to set the jumper for Pt 100 / Pt 1000 temperature sensor, make sure the mains cable is separated from the power supply.

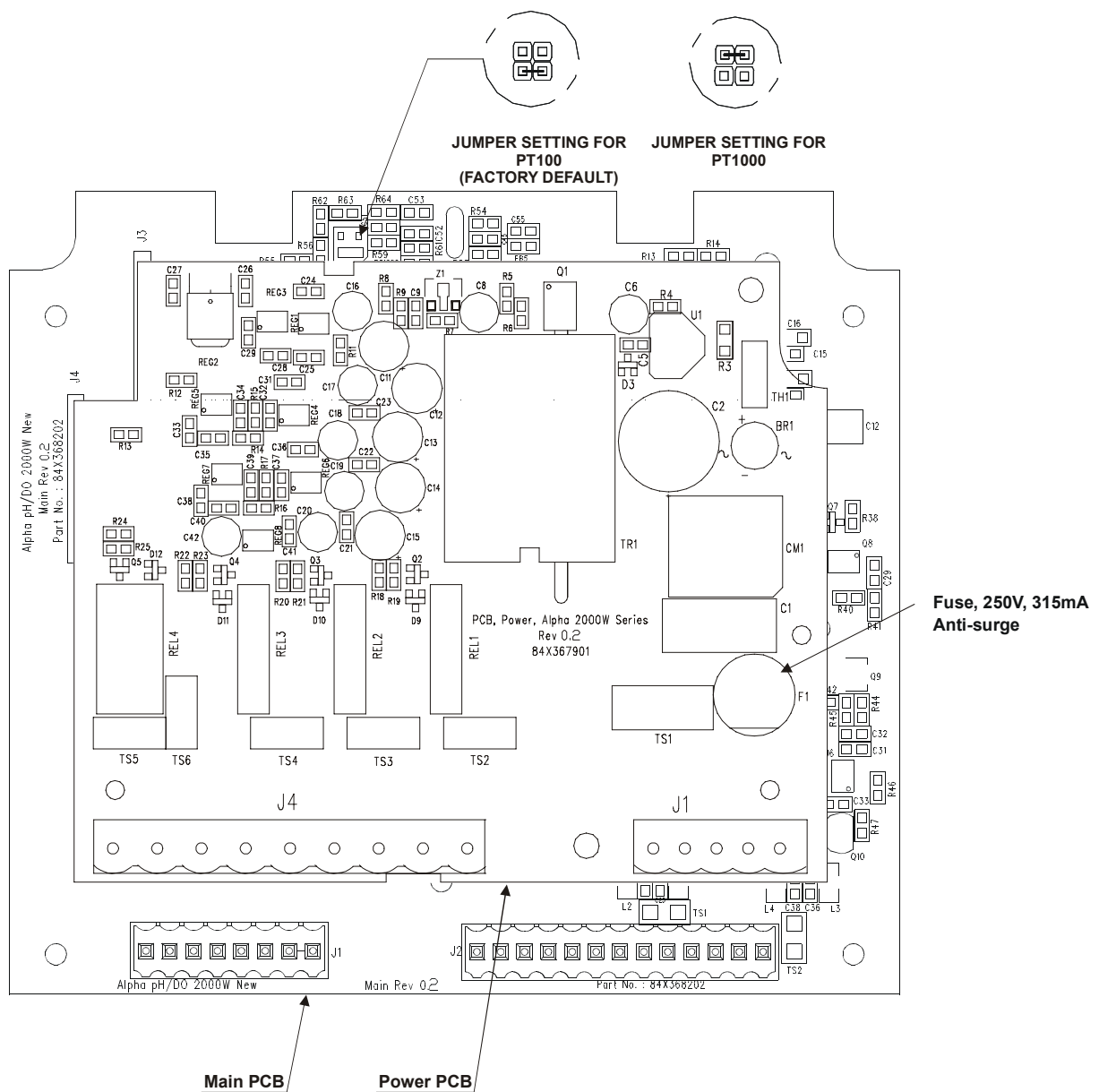

11.2 Appendix 2 – Salinity vs Temperature (@ 760 mmHg)

The following table shows the Dissolved Oxygen values at different salinity values, at different temperatures, at barometric pressure of 760 mmHg. For other pressure levels, the controller automatically corrects the value based on the pressure value input.

Temperature		Salinity- ppt				
°C	°F	0	10	20	30	40
0	32.0	14.6	13.8	13.0	12.1	11.3
1	33.8	14.2	13.4	12.6	11.8	11.0
2	35.6	13.8	13.1	12.3	11.5	10.8
3	37.4	13.4	12.7	12.0	11.2	10.5
4	39.2	13.1	12.4	11.7	11.0	10.3
5	41.0	12.7	12.1	11.4	10.7	10.0
6	42.8	12.8	11.8	11.1	10.5	9.8
7	44.6	12.1	11.5	10.9	10.2	9.6
8	46.4	11.8	11.2	10.6	10.0	9.4
9	48.2	11.5	11.0	10.4	9.8	9.2
10	50.0	11.3	10.7	10.1	9.6	9.0
11	51.8	11.0	10.5	9.9	9.4	8.8
12	53.6	10.7	10.3	9.7	9.2	8.6
13	55.4	10.5	10.1	9.5	9.0	8.5
14	57.2	10.3	9.9	9.3	8.8	8.3
15	59.0	10.1	9.7	9.1	8.6	8.1
16	60.8	9.8	9.5	9.0	8.5	8.0
17	62.6	9.6	9.3	8.8	8.3	7.8
18	64.4	9.4	9.1	8.6	8.2	7.7
19	66.2	9.2	8.8	8.5	8.0	7.6
20	68.0	9.1	8.7	8.3	7.8	7.4
21	69.8	8.9	8.6	8.1	7.7	7.3
22	71.6	8.7	8.4	8.0	7.6	7.1
23	73.4	8.6	8.3	7.9	7.4	7.0
24	75.2	8.4	8.1	7.7	7.3	6.9
25	77.0	8.2	8.0	7.6	7.2	6.7
26	78.8	8.1	7.8	7.4	7.0	6.6
27	80.6	8.0	7.7	7.3	6.9	6.5
28	82.4	7.8	7.6	7.1	6.8	6.4
29	84.2	7.7	7.4	7.0	6.6	6.3
30	86.0	7.6	7.3	6.9	6.5	6.1
31	87.8	7.4	7.1	6.7	6.4	6.0
32	89.6	7.3	7.0	6.6	6.3	5.9
33	91.4	7.2	6.9	6.5	6.2	5.8
34	93.2	7.1	6.8	6.5	6.1	5.7
35	95.0	7.0	6.7	6.4	6.0	5.6
36	96.8	6.8	6.5	6.2	5.9	5.5
37	98.6	6.7	6.4	6.1	5.8	5.4
38	100.4	6.6	6.3	6.0	5.7	5.3
39	102.2	6.5	6.3	5.9	5.6	5.2
40	104.0	6.4	6.3	5.8	5.5	5.2

11.3 Appendix 3 – Simple explanation on the function of hysteresis

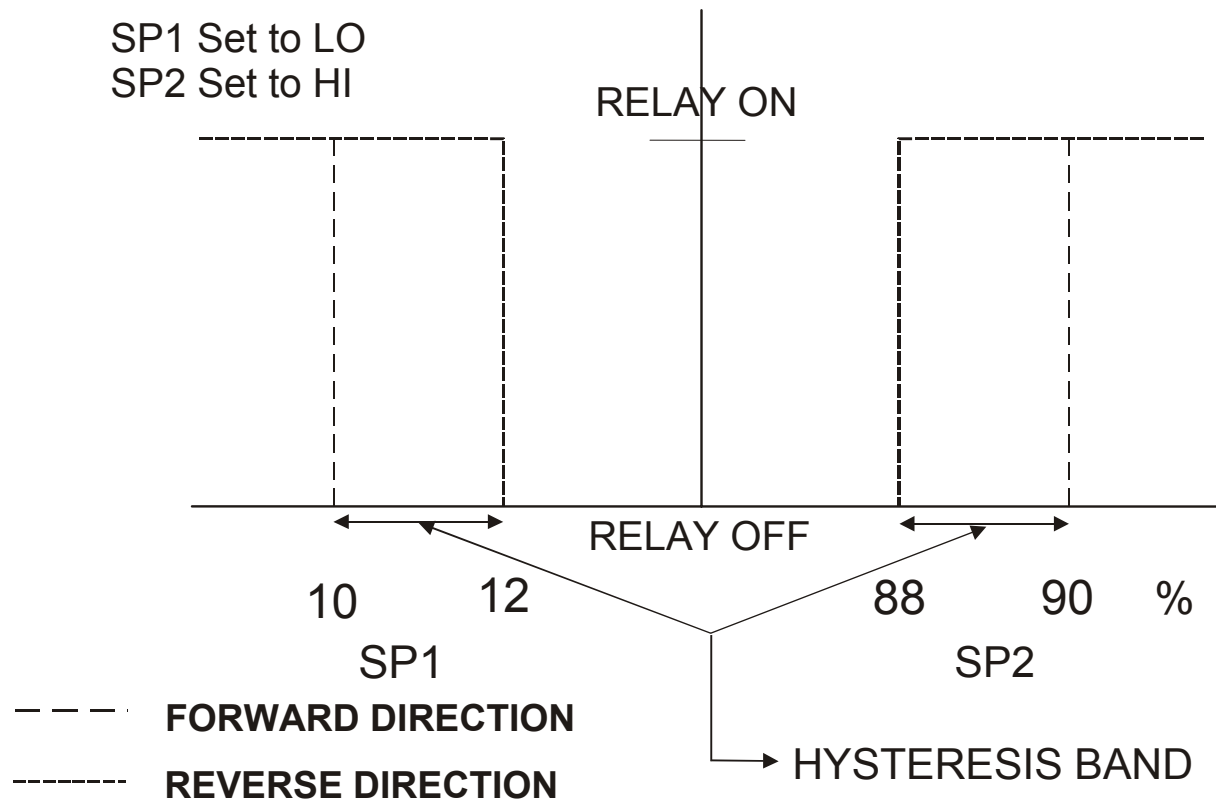

The controller relay activates when the set-point is reached. In the reverse direction, it does not de-activate when the value reaches the set-point. Instead, it continues to be active till the value reaches the amount set by the Hysteresis band.

11.4 Appendix 4 – General instructions concerning Controller Setting

11.4.1 *Control characteristic of Controllers used as limit value switch*

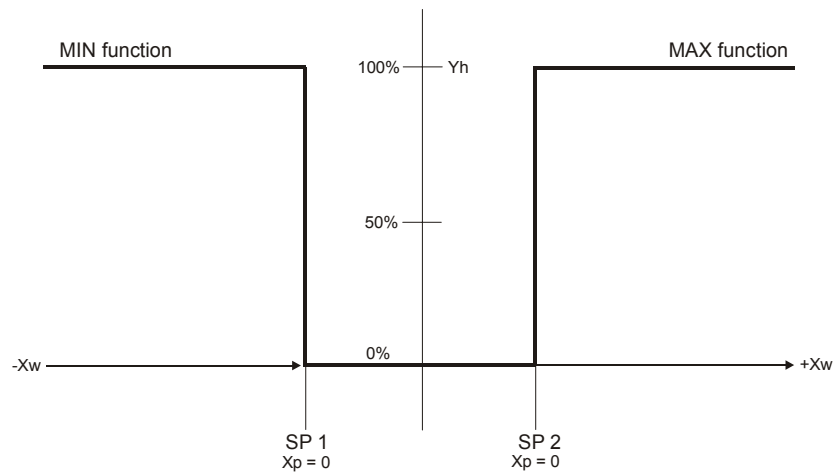

11.4.2 *Control characteristic of P-Controllers as proportional controller*

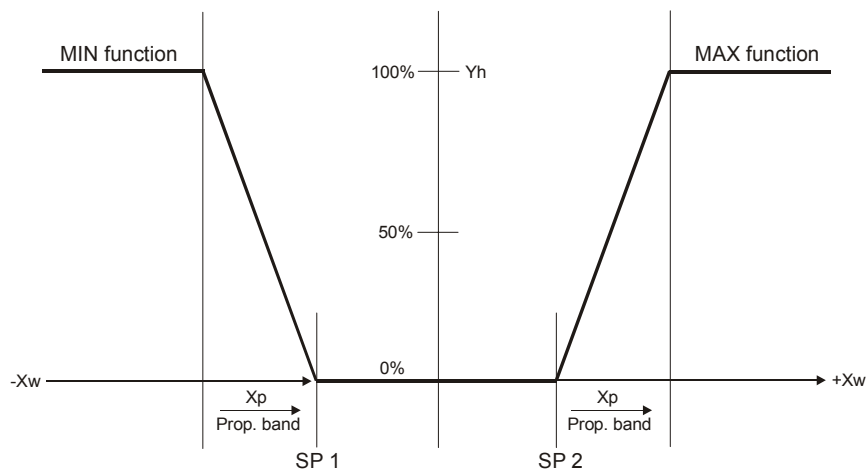

11.4.3 *Control characteristic of PI-Controllers as proportional integral controller*

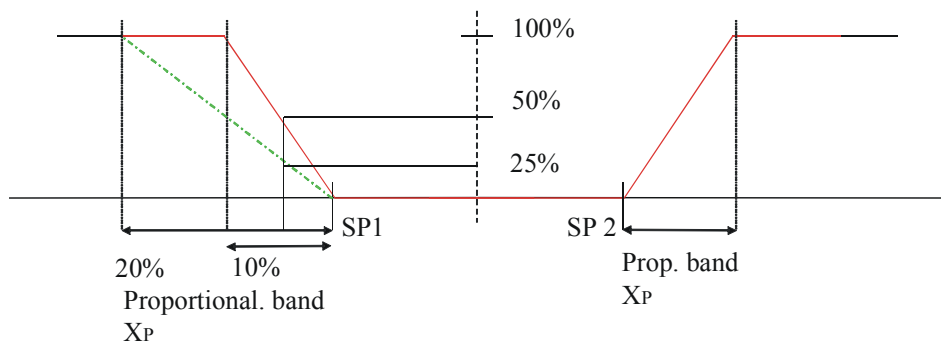

11.4.4 Control signal of Pulse length Controllers

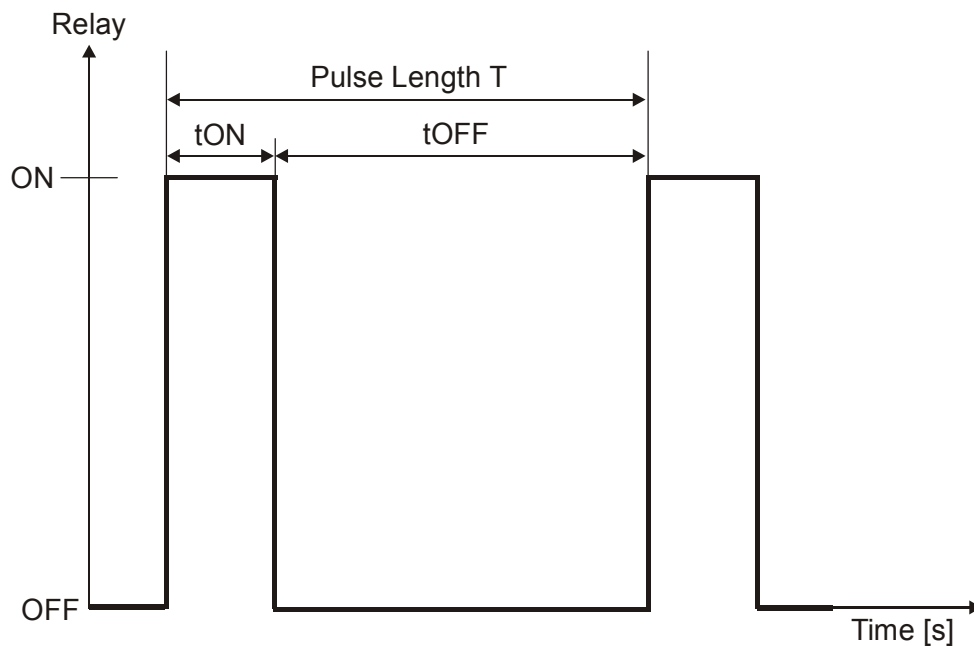

The output relay of the pulse length controller is clock-timed. The switching period T remains constant. Depending on the divergence from the limit value, the switch on time t_{ON} is increased or decreased in accordance with the proportional range X_p .

The following applies:

$$t_{ON} + t_{OFF} = T \text{ (Const.)}$$

greater divergence \rightarrow greater t_{ON}

X_p exceeded $\rightarrow t_{ON} = T$ (relay remains picked up)

11.4.5 Control signal of Pulse Frequency Controllers

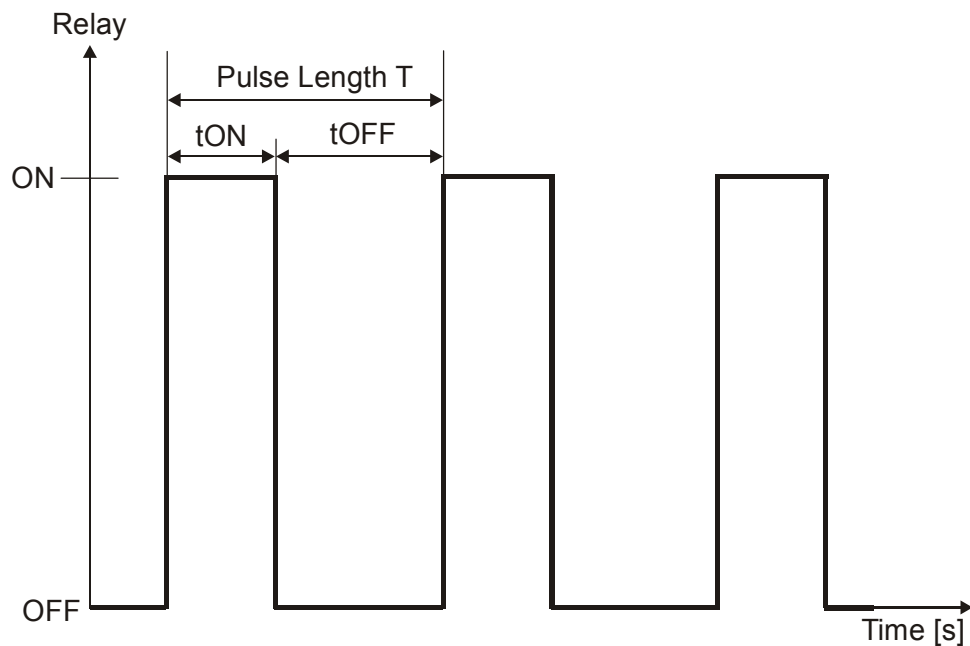

The output relay of the pulse frequency controller is clock-timed. The pulse duration t_{ON} remains constant at 250 msec. Depending on the divergence from the limit value, the frequency ($1/T$) is increased or decreased in accordance with the proportional range X_p .

The following applies:

$t_{ON} = \text{Const. (250 msec.)}$

greater divergence \rightarrow greater f (greater frequency)

X_p exceeded \rightarrow max. frequency

11.5 Appendix 5 – Abbreviations used in menu displays

Abbreviation	Meaning
MEAS	Measurement
CAL	Calibration
ENT	Enter
C. CD	Calibration security code
S. CD	Setup security code
1-PT CAL	One Point Calibration
2-PT CAL	Two Point Calibration
LO	Low Point
HI	High Point
OFS	Offset
P.	Process
C.	Calibration
SET	Setting
ATC	Automatic temperature calibration
SP1	Set point 1
SP2	Set point 2
LO	Low limit
HI	High limit
HYS	Hysteresis
ON. D	On delay
OFF. D	Off delay
CNTR	Controller
L. CT	Limit control
PLC	Pulse length control
PFC	Pulse frequency control
P/PI	Proportional control
EN	Energized
DEEN	Deenergized
REL	Relay
PRP	Proportional band
T. PL	Pulse length time

Abbreviation	Meaning
F. PF	Pulse frequency
IAT	Integral action time
MANU	Manual
CUR 1	Output current 1
CUR 2	Output current 2
OUT	Output signal
4 - 20	4 to 20mA
0 - 20	0 to 20 mA
R.0	Value at 0 mA
R. 4	Value at 4 mA
R. 20	Value at 20 mA
CU22	Out of range output current 22 mA
WASH	Wash
H. INT	Cleaning interval in hours
S. DUR	Cleaning duration in seconds
CNFG	Configuration
BKLT	Back light
LEVL	Level
SAL	Salinity
BAR	Barometric Pressure
PAS	Pascal
mmHg	mm Mercury
PSI	Pounds per Square Inch
AL.C	Alarm Contact
STDY	Steady
FLET	Fleet, impulse
AL. D	Alarm delay
EL	Electrode Type
0-10	0-10 ppm measurement range
0-40	0.5-40 ppm measurement range
DEF	Default

For more information on the products, contact your nearest distributor or visit our website listed below:

<p>Eutech Instruments Pte Ltd. Blk 55, Ayer Rajah Crescent, #04-16/24 Singapore 139949 Tel: (65) 6778 6876 Fax: (65) 6773 0836 E-mail: marketing@eutechinst.com Web-site: www.eutechinst.com</p>	<p>Distributed by:</p>
----------------------------------------------------------------------------------------------------------------------------------------------------------------------------------------------------------------------------------------------------------------------------------------------------------------	------------------------