

# Instruction Manual

## pH/Ion 510

Bench pH/Ion/mV Meter



**OAKTON®**

**CE**

**EUTECH  
INSTRUMENTS**

*Technology Made Easy...*

**ISO 9001  
CERTIFIED**

68X090811  
Rev. 8 DEC 06



## **PREFACE**

Thank you for choosing the pH 510 pH/mV/Temperature or Ion 510 Ion/pH/mV/Temperature bench meter.

The instruction manual functions in two ways: firstly as a step-by-step guide to help you operate the 510 series meter. Secondly, it serves as a handy reference guide.

The instruction manual is written to cover as many anticipated applications of the pH/Ion 510 Bench meter series as possible. If there are doubts in the use of the instrument, do not hesitate to contact the nearest Authorized Distributor.

Eutech Instruments/ Oakton Instruments cannot accept any responsibility for damage or malfunction to the meter caused by improper use of the instrument.

The information presented in this manual is subject to change without notice as improvements are made, and does not represent a commitment on the part of Eutech Instruments Pte Ltd/ Oakton Instruments.

**Note: Eutech Instruments Pte Ltd/ Oakton Instruments reserves the right to make improvements in design, construction, and appearance of our products without notice.**

Copyright © 2002 All rights reserved.  
Eutech Instruments Pte Ltd  
Oakton Instruments

Rev.8 DEC 06

# TABLE OF CONTENTS

<b>1</b>	<b>INTRODUCTION.....</b>	<b>1</b>
1.1	Introducing the 510 Bench Series.....	1
1.2	Custom LCD.....	1
1.3	Keypad.....	2
1.4	Rear Instrument Panel.....	3
<b>2</b>	<b>STARTING UP.....</b>	<b>4</b>
2.1	Connecting the Sensor Electrode.....	4
2.2	Connecting the Temperature Probe.....	4
2.3	Connecting the A/C Adapter.....	4
2.4	Connecting the Chart Recorder.....	4
2.5	Connecting the Electrode Holder (Optional).....	5
2.6	Steps Prior to Calibration.....	6
<b>3</b>	<b>CALIBRATION.....</b>	<b>6</b>
3.1	pH Calibration.....	6
3.2	Ion Concentration Calibration (For Ion 510 only).....	9
3.3	mV Calibration.....	11
3.4	Temperature Calibration.....	12
<b>4</b>	<b>MEASUREMENT.....</b>	<b>13</b>
4.1	Automatic Temperature Compensation (ATC).....	13
4.2	Manual Temperature Compensation (MTC).....	13
4.3	Taking Measurements.....	14
4.4	HOLD Function.....	15
4.5	Storing and Recalling Data from Memory.....	15
<b>5</b>	<b>SETUP FUNCTIONS.....</b>	<b>17</b>
5.1	P1.0 Clear Memory.....	17
5.2	P2.0 Viewing Electrode Diagnosis.....	18
5.3	P3.0 Selecting pH Buffer Standard and No of Calibration Points.....	19
5.4	P4.0 Meter Reset.....	20
<b>6</b>	<b>pH Electrode Maintenance.....</b>	<b>21</b>
6.1	Storage.....	21
6.2	After Use.....	21
6.3	Electrode Cleaning.....	22
6.4	pH Electrode Rejuvenation.....	23
<b>7</b>	<b>TROUBLESHOOTING GUIDE.....</b>	<b>24</b>
7.1	Error Messages.....	24
7.2	Troubleshooting.....	25
<b>8</b>	<b>ADDITIONAL INFORMATION.....</b>	<b>26</b>
8.1	pH and Temperature.....	26
8.2	Use of Standard pH Buffers.....	26
8.3	Standard pH Buffers.....	26
8.4	List of Accessories.....	27
8.5	Specifications.....	29
<b>9</b>	<b>WARRANTY.....</b>	<b>30</b>
<b>10</b>	<b>RETURN OF ITEMS.....</b>	<b>30</b>

# 1 INTRODUCTION

## 1.1 Introducing the 510 Bench Series

The pH 510 and Ion 510 bench meters are microprocessor-based which incorporates new ASIC (Application Specific Integrated Circuit). It is designed with convenience in mind, and offers many advanced user-friendly features. The meters are capable of storing and recalling up to 100 data sets in its non-volatile memory. In addition, as a space saver, an optional swivel electrode holder can be attached at the either side of bench meter for resting the electrodes and probes during operation.

The pH 510 meter is capable of measuring pH/ORP with Temperature; while the Ion 510 meter measures Ion Concentration/pH/ORP with temperature. It is equipped with a large customized LCD (Liquid Crystal Display) with simultaneous display of the measured values for easy reading. It is most ideal for routine pH/Ion Concentration measurement in indoor applications.

## 1.2 Custom LCD

The 510 meter is characterized by a large custom dual LCD. The display has mode annunciators for pH, mV, ppm and temperature readings. The secondary (lower) display shows the temperature reading simultaneously with the primary (upper) display that shows the measured values of pH, ppm or mV. Special annunciators such as units of measure, error message, graphical icons and modes of operation are arranged around both primary and secondary display to give you a comprehensive yet uncluttered display.

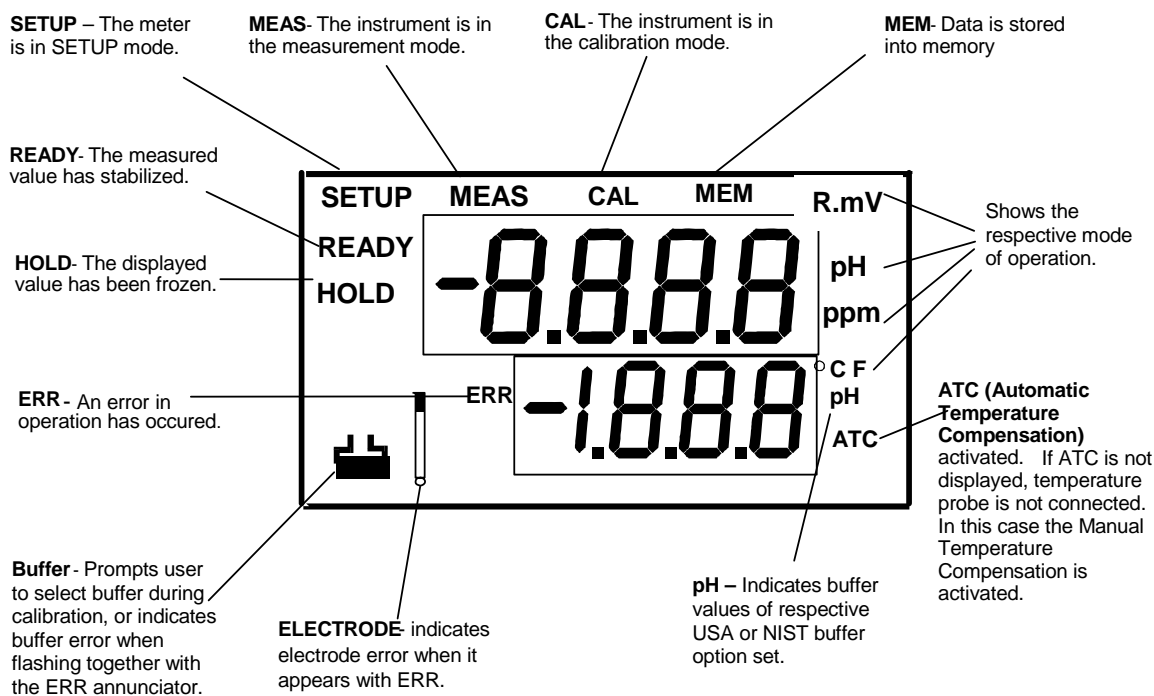

### 1.3 Keypad

A large splash proof membrane keypad with tactile feedback makes meter easy to use. Names and symbols describe the function button controls.

Key	Measurement Mode	Calibration / Setup Mode
<b>ON/OFF</b>	Powers the meter ON/OFF. When the meter is switched on, it automatically starts in the last mode of operation.	~
<b>CAL/MEAS</b>	Toggles between the measurement and calibration modes of the meter. In SETUP mode, pressing CAL/MEAS key returns to the measurement mode.	~
<b>MODE</b>	Toggles between the different measurement modes available pH/Temperature/mV/Ion. (Ion mode only applies with the ION 510.)	Switches from pH to Temperature in pH calibration mode
<b>MI/▲</b>	<b>MI</b> inputs measurements into memory and scrolls through memory values.	▲ scrolls values in mV calibration mode and selects temperature values and ion options in calibration mode. Scrolls to next program in the SETUP mode.
<b>MR/▼</b>	<b>MR</b> recalls measurements from memory and scrolls through memory values.	▼ scrolls values in mV calibration mode and selects temperature values and ion options in calibration mode. Scrolls to next program in the SETUP mode.
<b>HOLD</b>	Freezes a measurement on the display. Press again to get current readings.	~
<b>ENTER</b>	Enter functions in the memory mode.	Confirms and enters the value selected for calibration.

You can also configure functions like Meter Reset, Memory Clear and Selection of pH Buffer Standard via the keypad. Please refer to Section 5 for more information on the above functions.

### 1.4 Rear Instrument Panel

This 510 series meter provides a complete set of connectors for the various accessories commonly used. Listed in the table are the details of the connections that you can make.

Rear View of Meter

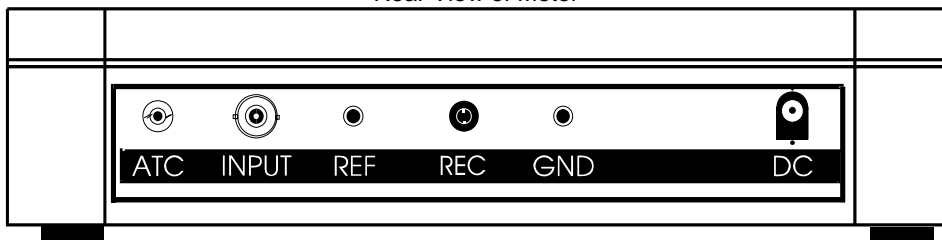

Connection	Function
<b>ATC</b>	For phono jack connection from the temperature probe for Automatic Temperature compensation. The probe should be a 30KΩ thermistor type.
<b>INPUT</b>	For connection to sensor electrodes with BNC type connectors. The meter accepts any pH, ORP or ISE with BNC connector. Always ensure that the connector is clean and dry.
<b>REF</b>	For connection to pin type reference electrode normally used with half cell (mono) type pH electrodes or ISEs.
<b>REC</b>	For connection to strip chart recorders. Use subminiature plug with positive tip.
<b>GND</b>	For connection to the ground earth jack (standard tip connectors).
<b>DC</b>	For connection for the AC/DC power adapter

## 2 STARTING UP

Connect the accessory connectors at the rear of the instrument panel. During operation, it is important that water does not get onto the BNC connector. Also avoid touching the connector with soiled or wet hands.

### 2.1 Connecting the Sensor Electrode

Slide the electrode connector of the electrode over the socket of the meter's BNC connector marked 'INPUT'. The meter can accept any standard pH, ORP, or Ion Selective Electrode with a BNC connector. Align the slot of the electrode connector with the posts of the socket. Rotate the connector clockwise until it locks. For separate reference electrodes, push the electrode pin into jack marked 'REF'.

### 2.2 Connecting the Temperature Probe

Insert the temperature probe (provided) into the connector marked 'ATC'.

### 2.3 Connecting the A/C Adapter

Slide in the adapter jack of the A/C adapter into the back panel marked 'DC' until it is firmly seated. Ensure that the power is switched off before installation and the correct voltage adapter is used.

### 2.4 Connecting the Chart Recorder

You can connect chart recorders or external output devices for continuous printout. Plug in the input connector and ground pin of the chart recorder into the ports marked 'REC' and 'GND' respectively.

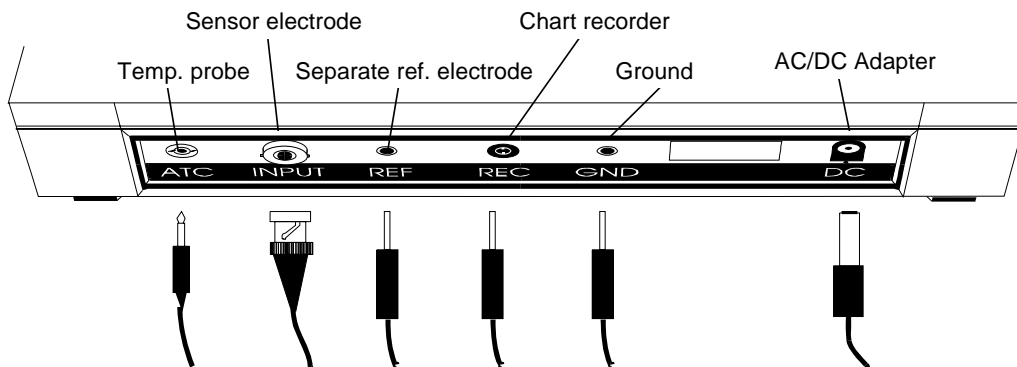

## 2.5 Connecting the Electrode Holder (Optional)

The integral electrode holder serves as a handy holder for mounting a few pH/Ion electrodes or a temperature probe during measurement or when idle.

This meter's base plate has a side metal bar to which you can attach an integral swivel electrode holder. You can mount the electrode holder on either right or left side of the meter.

### To position the electrode arm:

Use a Phillips screwdriver to remove the screw holding the electrode holder. Slide the side metal bar until the second screw slot lines up with the original screw hole. Use the screw removed earlier to secure the electrode holder into position.

**NOTE:** The side metal bar is reversible. If desired, remove screw holding electrode holder base and slide out of brackets, Slide base into brackets on opposite side and tighten screw.

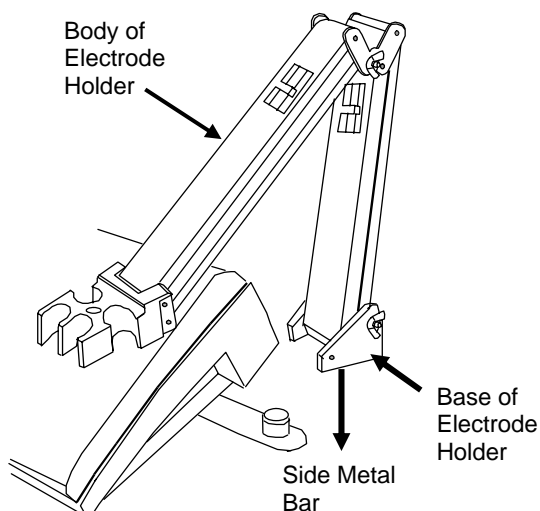
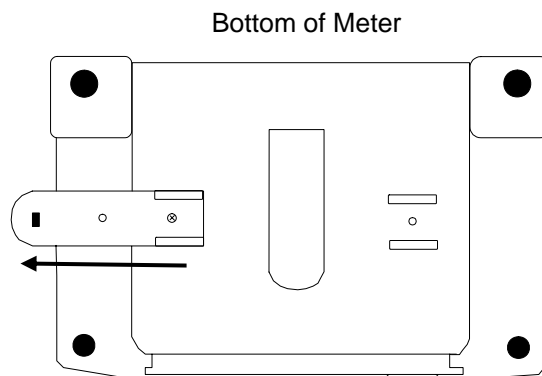

### To install the electrode arm to the meter:

To mount the electrode arm into the metal rod on the side bar, align the slot with the metal rod and base of electrode arm. Push it downwards until it fully sits into position. Avoid using excessive force when fixing or removing. The electrode arm is ready for use.

**NOTE:** Move the base of the electrode holder if you wish to swing the electrode holder about. To prevent the meter from toppling over causing accidental spills, **DO NOT** swing the body of the electrode holder.

## 2.6 Steps Prior to Calibration

---

### 2.6.1 Switching 'ON' and 'OFF' the meter

---

Press **ON** key to switch meter on. All the LCD segments will display momentarily for a few seconds and the LCD then switches to the last measurement mode. To switch meter off, press **OFF** key.

### 2.6.2 Selecting Measurement Mode

---

The measurement modes available for the pH 510 meter are pH, mV (for ORP) and Temperature, while the Ion 510 meter has Ion, pH, mV and Temperature measurement modes. Select the correct mode of operation by pressing the **MODE** key, and each press takes you to next measurement mode. When selecting a particular parameter the respective mode annunciator displays at the right hand side of primary display; these include [pH] for pH, [°C] for Temperature, [ppm] for Ion Concentration and [mV] for Millivolt.

### 2.6.3 Meter Reset

---

On first use, it is not necessary to reset meter before calibration as it has been factory-calibrated. However if you wish to reset the meter to factory default refer to Section 5.4.

**NOTE:** Re-calibration of meter is required before measurement after the meter is reset. Likewise if you wish to prepare a new set of measurements, you may reset all the last calibrated pH values simultaneously for added convenience. **Caution: All calibration values and memory data will be erased upon activation. Re-calibration is required.**

### 2.6.4 Selecting pH Buffer Standard

---

The meter is capable of calibrating based on either USA or NIST pH buffer standards. Please refer to Section 5.3 P3.0 for details on how to change the USA buffer standard to the NIST standard on the meter itself. Refer to Section 8.3 for more details on pH buffer standards available.

**NOTE:** Remove protective rubber cap or storage bottle (if any) from the electrode before proceeding with measurement or calibration. Take care not to exert too much force as this may cause damage to the electrode. Whenever the electrode is not in use, put it into storage bottle or protect the electrode with the rubber cap provided. Refer to the Section 6 on Probe Maintenance for more details.

---

---

## 3 CALIBRATION

---

### 3.1 pH Calibration

---

The 510 series bench meter is capable of multi-point calibration (up to 5 points) for high accuracy across the measurement range. The 5-point calibration offers flexibility of calibrating using either USA or NIST buffer standards with their 5 internationally accepted calibration points namely:

USA standard buffer options: pH1.68, 4.01, 7.00, 10.01, 12.45

NIST standard buffer options: pH1.68, 4.01, 6.86, 9.18, 12.45

For ATC measurements, attach the temperature probe to the meter. The ATC mode annunciator shows on the display. Insert the probe into the solution to be measured so that the sample temperature can be recorded and pH readings automatically temperature compensated. If manual temperature compensation is preferred, do not plug a temperature probe into the meter.

**DO NOT REUSE SOLUTIONS AFTER CALIBRATION.** Contaminants in the solution can affect the calibration, and eventually the accuracy of the measurements.



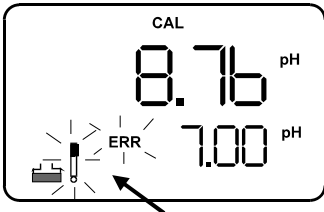

Figure 2: Calibration error

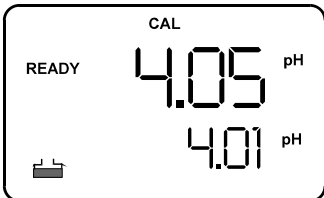

Figure 3: 2nd-point calibration

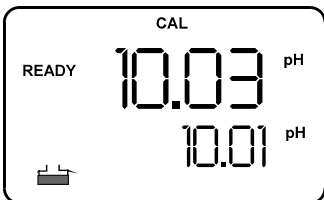

Figure 4: 3rd-point calibration

**HINT: If the selected buffer value is not within the accepted window (see below) from the measured value: the electrode and buffer icon blink and ERR annunciator appears next to the secondary display. (See Figure 2 above) Press CAL/MEAS key to exit the ERR condition.**

**Window of Accepted Values:-**

<b>USA</b>	1.68	±1.00
	4.01	±1.00
	7.00	±1.50
	10.01	±1.00
	12.45	±1.00
<b>NIST</b>	1.68	±1.00
	4.01	±1.00
	6.86	±1.25
	9.18	±1.00
	12.45	±1.00

7. Wait for the measured pH value to stabilize (when the [READY] indicator displays in the left-hand corner).

**NOTE**

If the upper measured display is not within the buffer acceptable window (refer to Hint below) an error message and the electrode icon flash upon pressing the **ENTER** key. Refer to Section 7, Troubleshooting Guide. Check electrode condition and recalibrate. Press **CAL/MEAS** key to exit calibration and resume to the measurement mode.

8. Press the **ENTER** key to confirm the calibration. The upper display flashes the calibration value momentarily before storing the calibration point in the meter. The lower display then toggles between the next calibration buffer values.
9. If you are performing a one-point calibration, press **CAL/MEAS** key to return to the measurement mode and start taking pH readings (see Figure 1).

**NOTE**

To exit from pH calibration mode without confirming calibration, **DO NOT** press **ENTER** key in step 9. Press the **CAL/MEAS** key instead.

**Two to Five Point Calibration**

10. If you are performing a multi-point calibration (i.e. second-point or more) go to step 11.
11. Rinse the probes with deionized water or rinse solution to avoid cross contamination, and place them in the next pH buffer, say pH 4.01 buffer. The lower display of the meter automatically switches to the pH buffer solution selected.
12. Wait for the measured pH value to stabilize (when the [READY] indicator displays in the left-hand corner). (see Figure 3).
13. Press the **ENTER** key to confirm the calibration. The upper display flashes the calibration value momentarily before storing the calibration point in the meter. The lower display then switch to the next calibration buffer value.
14. If you are performing a two-point calibration, then press the **CAL/MEAS** key to return to the measurement mode and start taking pH readings.
15. If you are performing a three-point calibration go to step 16.
16. Rinse the probes with deionized water or rinse solution, and place them in the next pH buffer as indicated in the lower display, say pH 10.01 buffer.
17. Wait for the measured pH value to stabilize (when the [READY] indicator displays in the left-hand corner) (see Figure 4).
18. Press the **ENTER** key to confirm the calibration. The upper display flashes the calibration value and then stores the calibration point in the meter. The meter automatically returns to the pH measurement mode after a three-point calibration is performed (since meter is defaulted to 3-point calibration). To perform four or five-point calibration, you need to select the calibration points based on the procedure in page 19 before repeating the calibration procedure as the above.

### 3.2 Ion Concentration Calibration (For Ion 510 only)

The Ion 510 meter is capable of up to 3-point ion calibration (minimum 2 point) using 5 ion calibration options namely 0.10, 1.0, 10.0, 100.0 or 1000 ppm to ensure accuracy across the entire measurement range. All calibration should be at least one decade apart from each other. Note that the ion measurement mode accepts input of only  $\pm 500$  mV. For example you may perform 3 point calibration to 0.10, 1.0 and 10.0, or 2-point calibration to 10.0 and 100.0. If 1-point calibration is performed an error message "Er2" is displayed. If any of calibration points are not within 1 decade, an error message "Er4" will be displayed at the end of calibration process.

Calibration values are successfully stored if the ISE slope is within the specified tolerance of 15mV/decade (minimum) and 90mV/decade (maximum), otherwise an error message "Er3" is displayed (see Figure 7). The calibration values are not stored into the meter's built-in memory if any error message appears after each calibration process. Re-calibration is necessary as calibration is unsuccessfully attempted in this instance. Check that your ISE and standard solutions are in good working conditions.

Ensure that you use new or fresh standard solutions during calibration. Do not reuse ion standard solution as it may be contaminated and affect the calibration and accuracy of measurements. Always store standard solutions in a dry, cool environment if possible. Before use, remove plastic protective cap of ISE. Briefly rinse the electrode with clean deionized water to remove any residues.

Rinse probes before and after each calibration or sample measurement to avoid cross-contamination. For more details please refer to Manufacturer's care and maintenance guide.

**NOTE: The ion calibration values will be lost once power is disconnected; only pH and mV calibration values will be retained.**

1. Connect an Ion Selective Electrode (ISE) to the BNC input connector on the back of the meter. Turn the meter **ON**.
2. Press **MODE** key (if needed) to select ion measurement mode. If there is no old calibration values, then the meter displays "----" in the upper display in measurement mode.
3. Dip the ISE into the first calibration standard. Make sure to start with the calibration standard that has the lowest concentration and move up to the standards that have higher concentrations.

Swirl it gently. Press **CAL** key to enter the ion calibration mode. The [CAL] indicator appears above the upper display and the upper display reads "0.10". The lower display shows the corresponding absolute mV value of sample measured.

4. The first calibration point of **0.10 ppm** appears on the display. If you **DO NOT** wish to calibrate to this point, press MI(up arrow) key to skip and continue to the next calibration point of 1.0 ppm or 10.0 ppm.
5. If you **DO** wish to calibrate to 0.10 ppm, allow the mV reading to stabilize. When the reading stabilizes the [READY] indicator will appear on the display. Stabilization may take a few minutes depending on electrode and standard concentration.
6. Press **ENTER** key to confirm your first point calibration (see Figure 5). After calibration, the display will show the next calibration option, i.e. **1.0 ppm**. Proceed by rinsing the electrode with deionized water before placing it in the next calibration standard i.e. 1.0 ppm.
7. Allow the meter to stabilize in the next calibration standard. Wait for the [READY] indicator to appear before you press the **ENTER** key to confirm the second calibration point. The upper display flashes momentarily then moves to the next calibration point of 10.0 ppm.

**NOTE:** If you are performing a 2-point ion calibration, press **CAL/MEAS** key. "SLO" appears in the upper display with the [mV] indicator and the number in the lower display is the electrode slope in mV (see Figure 6). You are ready to take ion measurements. If the slope is outside the acceptable limits or if incorrect standards have been used the upper display will show "Er3" (see Figure 7).

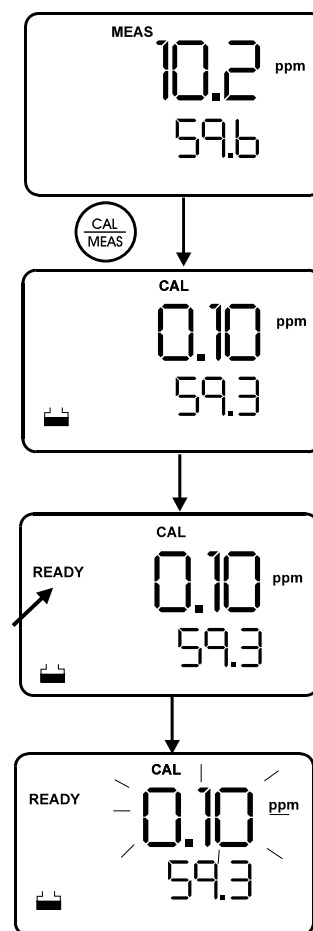

Figure 5: 1st-point calibration

If you are performing a 3 point calibration, rinse off the electrode with deionized water, place it in the next calibration standard and proceed as follows.

8. Allow meter to stabilize in the next calibration standard. Wait for the [READY] indicator to appear before you press the **ENTER** key to confirm the third calibration point. The upper display flashes for a few seconds then "SLO" appears in the upper display with the mV indicator, the number in the lower display is the average electrode slope in mV (see Figure 6). After a few seconds the meter reverts to the measurement mode. You are now ready to take ion measurement.

**NOTE:** All the calibration values are successfully stored. Otherwise error message will appear in the LCD if the calibration was unsuccessful with no values stored into memory.

**NOTE:** You may compare the average electrode slope value with the expected slope value for your electrode from your electrode manual to verify electrode operation.

**HINT: Minimum of 2 points and maximum of 3 points are allowed for Ion Calibration. All calibration points should be at least one decade apart, i.e. valid calibration points are 0.1, 1, 10 ppm or 1, 10, 100 ppm or 0.1, 1 ppm or 1, 10 ppm or 10, 100, 1000 ppm.**

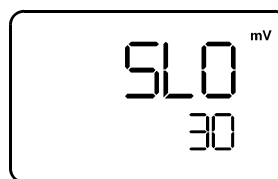

Figure 6: Slope value in mV

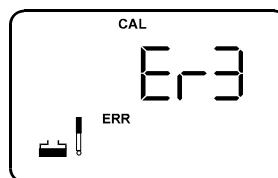

Figure 7: Error message Er3 if slope not within range

### 3.3 mV Calibration

1. Make sure the meter is on and if necessary, press the **MODE** key to select mV mode. The [mV] indicator appears in the upper right-hand corner of the display.
2. Press the **CAL/MEAS** key. The [CAL] indicator appears above the upper display that displays the relative mV reading. The lower display shows the absolute mV value.

**NOTE:** If you have never calibrated relative mV or if the meter has been reset, the value shown in the upper display is the same as the absolute mV value. The range of adjustment is -1999 mV to 1999 mV (resolution is 1 mV); of which from -199.9 to 199.9 mV the meter gives you a resolution of 0.1 mV.

3. Press  $\blacktriangle$  or  $\blacktriangledown$  key to enter the relative mV value that matches your desired reading.
4. Press the **ENTER** key to confirm the reading and the meter automatically returns to the measurement mode. The upper display now shows the relative mV reading. The [R.mV] indicator appears in the upper right hand corner.

**NOTE:** New mV calibrations will override existing stored mV calibration data. The meter retains stored mV calibrations even when the meter is turned off.

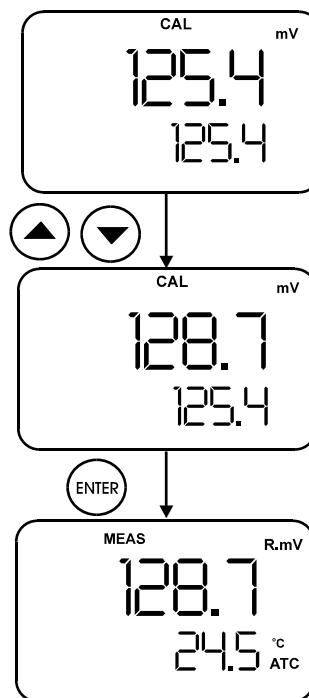

### 3.4 Temperature Calibration

In this calibration procedure, the ATC probe is attached to the meter and the [ATC] annunciator is displayed on the right hand side of the LCD.

1. Dip the temperature probe into a solution of known temperature, such as a temperature bath for a few minutes until the temperature probe stabilizes.
2. To perform temperature calibration, you must be in the pH measurement mode.
3. Press **MODE** key to switch to the pH measurement mode if you are in the mV or ion measurement modes.
4. Press **CAL/MEAS** key to enter pH calibration mode.
5. Press **MODE** key again to switch to temperature calibration.
6. Press  $\blacktriangle$  or  $\blacktriangledown$  key to scroll to the correct temperature value corresponding to the known solution temperature. The meter allows a limit of  $\pm 5$  °C variation (with 0.1 °C resolution) of the input reading, and of the original displayed reading.
7. Once you selected the correct temperature, press **ENTER** key to confirm. The meter automatically returns to the pH measurement mode.

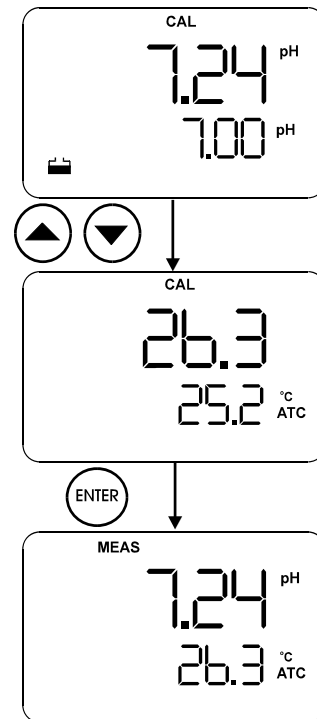

## 4 MEASUREMENT

### 4.1 Automatic Temperature Compensation (ATC)

For ATC measurements, simply attach the temperature probe into the meter (see Section 2.2). The [ATC] annunciator lights up on the LCD.

**NOTE**

If you are using a temperature probe, the probe must be submersed in the liquid you are measuring so that the sample temperature can be recorded and compensated for.

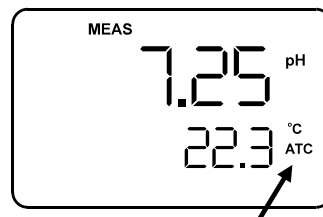

### 4.2 Manual Temperature Compensation (MTC)

**Important:** For MTC, you must disconnect the temperature probe.

1. Switch the meter on. Press the **MODE** key to select pH mode.
2. Press the **CAL/MEAS** key to enter pH calibration mode. The CAL annunciator appears above the upper display.
3. While in pH calibration mode, press the **MODE** key to enter temperature compensation mode. The upper display shows the current temperature setting and the lower display shows the default value 25.0 °C (if the meter has never been manually set for temperature) or the last manually set value if the meter has previously set for MTC. If you have not set the current temperature setting the upper display will also show the default value of 25.0 °C.
4. Check the temperature of your sample using an accurate thermometer.
5. Press **▲** or **▼** key to offset the temperature to the measured value from step 4.
6. Press **ENTER** key to confirm the selected temperature and return to the pH measurement mode.

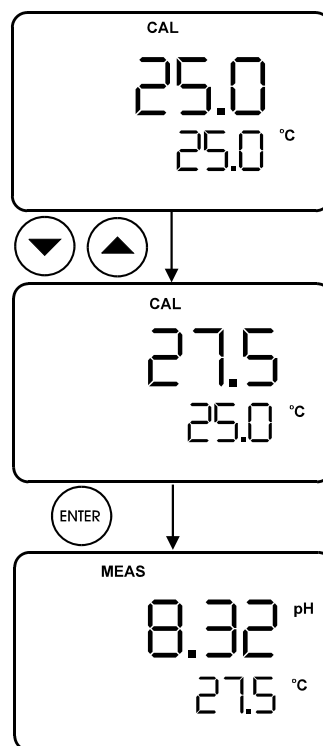

**NOTE**

To exit this program without confirming the MTC value, **DO NOT** press **ENTER** key in step 6. Press **CAL/MEAS** key instead.

The meter will compensate pH reading for the manually set temperature.

### 4.3 Taking Measurements

---

Be sure to remove any electrode soaker bottle or protective rubber cap from the electrode before measurement.

To take readings:

1. Rinse the electrode with distilled or tap water before use to remove any impurities adhering to the electrode body. If the pH electrode had dehydrated, soak it for 30 minutes in EC-RE005/ 00653-04 electrode storage solution. (See Electrode Care - Section 6)
2. Press **ON** key to switch on meter. The [MEAS] annunciator appears on the top center of LCD. The ATC annunciator appears in the lower right hand corner to indicate ATC if a temperature probe is plugged. (For MTC, refer to Section 4.2).
3. Dip the electrode and temperature probe into the sample, making sure that the glass bulb of the electrode must be completely immersed into the sample. Stir the probes gently to create a homogeneous sample.
4. Allow time for reading to stabilize. When the readings stabilize, a [READY] annunciator displays. The READY mode shows the readings are stable within a range of  $\pm 0.01$  pH. When this occurs, the [READY] annunciator appears on the top left side of LCD. Take the reading.
5. To toggle between pH and mV in the pH510, or to toggle between pH, mV and Ion in the Ion 510, press the **MODE** key.

#### 4.4 HOLD Function

This feature lets you freeze the value of the measured reading. HOLD can be used anytime when in [MEAS] mode. You can store the held reading into memory by pressing **MI** key.

##### HOLDing a measurement

To hold a measurement, press the **HOLD** key while in measurement mode. [HOLD] annunciator will appear on the display.

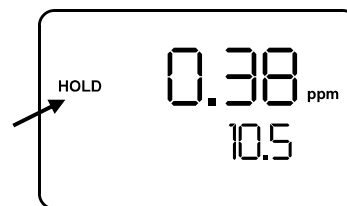

##### Releasing a Held Value

To release the held value, press **HOLD** key again. [HOLD] annunciator will disappear from the LCD. Continue to take measurements.

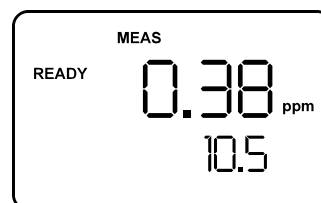

#### 4.5 Storing and Recalling Data from Memory

The meters allow up to 100 data sets to be stored and recalled into its non-volatile memory in the Last-In-First-Out (LIFO) sequence. The data set is also stored with specified location as indicated on the display. However you can selectively view the data at that specified location for added convenience.

##### pH 510 meter:

- pH and Temperature
- mV (or Relative mV) and temperature

##### Ion 510 meter:

- pH and Temperature
- mV (or Relative mV) and temperature
- ion and mV

For example you can store 32 pH and 18 mV values for the pH 510 or 15 ion, 12 mV and 23 pH values for the Ion 510.

##### Memory Input

This feature allows you to store measurement readings into memory for later review. This mode can be invoked at any time during measurement mode or when the reading is frozen ([HOLD] annunciator is displayed on LCD by the activation of HOLD key).

##### To store reading:

1. During any measurement or HOLD function, press the **MI** key once to input data into the memory.
2. [MEM] annunciator, "StO" and memory number will flash momentarily. The meter then returns to the measurement mode.
3. To continue storing data, press **MI** key again.

**NOTE:** If the memory is full, the first value stored will be erased to create space for the new value.

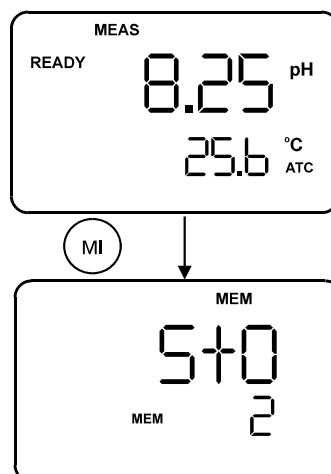

**Memory Recall**

1. In the measurement mode, press **MR** key once to retrieve the last reading stored. The memory location screen – “MEM”, “LOC” and the memory number – will flash on the display.
2. Press the **ENTER** key to recall the reading stored under that memory number.
3. If necessary, you can selectively choose to view any data that is stored by using **▲** or **▼** key. For example to view the third data location set to LOC 3 from last stored location of LOC 5. Use **▲** or **▼** key to set to LOC 3. Press **ENTER** key to retrieve the data from this location.
4. To continue reviewing additional stored data, press **ENTER** key again. For this instance the next location, LOC 2, will be displayed.
5. To exit Memory Recall and operate meter, press the **MEAS** key to return to the measurement mode.

**NOTE:** Readings stored in memory are retained even of the unit is turned off. To erase all readings stored in memory, see Program P1.0 on the next page.

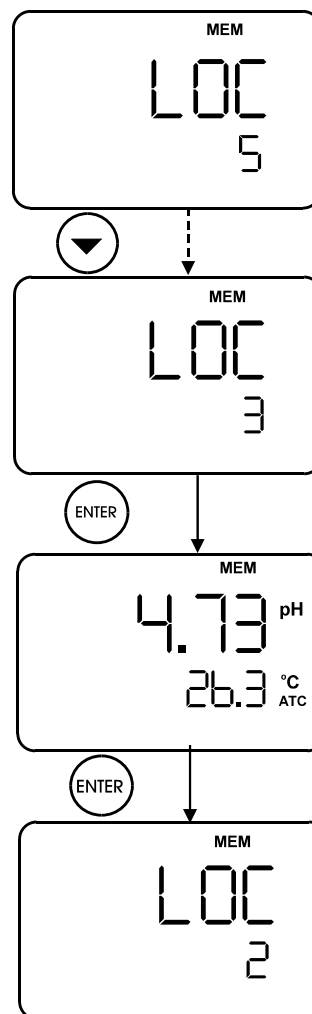

## 5 SETUP FUNCTIONS

The advanced SETUP mode lets you customize your meter's preferences and defaults:

- P1.0:** Memory Clear (**Clr**)
- P2.0:** Viewing electrode data (**ELE**)
- P3.0:** Selecting buffer sets (**bUF**)
- P4.0:** Reset to factory default settings (**rSt**)

### To enter the SETUP mode:

1. Turn meter **OFF**.
2. With meter off, press and hold the **MODE** key, and press and release the **ON** key. The display will show the [SETUP] indicator. If the display indicates you are in the measurement mode turn the meter off and try step 2 again until [SETUP] appears.

**NOTE:** To exit the SETUP mode at anytime without confirming changes press **CAL/MEAS** until the measurement mode appears. You may have to press **CAL/MEAS** key two times before the meter reverts to the measurement mode.

### 5.1 P1.0 Clear Memory

Use this program to clear all memory values when you need to store a new series of values. This lets you avoid confusing the old values with the new ones. NO is the default setting.

1. Enter the SETUP mode as described above. The meter automatically goes to program P1.0. Clr appears in the upper display and P1.0 in the lower display.
2. Press the **ENTER** key to access the program and the lower display shows either "nO" or "YES" (depending on last option selected or factory default i.e. nO).
3. Use **▲** or **▼** key to toggle between "nO" or "YES"
4. Press **ENTER** key to confirm selection and return to the SETUP mode. To continue to the next SETUP, press **▲** or **▼** key to select a new program. Otherwise press the **CAL/MEAS** key to return to the measurement mode.

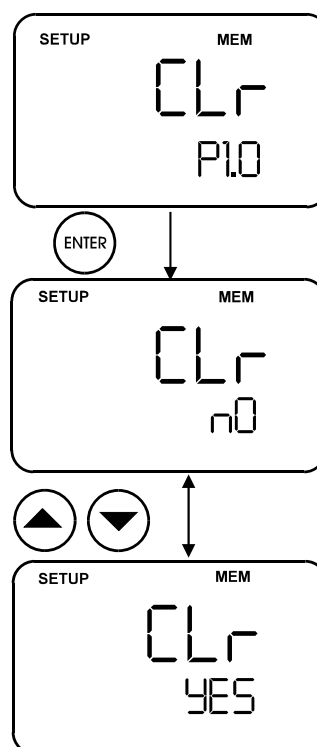

## 5.2 P2.0 Viewing Electrode Diagnosis

This program lets you check the electrode parameters for diagnostic purposes. Depending on the last display mode, displayed electrode information varies. Only these readings can be viewed:

Last Display Mode	Electrode Property	
	Offset	Slope
pH	in mV	%
Ion	-	in mV
mV	in mV	-

1. Enter the SETUP mode as described above. The meter automatically goes to program 1.0.
2. Press  $\blacktriangle$  or  $\blacktriangledown$  key to scroll through the programs until you view ELE in the upper display and P2.0 in the lower display. The electrode annunciator also appears.
3. Press **ENTER** key to access the program P2.0. The lower display will read P2.1.

The information you will see in Program P2.0 will depend upon which MODE the meter was in prior to shutting the meter off:

### In the pH measurement MODE:

P2.1 shows the mV offset of the electrode. Press **ENTER** key to go to P2.2 (see Figure 8).

P2.2 shows the slope in % of the electrode.

### In the mV measurement MODE:

P2.1 shows the mV offset of the electrode (see Figure 9).

### In the Ion measurement MODE:

P2.1 shows the average slope of the electrode (see Figure 10).

4. To exit P2.0 program press **ENTER** key until ELE is in the upper display and P2.0 is in the lower display. Press  $\blacktriangle$  or  $\blacktriangledown$  key to select a new program OR press **CAL/MEAS** key to return to the measurement mode.

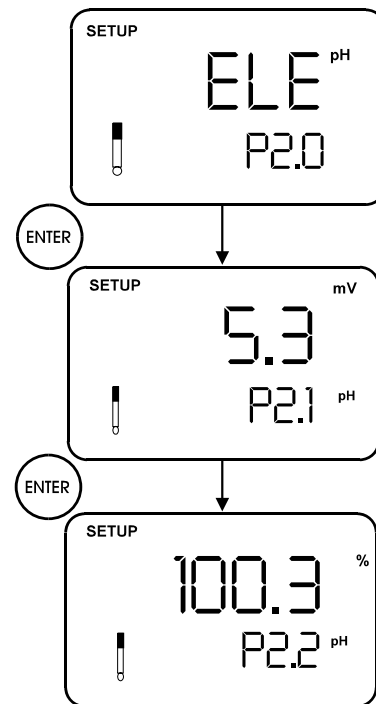

Figure 8: slope in %

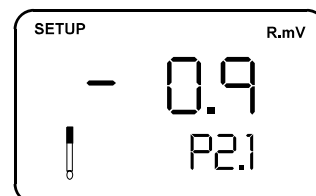

Figure 9: mV offset

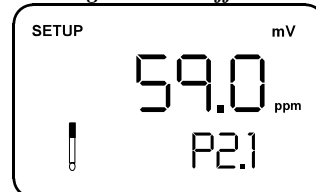
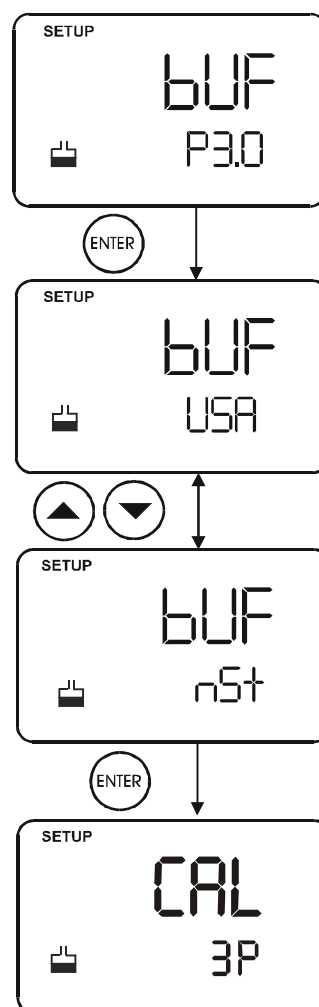

Figure 10: Average slope (mV)

### 5.3 P3.0 Selecting pH Buffer Standard and No of Calibration Points

The available standards are USA and NIST.

1. Enter the SETUP mode as described in this section earlier. The meter automatically goes to program P1.0.
2. Press ▲ or ▼ key to scroll through the programs until you view "**buf**" in the upper display and *P3.0* in the lower display. The buffer annunciator also appears.
3. Press **ENTER** key to access the program P3.0. The lower display will read either "**USA**" or "**nSt**" (depending on the previous setting you have made; factory default is USA.)
4. Press ▲ or ▼ key to select the buffer set you require:
  - USA: 1.68, 4.01, 7.00, 10.01, 12.45
  - NIST: 1.68, 4.01, 6.86, 9.18, 12.45
5. To confirm the buffer standard, press **ENTER**. You will now enter the selection mode for calibration points.
6. Press ▲ or ▼ key to select the calibration points that you desire. You can now select from 2 to 5 calibration points.
7. Press **ENTER** to confirm your selection.
8. To exit P3.0 program press ▲ or ▼ key to select a new program OR press the **CAL/MEAS** to return to the measurement mode.



## 5.4 P4.0 Meter Reset

This program gives you the option to either reset the calibration data's of all parameters or reset everything back to factory default condition except for temperature calibrated value and buffer set selection (NIST or USA).

1. Enter the SETUP mode as described in this section earlier on. The meter automatically goes to program P1.0.
2. Press ▲ or ▼ key to scroll through the programs until you view rSt in the upper display and P4.0 in the lower display.
3. Press the **ENTER** key to access the program P4.0. The lower display will read **NO**.
4. Press ▲ or ▼ key to select "**NO**" or "**YES**"
  - **NO** - deactivates the reset function
  - **YES** – Activates the reset option mode
5. Press **ENTER** to confirm your selection.
6. For reset option mode, press ▲ or ▼ key to select "**CAL**" or "**Fct**"
  - **CAL** – clears all calibration datas in all parameters
  - **Fct** – clears everything back to factory default condition except for temperature and buffer set selection (NIST or USA)
7. Press **ENTER** to confirm your reset option. The lower display will flash for a few seconds before the meter returns to program P4.0.

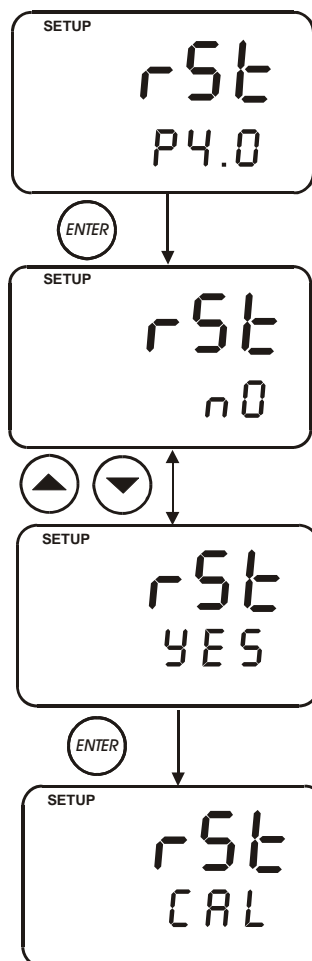

---

## 6 pH ELECTRODE MAINTENANCE

---

pH electrodes are susceptible to dirt and contamination and need to be cleaned regularly depending on the extent and condition of use. Refer to Section 6.3 for more details on cleaning pH electrode.

### 6.1 Storage

For best result, always keep the pH electrode bulb wet, preferably with the use of storage solution. pH 4 buffer is also acceptable as a storage medium. Do not store in deionized water. The protective rubber cap or container filled with the buffer solution provides ideal storage for long periods.

### 6.2 After Use

After measurement is complete, follow the sequence below for storage.

- Wash the electrode and reference junction in de-ionized water
- If using a refillable electrode, close the refilling hole by returning its rubber sleeve or stopper cap into position.
- Store the electrode as mentioned above (see Storage).

#### 6.2.1 Electrolyte Replacement (for refillable electrodes only)

The reference electrolyte needs to be refilled when the pH electrode has been used for an extended period, or when the internal electrolyte has dried up. To accomplish this, follow the procedure:

- Remove the protective rubber cap or sleeve to expose the filling port of the electrode. Remove the old reference electrolyte by flushing out with a syringe and a flexible tube.
- Add in fresh electrolyte until it reaches the level of the refilling port. The reference electrolyte depends on your electrode. For double junction or Calomel electrodes, the electrolyte should be 4M KCl (EC-RE001/ 05992-48). Replace the rubber sleeve.

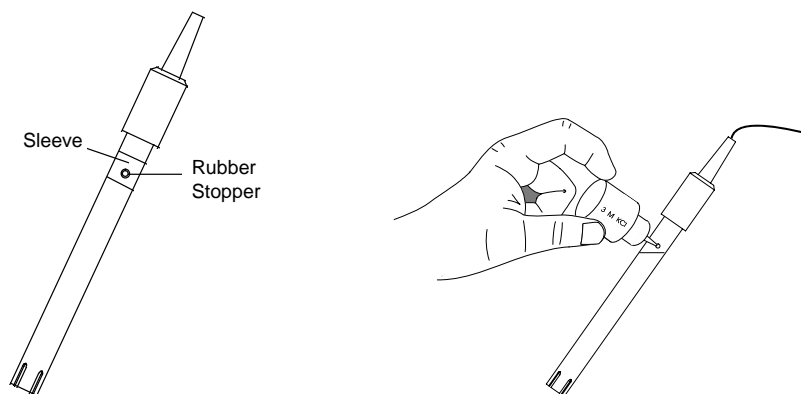

- Rinse the liquid junction with de-ionized water and gently tap dry.

#### **NOTE**

If these steps fail to restore normal electrode response, you may attempt to rejuvenate it. (See: 6.4 pH Electrode Rejuvenation).

### 6.3 Electrode Cleaning

---

pH electrodes that are mechanically intact and not in use for a short period of time can be restored to normal performance by one or a combination of following procedures:

**a) Salt deposits**

Dissolve the salt deposits by immersing the electrode in a container filled with some tap water for ten to fifteen minutes. Then thoroughly rinse with de-ionized water.

**b) Oil / Grease Films**

Wash the pH electrode bulb in mild detergent and water. Rinse electrode tip with de-ionized water.

**c) Clogged Reference Junction**

Heat a dilute 1% KCl solution to 60-80 °C. Place the sensing portion of the pH electrode into heated KCl solution for approximately 10 minutes (as shown above). Care must be taken when performing this procedure. Allow electrode to cool while immersing in some unheated KCl solution. (Heating time confirmed at 10 minutes on our side, pls take note)

**d) Protein Deposits**

Use Protein Cleaning Solution (EC-DPC-BT/ 00653-06) to remove any protein that is deposited onto pH electrode. Allow the electrode to stand in this solution for five to ten minutes.

## 6.4 pH Electrode Rejuvenation

---

**CAUTION:** Proper protective eyewear and precautionary measures must be used when performing the rejuvenation procedure as it involves the use of concentrated acid and alkaline.

Generally, if procedure of storage and maintenance had been closely followed, the pH electrode can be used immediately. However, should the electrode response become sluggish, it may be possible that the glass bulb has dehydrated. Immersing the electrode in an ideal storage solution (e.g. buffer pH 4 solution) for 1- 2 hours can dehydrate the glass bulb. If this fails, the electrode may require re-activation. At no time should you touch or rub the glass bulb as this causes the build-up of electrostatic charge. If the above procedure does not re-activate electrode to acceptable status, try rejuvenating electrode by following the procedure outlined below.

### 6.4.1 Rejuvenation Procedure

---



1. Dip and stir the electrode in freon or alcohol for 5 minutes.
2. Leave the electrode in tap water for 15 minutes.
3. Dip and stir the electrode in concentrated acid (e.g. HCl, H<sub>2</sub>SO<sub>4</sub>) for 5 minutes.
4. Repeat Step 2.
5. Dip and stir in strong base (NaOH) for 5 min. Leave for 15 minutes in tap water.
6. Test with standard calibration buffer solutions.

Finally, test with standard calibration buffer solutions to see if the electrode yields acceptable results. You may repeat steps 3-6 again for better response (maximum 3 times). If the response does not improve, then the electrode has completed its useful life. Replace with a new electrode.

## 7 TROUBLESHOOTING GUIDE

### 7.1 Error Messages

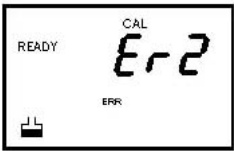
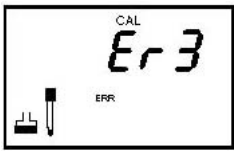
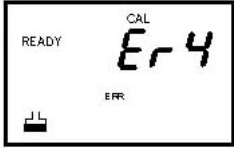
The table provides a quick guideline for diagnosis of possible problems indicated by the messages generated by the 510 meter series. The table also provides possible solutions to problems encountered. Diagrams inserted below.

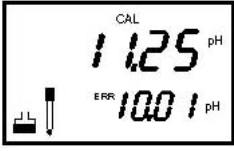
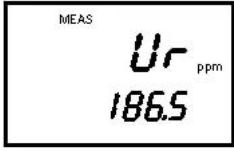
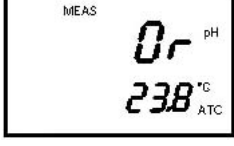
Display Screen	ERROR MESSAGE	INDICATES	CAUSE	CORRECTIVE ACTION
	Err. 2 (in upper display) during Ion calibration	Too few calibration points	Meter calibrated with only 1-point in ion calibration	Recalibrate using 2 or more points
	Err. 3 (in upper display) during Ion calibration	Slope error	Ion calibration solution not within acceptable range (15mV to 90mV/decade)	Recalibrate using fresh ion solutions Replace electrode.
	Err. 4 (in upper display) during Ion calibration	Calibration points more than 1 decade apart	Calibration points more than 1 decade apart	Recalibrate using calibration points 1 decade apart.
	Err (annunciator)	Wrong keypad input	Button does not work in the current operation mode	Release key. Select valid buttons depending on mode.
	Electrode icon (indicator)	Calibration error	Buffer value does not match value displayed or electrode is disconnected or failing	Use fresh buffer solution or check electrode connection. Possibly replace electrodes.
 	Ur or Or (in upper display)	Measured value is out of range	Electrode not connected Electrode clogged, dirty or broken Meter not calibrated. Measurement is under range or over range	Make sure electrode is connected Clean or replace electrode Recalibrate the meter. Treat samples to bring within meter measuring range

## 7.2 Troubleshooting

PROBLEM	PROBABLE CAUSE	REMEDIAL ACTION
No display	a) Mains power not switched on. b) AC Adapter socket not inserted properly.	a) Switch on the power supply. b) Re-insert AC Adapter socket.
Unstable reading	a) Insufficient reference electrolyte in electrode.	a) Fill electrode with reference electrolyte.
	b) Broken electrode	b) Replace electrode.
	c) External 'noises' or induction ( e.g. electrical 'noise' caused by a nearby motor)	c) Remove or switch off interfering device.
	d) Dirty electrode.	d) Clean the electrode. Hydrate, then rejuvenate if necessary.
Slow response	a) Dirty electrode.	a) Clean electrode. Hydrate, then rejuvenate if necessary.
Meter not responding to key press	a) HOLD mode in operation. b) Internal program error.	a) Cancel HOLD mode. Press Hold button. b) Reset all internal programs by removing and reinserting the A/C adapter.

## 8 ADDITIONAL INFORMATION

### 8.1 pH and Temperature

Automatic Temperature Compensation (ATC) compensates for temperature changes. Some solutions show an increase while others a decrease in pH with the same temperature change. Record the solution temperature along with the pH value, or the measurement may be meaningless. Temperature changes also affect the signal the pH electrode sends to the meter and causes a loss of accuracy for the reading. To limit the loss of accuracy during calibration, make the temperature of the pH buffer calibrating solutions and the sample solution the same.

### 8.2 Use of Standard pH Buffers

Use standard buffer solutions to calibrate a pH meter before you measure the pH of a sample. They serve as reference standards for basis of comparison between measurements. The most common USA standard buffers are the pH 1.68, pH 4.01, pH 7.00, pH 10.01 and pH 12.45 and the NIST standard buffers are pH 1.68, 4.01, pH 6.86, pH 9.18 and pH 12.45. For 1-point calibration, use a standard buffer of pH 7.00 or a standard buffer whose pH value is close to that of the sample. Use 2-point calibration when you know the sample is acidic (low pH) or basic (high pH). For acidic samples, use standard buffers of pH 7.00 and pH 4.01. For basic samples, use standards of pH 7.00 and pH 10.01. Use a 5-point calibration when the sample pH is completely unknown. Use all pH 1.68, pH 7.00, pH 4.01, pH 10.1 and pH 12.45 calibration solutions (using a low sodium error electrode).

### 8.3 Standard pH Buffers

The following table shows the various pH values at different temperature of the solution during calibration. The table also illustrates why a calibration value may be different from the buffer value at 25°C.

Temperature (°C)	USA Buffer					NIST Buffer				
	pH 1.68	pH 4.01	pH 7.00	pH 10.01	pH 12.45	pH 1.68	pH 4.01	pH 6.86	pH 9.18	pH 12.45
0	1.67	4.01	7.12	10.32	13.43	1.67	4.01	6.98	9.46	13.43
5	1.67	4.01	7.09	10.25	13.21	1.67	4.01	6.95	9.40	13.21
10	1.67	4.01	7.06	10.18	13.00	1.67	4.01	6.92	9.33	13.00
15	1.67	4.00	7.04	10.12	12.81	1.67	4.00	6.90	9.28	12.81
20	1.68	4.00	7.02	10.06	12.63	1.68	4.00	6.87	9.23	12.63
25	1.68	4.01	7.00	10.01	12.45	1.68	4.01	6.86	9.18	12.45
30	1.69	4.01	6.99	9.97	12.29	1.69	4.01	6.85	9.14	12.29
35	1.69	4.02	6.98	9.93	12.13	1.69	4.02	6.84	9.11	12.13
40	1.70	4.03	6.97	9.89	11.99	1.70	4.03	6.84	9.07	11.99
45	1.70	4.04	6.97	9.86	11.84	1.70	4.04	6.83	9.04	11.84
50	1.71	4.06	6.97	9.83	11.70	1.71	4.06	6.83	9.01	11.70
55	1.72	4.08	6.97	9.81	11.58	1.72	4.08	6.83	8.99	11.58
60	1.73	4.10	6.98	9.79	11.45	1.73	4.10	6.84	8.96	11.45
65	1.73	4.11	6.98	9.77	11.45	1.73	4.11	6.84	8.94	11.45
70	1.74	4.12	6.99	9.76	11.45	1.74	4.12	6.85	8.92	11.45
75	1.75	4.14	6.99	9.75	11.45	1.75	4.14	6.85	8.91	11.45
80	1.77	4.16	7.00	9.74	11.45	1.77	4.16	6.86	8.89	11.45
85	1.78	4.18	7.01	9.73	11.45	1.78	4.18	6.87	8.87	11.45
90	1.80	4.23	7.02	9.73	11.45	1.80	4.23	6.88	8.85	11.45
95	1.81	4.23	7.03	9.74	11.45	1.81	4.23	6.88	8.85	11.45
100	1.81	4.23	7.03	9.74	11.45	1.81	4.23	6.88	8.85	11.45

## 8.4 List of Accessories

### 8.4.1 Replacement Meter and Accessories

Item Description	Eutech Instruments Order Code No.	Oakton Instruments Order Code No.
pH 510 Bench meter complete with temperature probe and integral electrode holder	EC-PH510/01S	35619-10
Ion 510 Bench meter complete with temperature probe and integral electrode holder	EC-ION510/01S	35619-20
Temperature Probe for pH/Ion 510 bench meter, 1m cable length	EC-PH5-TEMB01P	35613-05
110/120VAC power adapter, 50/60 Hz	EC-120-ADA	35615-07
220/230VAC power adapter, 50/60 Hz	EC-220-ADA	35615-08

### 8.4.2 pH Buffers/Sachets, Reference Electrolyte & Others

To order some accessories, send the part name and number to our authorized distributor.

Item Description	Eutech Instruments Order Code No.	Oakton Instruments Order Code No.
pH 4.01 Buffer Solution (480 ml bottle) (1 pint)	EC-BU-4BT	00654-00
pH 7.00 Buffer Solution (480 ml bottle) (1 pint)	EC-BU-7BT	00654-04
pH 10.01 Buffer Solution (480 ml bottle) (1 pint)	EC-BU-10BT	00654-08
pH 4.01 Buffer Sachets (20 ml x 20 pcs. per box)	EC-BU-4BS	35653-01
pH 7.00 Buffer Sachets (20 ml x 20 pcs. per box)	EC-BU-7BS	35653-02
pH 10.01 Buffer Sachets (20 ml x 20 pcs. per box)	EC-BU-10BS	35653-03
Reference Electrolyte (KCl with Ag/AgCl) (480 ml bottle) (1 pint)	EC-RE001	05992-47 (125 ml)
Reference Electrolyte (4MKCl) for Calomel (Hg/ Hg <sub>2</sub> Cl <sub>2</sub> ) electrodes & other specialty electrodes (1 pint)	EC-RE002	05992-48 (125 ml)
Storage Solution for pH Electrode (480 ml bottle) (1 pint)	EC-RE005	00653-04
Protein Cleaning Solution (480 ml bottle) (1 pint)	EC-DPC-BT	00653-06

### 8.4.3 Replacement Electrodes for pH/ ION 510 meters

All electrodes are supplied with 1m cable length and BNC connector.

Item Description	Eutech Instruments Order Code No.	Oakton Instruments Order Code No.
General purpose, Epoxy-body double junction pH Combination Electrode, 12 X 110 mm, 1m cable length	EC-FC72522-01B	35805-05
General purpose, Epoxy-body "3-in-1" pH/Temp. Combination Electrode, 12 X 110 mm, 1m cable length	EC-FC73529-01B	35811-71
Glass body Refillable pH Combination Electrode: Annular ceramic reference junction with protective sensor guard, 1 m cable length	EC-FG73504-01B	05997-10
General Purpose Epoxy-body double junction ORP Electrode, 12 X 110 mm, 1m cable length	EC-FC79602-01B	35805-15

#### 8.4.4 Ion Selective Electrodes (ISE)

---

Ask our distributors for more details regarding ISE and its standard solutions. The table below lists the range of electrodes available. All ISE are supplied with 1m cable length and BNC connector.

Ion	Ion
Ammonia (NH <sub>3</sub> )	Iodide (I <sup>-</sup> )
Ammonium (NH <sub>4</sub> <sup>+</sup> )	Lead (Pb <sup>+2</sup> )
Bromide (Br <sup>-</sup> )	Lithium (Li <sup>+</sup> )
Cadmium (Cd <sup>+2</sup> )	Nitrate (NO <sub>3</sub> <sup>-</sup> )
Calcium (Ca <sup>+2</sup> )	Nitrogen Oxide (NO <sub>x</sub> )
Carbon Dioxide (CO <sub>2</sub> )	Perchlorate (ClO <sub>4</sub> <sup>-</sup> )
Chloride (Cl <sup>-</sup> )	Potassium (K <sup>+</sup> )
Copper (Cu <sup>+2</sup> )	Silver / Sulfide (Ag <sup>+</sup> / S <sup>-2</sup> )
Cyanide (CN <sup>-</sup> )	Sodium (Na <sup>+</sup> )
Fluoride (F <sup>-</sup> )	Surfactant (X <sup>+</sup> , X <sup>-</sup> )
Fluoroborate (BF <sub>4</sub> <sup>-</sup> )	Water Hardness

## 8.5 Specifications

Description		pH 510	Ion 510
pH Range	0.00 to 14.00 pH	✓	✓
Resolution	0.01 pH	✓	✓
Accuracy	± 0.01 pH + 1 count	✓	✓
Ion Concentration Range	0.01 to 1999 ppm		✓ (± 500mV input)
Resolution	0.01 pm (0.01 to 0.99 ppm); 0.1 ppm (1.0 to 199.9 ppm); 1 ppm (200 to 1999 ppm)		✓
Accuracy	±0.5% Full Scale for mono-valent ions ±1.0 % Full Scale for di-valent ions		✓
mV Range	Yes	✓ ± 1999 mV	✓ ± 500mV(Absolute) ±1999mV( Relative)
Resolution	0.1 mV (± 199.9 mV), 1 mV beyond ± 200 mV	✓	✓
Accuracy	± 0.2 mV (± 199.9 mV), ± 2 mV beyond ± 200 mV	✓	✓
Calibration Offset Adjustment	Up to ±150 mV	✓	✓
Temperature Range	0.0 to 100.0 °C	✓	✓
Resolution	0.1 °C	✓	✓
Accuracy	± 0.3 °C	✓	✓
Temperature Compensation	Automatic / Manual (0 to 100 °C)	✓	✓
No. of pH Calibration Points	Up to 5 points with Auto-buffer recognition	✓	✓
pH Buffer Calibration Options	USA : pH1.68, 4.01, 7.00, 10.01,12.45 NIST: pH1.68, 4.01, 6.86, 9.18 ,12.45	✓	✓
No. of Ion Calibration Points	Up to 3 points (minimum 2 points)		✓
Ion Calibration Options	0.1, 1.0, 10.0, 100.0 or 1000.0 ppm		✓
Min. & Max. Slope during Calibration	15 mV/decade to 90 mV/decade		✓
Temperature Calibration	Offset in 0.1 °C increments; Offset range: ± 5 °C	✓	✓
Memory	100 data sets	✓	✓
Hold Function	Yes	✓	✓
Self-diagnostic Messages	Yes	✓	✓
pH Slope and Offset Display	Yes	✓	✓
Inputs	BNC, Phono, Ref. (Half-cell), Ground	✓	✓
Output	Recorder (+/- 2000 mV)	✓	✓
Power Requirements	AC/DC 9V Adapter (110 VAC/220 VAC, 50-60Hz)	✓	✓
Display	Custom Dual LCD (1 x 4 digits, 1 x 3.5 digits, annunciators)	✓	✓
Dimensions / Weight	Meter with electrode holder: 18 x 23 x 6 cm / 1250 g Boxed (meter with electrode holder): 40 x 26 x 9 cm / 1950 g	✓	✓

---

## 9 WARRANTY

---

This bench meter is supplied with a **3-year** warranty from manufacturing defects and electrodes for **6 months** from the date of purchase.

If repair or adjustment is necessary and has not been the result of abuse or misuse within the designated period, please return – freight pre-paid – and correction will be made without charge. Eutech Instruments Pte Ltd/ Oakton Instruments will determine if the product problem is due to deviations or customer misuse.

Out of warranty products will be repaired on a charged basis.

### **Exclusions**

The warranty on your instrument shall not apply to defects resulting from:

- Improper or inadequate maintenance by customer
- Unauthorized modification or misuse
- Operation outside of the environment specifications of the products

---

## 10 RETURN OF ITEMS

---

Authorization must be obtained from our Customer Service Department or authorized distributor before returning items for any reason. A “Return Goods Authorization” (RGA) form is available through our Authorized Distributor. Please include data regarding the reason the items are to be returned. For your protection, items must be carefully packed to prevent damage in shipment and insured against possible damage or loss. Eutech Instruments/ Oakton Instruments will not be responsible for damage resulting from careless or insufficient packing. A restocking charge will be made on all unauthorized returns.

**NOTE:** Eutech Instruments Pte Ltd/ Oakton Instruments reserves the right to make improvements in design, construction, and appearance of products without notice.



For more information on Eutech Instruments/ Oakton Instruments' products, contact your nearest distributor or visit our website listed below:

<p><b>Oakton Instruments</b> P.O Box 5136, Vernon Hills, IL60061, USA Fax: (1) 847-247-2984 <a href="http://www.4oakton.com">www.4oakton.com</a> <a href="http://www.oaktoninstruments.com">www.oaktoninstruments.com</a></p>	<p><b>Eutech Instruments Pte Ltd</b> Blk 55, Ayer Rajah Crescent, #04-16/24 Singapore 139949 Tel: (65) 6778 6876 Fax: (65) 6773 0836 E-mail: <a href="mailto:marketing@eutechinst.com">marketing@eutechinst.com</a> Web-site: <a href="http://www.eutechinst.com">www.eutechinst.com</a></p>	<p><b>Distributed by:</b></p>
---------------------------------------------------------------------------------------------------------------------------------------------------------------------------------------------------------------------------------------------------	----------------------------------------------------------------------------------------------------------------------------------------------------------------------------------------------------------------------------------------------------------------------------------------------------------------------	-------------------------------