

# Alpha COND 560

Controller  
mS /  $\mu$ S / °C / °F





AQUAfast, Cahn, ionplus, KNIpHE, No Cal, ORION, perpHect, PerpHecT, PerpHecTion, pHISA, pHuture, Pure Water, Sage, Sensing the Future, SensorLink, ROSS, ROSS Ultra, Sure-Flow, Titrator PLUS and TURBO2 are registered trademarks of Thermo Fisher.

1-888-pHAX-ION, A+, All in One, Aplus, AQUAsnap, AssuredAccuracy, AUTO-BAR, AUTO-CAL, AUTO DISPENSER, Auto-ID, AUTO-LOG, AUTO-READ, AUTO-STIR, Auto-Test, BOD AutoEZ, Cable-Free, CERTI-CAL, CISA, DataCOLLECT, DataPLUS, digital LogR, DirectCal, DuraProbe, Environmental Product Authority, Extra Easy/Extra Value, FAST QC, GAP, GLPcal, GLPcheck, GLPdoc, ISEasy, KAP, LabConnect, LogR, Low Maintenance Triode, Minimum Stir Requirement, MSR, NISS, One-Touch, One-Touch Calibration, One-Touch Measurement, Optimum Results, Orion Star, Pentrode, pHuture MMS, pHuture Pentrode, pHuture Quatrode, pHuture Triode, Quatrode, QuiKcheK, rf link, ROSS Resolution, SAOB, SMART AVERAGING, Smart CheK, SMART STABILITY, Stacked, Star Navigator 21, Stat Face, The Enhanced Lab, ThermaSense, Triode, TRIUMpH, Unbreakable pH, Universal Access are trademarks of Thermo Fisher.

Guaranteed Success and The Technical Edge are service marks of Thermo Fisher.

## **Preface**

This manual serves to explain the use of the Alpha COND 560 Controller. The manual functions in two ways, firstly as a step by step guide to help the user operate the instrument. Secondly, it serves as a handy reference guide. This instruction manual is written to cover as many anticipated applications of the Alpha COND 560 Controller. If you have doubts in the use of the instrument, please do not hesitate to contact your nearest Alpha Authorised Distributor.

The information presented in this manual is subject to change without notice as improvements are made, and does not represent a commitment on part of Thermo Scientific.

Thermo Scientific cannot accept any responsibility for damage or malfunction of the unit due to improper use of the instrument.

Copyright © 2009

All rights reserved

## **TABLE OF CONTENTS**

<b>1</b>	<b>INTRODUCTION</b>	<b>1</b>
1.1	Before You Begin.....	1
1.2	Intended Use .....	1
1.3	Safety Instructions .....	2
1.4	Taking Out of Service / Correct Disposal of the Unit.....	2
<b>2</b>	<b>GETTING STARTED</b>	<b>3</b>
2.1	Description of Instrument.....	3
2.2	Measurement System .....	4
2.3	Connecting Peripherals .....	5
2.4	Installation .....	8
2.5	Display & Keypad .....	10
<b>3</b>	<b>OPERATION</b>	<b>13</b>
3.1	Measurement mode.....	13
3.2	Menu Overview.....	14
<b>4</b>	<b>CALIBRATION MODE</b>	<b>15</b>
4.1	About Calibration .....	15
4.2	Calibration.....	16
<b>5</b>	<b>SETUP MODE</b>	<b>18</b>
5.1	Enter Setup mode.....	18
5.2	Temperature Coefficient Settings.....	19
5.3	Temperature Settings .....	20
5.4	Relay 1/Relay 2 Settings.....	22
5.5	Controller Settings .....	24
5.6	Measuring Range Settings.....	26
5.7	Configuration Settings.....	27
5.8	Viewing Electrode Properties.....	30
<b>6</b>	<b>TECHNICAL SPECIFICATIONS</b>	<b>31</b>
<b>7</b>	<b>LIST OF ACCESSORIES</b>	<b>34</b>
7.1	Thermo Scientific Order Codes.....	34
7.2	Eutech Instruments Order Code .....	34
<b>8</b>	<b>TROUBLESHOOTING</b>	<b>35</b>
<b>9</b>	<b>GENERAL INFORMATION</b>	<b>36</b>
9.1	Warranty .....	36
9.2	Return of Goods.....	36
9.3	Guidelines for Returning Unit for Repair .....	36
9.4	Maintenance and Cleaning .....	37
<b>10</b>	<b>APPENDICES</b>	<b>38</b>
10.1	Appendix 2 Conductivity of various aqueous solutions .....	38
10.2	Appendix 2 Graphical Representation of the Function of Hysteresis ....	39

10.3 Appendix 3 General Instructions Concerning Controller Setting ..... 40  
10.4 Appendix 4 - Abbreviations Used in LCD..... 41

# 1 INTRODUCTION

## 1.1 Before You Begin

Thank you for purchasing the Alpha COND 560 Controller.

The construction of the Alpha COND 560 Controller employs leading edge technology and complies with safety regulations currently in force. Notwithstanding this, improper use could lead to hazards for the user or a third-party, and/or adverse effects on the plant or other equipment. Therefore, the operating instructions must be read and understood by the persons involved before working with the Conductivity Controller.

The instruction manual must always be stored close at hand, in a place accessible to all people working with the Conductivity Controller.

If you have questions, which are not or insufficiently answered in this instruction manual, please contact your authorized supplier. They will be glad to assist you.

## 1.2 Intended Use

Alpha COND 560 Controllers are intended solely for Conductivity and temperature measurement, as described in this instruction manual.

Any other use, or use not mentioned here, that is incompatible with the technical specifications is deemed inappropriate. The operator is solely responsible for any damage arising from such use.

Other prerequisites for appropriate use include:

- Comply with the instructions, notes and requirements set out in this instruction manual.
- Comply with all local safety regulations concerning safety at work.
- Comply with all information and warnings in the documentation dealing with the products used together with the Conductivity Controller (housing, sensors, etc.).
- Comply with the local environmental and operational conditions.

## 1.3 Safety Instructions



- The Alpha COND 560 Controller should be installed and operated only by personnel familiar with the instrument and who are qualified for such work.
- A defective Conductivity Controller must neither be installed nor put into service.
- The Alpha COND 560 must only be operated under the specified operating conditions (see section 6).
- The Alpha COND 560 must not be repaired by the customer.
- No modifications to the Alpha COND 560 are allowed. The manufacturer/supplier accepts no responsibility for damage caused by unauthorized modifications. The risk is borne entirely by the user.

## 1.4 Taking Out of Service / Correct Disposal of the Unit

### Taking out of Service

- First disconnect the unit from the power supply and then undo all electrical connections.
- Remove the unit from the wall.

### Correct Disposal of the Instrument

When the Alpha COND 560 is permanently taken out of service, obey the local environmental regulations for correct disposal or send the instrument to your local distributor, they will take care of proper disposal.

## 2 GETTING STARTED

### 2.1 Description of Instrument

The Eutech Instruments' **Alpha CON 560 Controller** is used for measuring conductivity and temperature values. The controller can be used for applications such as water treatment and controlling, galvanic-decontamination, chemical processing, food processing, clean or wastewater control and neutralization processes.

The controller has many user-friendly and safety features which include:

- Push-button keypad for calibration and setup
- Built-in non-volatile memory to ensure that calibration and other information are not erased if power supply fails
- Menu-driven program that simplifies setup
- Automatic temperature compensation (ATC)
- Manual temperature compensation setting without the ATC probe, with independent setting for calibration and process temperature
- Large dual display LCD for easy reading with clear multiple annunciators, operational mode indicators and error indicators
- Two switching contacts as set-point relays
- Limit (on/off) control mode
- Separately adjustable high and low set-point hysteresis (dead bands) to prevent chattering of relays around the set points
- 0 to 2000 seconds time delay adjustment on all relays – minimizes false alarms
- Backlight LCD display

## 2.2 Measurement System

A typical measurement system consists of:

- A conductivity process controller
- A conductivity sensor with integrated or separate Pt100/Pt1000 temperature sensor
- An appropriate measurement cable
- An immersion, flow or process assembly
- A final control element such as pump or valve

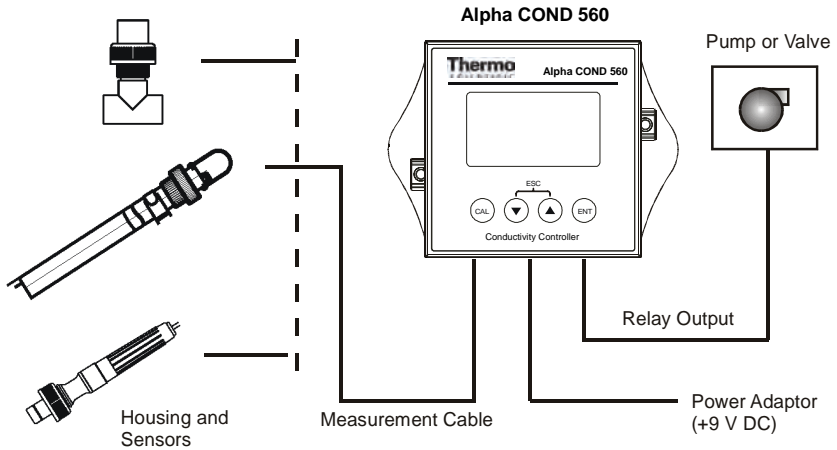

## 2.3 Connecting Peripherals

### 2.3.1 Connection Terminals

#### Remove Back Cover:

Remove the screws from the four corners at the back of the conductivity controller. Remove the back cover. The connectors are exposed on the back PCBA as shown in the Figure 1 below.

#### Connectors:

- J11 – 24V DC power connector
- J8 – 9V DC power connector (1.2mm diameter)
- J9 – Relay connections
- J10 - Conductivity electrode & Temperature probe connections (wiring has to be done in the detachable connector)

#### J11 Connections

1. +ve
2. Gnd

#### J10 Connections

1. CON Low Current
2. CON Low Voltage
3. CON High Voltage
4. CON High Current
5. Pt 100 Compensate
6. Pt 100 Sense
7. Pt 100 GND
8. (No connection)

#### J9 Connections

Relay 1 & 2

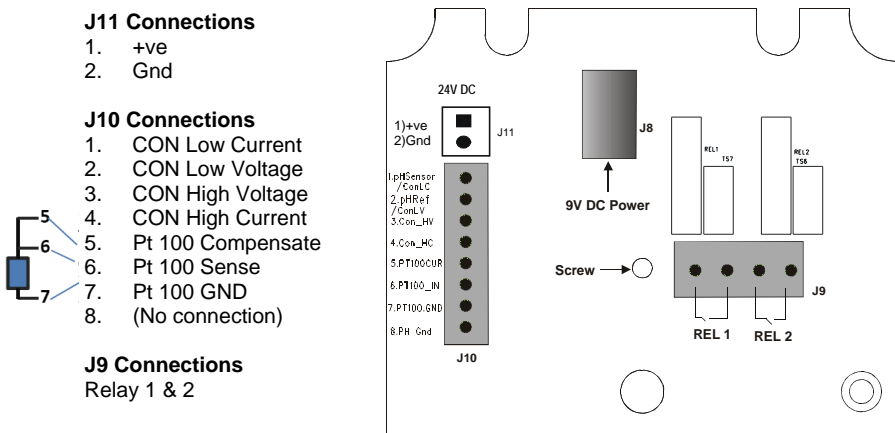

Figure 1: Outer Side of Back PCBA

### 2.3.2 Switching Between PT100 & PT1000 Temperature Sensors

The controller supports both Pt100 & Pt1000 (2-wire or 3-wire) temperature sensors. The default factory setting is Pt100. If you need to use Pt1000 temperature sensor, you have to change the jumper setting (J7) as described below.

#### Remove Back Cover:

Remove screws from the four corners at the back of the conductivity controller. Remove the back cover.

#### Remove Back PCBA:

Remove the screw located center of the back PCBA (Figure 1). Detach the back PCBA from the controller. Turn over the back PCBA. Locate J7 jumper on the inner side of the back PCBA as shown in **figure 2** below.

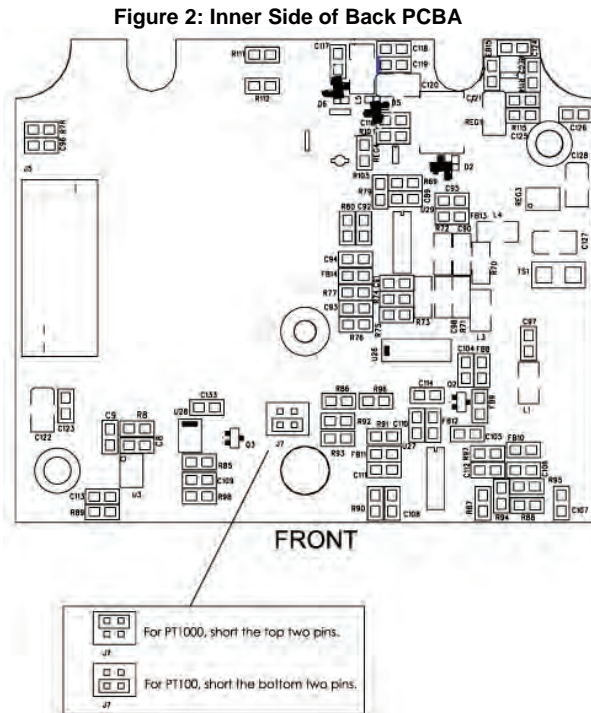

#### Set Jumper J7:

Set the J7 jumper to required sensor (Pt100 or Pt1000) type

### 2.3.3 Connecting Conductivity Electrode

Any industrial conductivity probe (2-cell or 4-cell) can be connected to the conductivity controller.

#### **2-Cell Conductivity Probe:**

1. Short Pin 1 & 2 of J10 connector using a jumper wire.
2. Connect CON low input wire (white) to Pin 2 of J10 connector.
3. Connect CON high input wire (black) to Pin 3 of J10 connector.
4. Short Pin 3 & 4 of J10 connector using a jumper wire.

#### **4-Cell Conductivity Probe:**

5. Connect CON low input wire (black) to Pin 1 of J10 connector
6. Connect CON low input wire (white) to Pin 2 of J10 connector.
7. Connect CON high input wire (orange) to Pin 3 of J10 connector.
8. Connect CON high input wire (blue) to Pin 4 of J10 connector.

### 2.3.4 Connecting Temperature Probe

For Automatic Temperature Compensated (ATC) conductivity readings, an in-built temperature sensor is usually integrated with industrial conductivity probes. Alternatively, a separate 100 $\Omega$  Pt RTD temperature probe (2-wire or 3-wire) can be connected to the controller.

#### **3-Wire Probe:**

1. Connect PT100 compensate wire to Pin 5 of J10 connector.
2. Connect PT100 sense wire to Pin 6 of J10 connector.
3. Connect PT100 GND wire to Pin 7 of J10 connector.

#### **2-Wire Probe:**

4. Short Pin 5 & 6 of J10 connector using a jumper wire.
5. Connect PT100 sense wire to Pin 6 of J10 connector.
6. Connect PT100 GND wire to Pin 7 of J10 connector.

## 2.4 Installation

### 2.4.1 Mechanical Dimensions

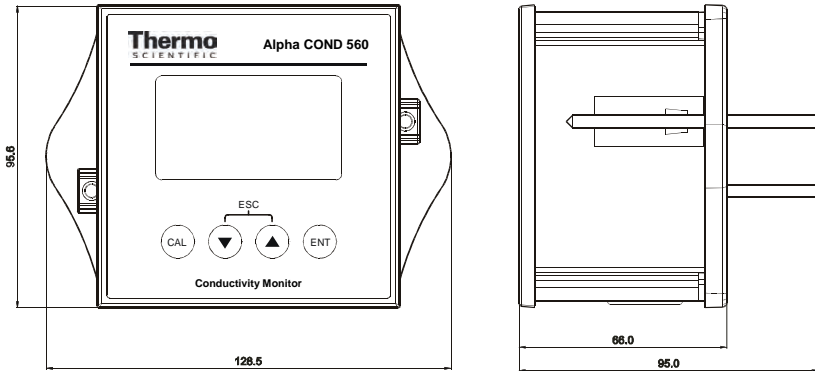

### 2.4.2 Wall Mount

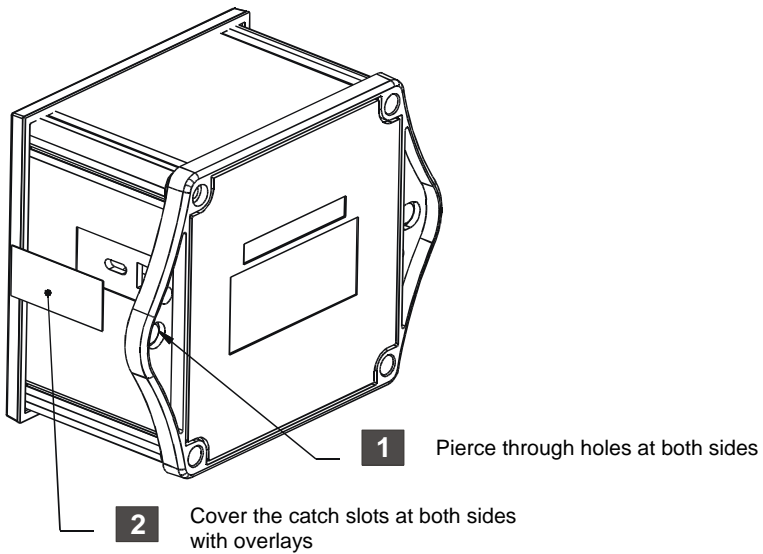

### 2.4.3 Panel Mount

**1** Prepare panel cut-out of  
**92.0 mm X 92.0 mm**

**2** Remove back cover of  
pH Monitor and slide it  
through panel cut-out

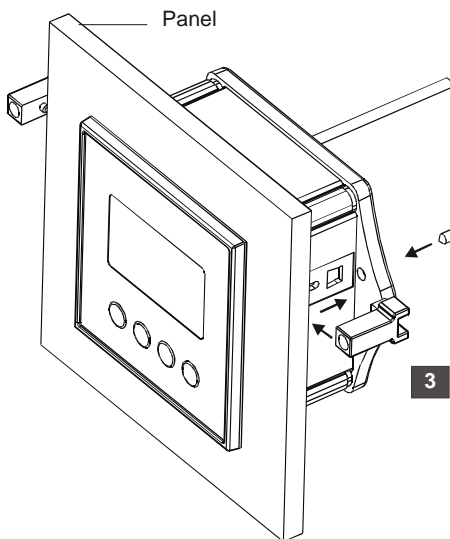
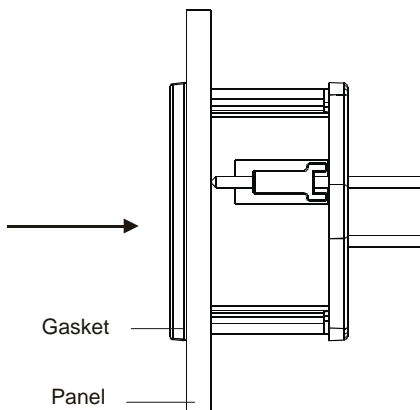

**4** Insert threaded rods through catch  
until pH Meter is held against panel

**3** Attach catch to both sides  
of pH Meter

## 2.5 Display & Keypad

### 2.5.1 Display Overview

The Liquid Crystal Display (LCD) of **Alpha COND 560** conductivity controller has two alpha-numerical displays (Upper and a Lower).

- **Upper display:** Measured conductivity value is displayed when the controller is in normal operation (measurement) mode.
- **Lower display:** Measured temperature value is displayed when the controller is in normal operation (measurement) mode. In conductivity calibration mode, measured conductivity values are displayed here.

The two displays indicate function names, options & settings in Setup mode. Refer 'Appendix 4 - Abbreviations Used in LCD' for more details.

The LCD also consists of various mode indicators, status annunciators and unit of measurement indicators.

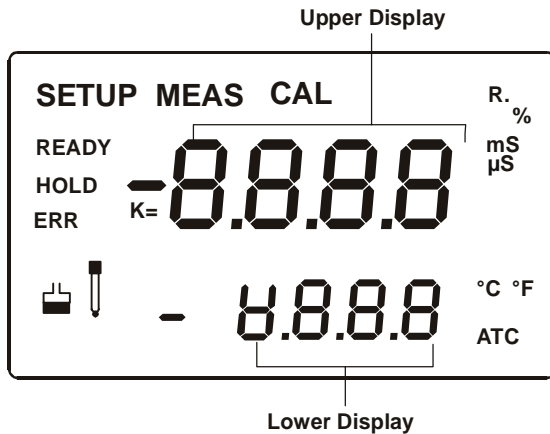

## Mode Indicators

**MEAS** Measurement mode (*Refer Section 3.1*)

**SETUP** Setup mode (*Refer Section 4.1*)

**CAL** Calibration mode (*Refer Section 4*)

## Status Annunciators

**READY** Appears when the reading is stable

**HOLD** Appears in Setup mode and Calibration mode to indicate that the relay function is frozen

**ATC** Appears when Automatic Temperature Compensation (ATC) is enabled. Not visible when Manual Temperature Compensation (MTC) is enabled. Flashes if the temperature probe is faulty in its ATC mode. (*Refer Section 5.3*)

**ERR** Appears when an error occurs



Electrode annunciator. Blinks during calibration error (*Refer Section 4.2*)



Buffer annunciator. Appears in calibration mode (*Refer Section 4.2*)

**K**

Cell Constant (*Refer Section 4.2*)

## Units of Measurement Indicators

**mS** Conductivity in Milli Siemens

**μS** Conductivity in Micro Siemens

**R.** Line Resistance in Ohms (*Refer Section 5.7*)

**%** Temperature Coefficient (*Refer Section 5.2*)

**°C** Temperature in Celsius (*Refer Section 5.3*)

**°F** Temperature in Fahrenheit (*Refer Section 5.3*)

## 2.5.2 Key Functions

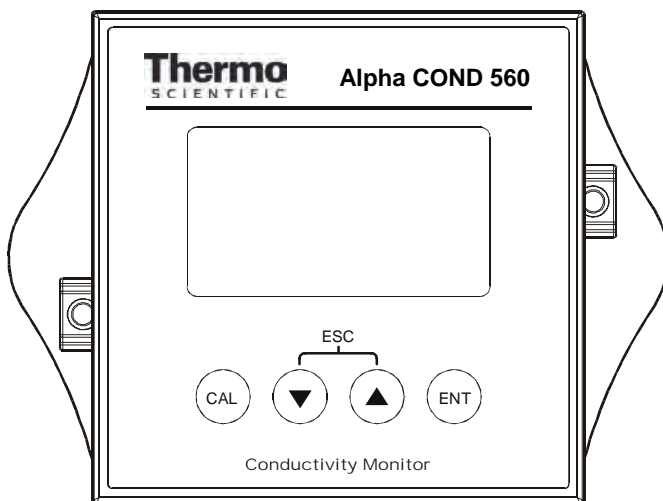

Key	Description
	Enter Calibration mode
	Enter Setup mode Access sub screens (parameters) within a group of settings in Setup mode Confirm (save) setup parameters and numerical values Start/Confirm calibration in Calibration mode.
	Select a group of settings in Setup mode. Select parameters and increment/decrement numerical values in Setup and Calibration modes.
	(When pressed continuously, speed of value increment/decrement increases) Returns to Measurement mode when both keys are pressed simultaneously.

## 3 OPERATION

### 3.1 Measurement mode

When the conductivity controller is powered on, the display shows all the LCD segments briefly, and then automatically enters into the **measurement mode**.



The mode indicator '**MEAS**' at the top of the display indicates that the conductivity controller is in measurement mode. The upper alpha-numerical display shows the measured conductivity value, while the lower display shows the temperature value.

The controller has six selectable measuring ranges. The unit of measurement and resolution of the conductivity reading depend on the selected measuring range. If the controller reads a conductivity reading beyond the selected measuring range, the display shows 'Or' (over range) error indicator.

**NOTE:** To guarantee accurate readings, the measuring system (the conductivity controller and the sensor) must be calibrated regularly.

From measurement mode you can access:

- **Calibration mode** (by pressing **CAL** key)
- **Setup mode** (by pressing **ENT** key)

For more details, refer section 4 for Calibration mode and section 5 for Setup mode.)

## 3.2 Menu Overview

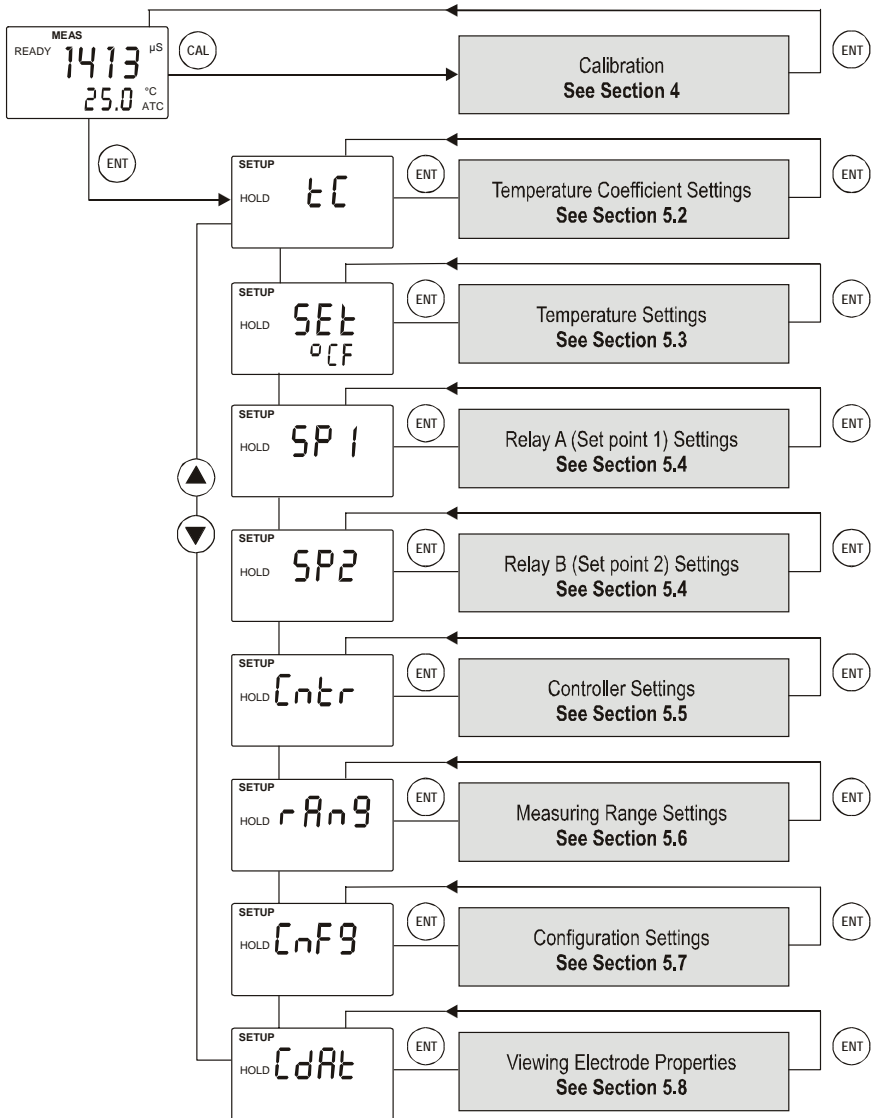

## 4 CALIBRATION MODE

### 4.1 About Calibration

Calibration should be carried out each time a new electrode is attached to the controller or when you suspect that the controller/electrode is out of calibration. The controller allows you to perform temperature calibration and conductivity calibration.

#### **About Temperature Calibration**

It is important to ensure that temperature calibration is carried out prior to conductivity calibration since temperature readings affect the accuracy of conductivity measurements. It is recommended that temperature calibration should be carried out only if the temperature value displayed on the controller is different from that of a calibrated thermometer. A temperature offset calibration of  $\pm 10\text{ }^{\circ}\text{C}/\pm 18\text{ }^{\circ}\text{F}$  from the default reading is allowed. Once a temperature calibration is performed, conductivity calibration should be carried out to ensure the accuracy of conductivity measurements.

#### **About Measuring Ranges & Conductivity Calibration**

The controller has six selectable conductivity measuring ranges. You can only calibrate one-point in the measuring range that you have selected for your process application. You have to recalibrate the controller every time you change the measuring range since the calibration data of the controller will be reset every time a new measuring range is selected.

#### **About Conductivity Calibration**

During conductivity calibration, the controller allows a calibration window of  $\pm 40\%$  from the measured default reading of the calibration standard. The minimum allowable calibration point is 10% of the full scale reading of the measuring range selected.

For best results, select a standard conductivity solution close to the sample value you are measuring.

## 4.2 Calibration

The controller requires one-point calibration. Conductivity calibration is always carried out in the specific measuring range selected for the controller. Make sure, the controller is set to desired measuring range before you enter calibration mode (Refer Section 5.6 for selecting measuring ranges).

Select a suitable standard conductivity solution so that its conductivity value is within 10% to 100% of the full scale of the selected measuring range of the controller. (For better accuracy, select the calibration standard to be nearly 50% of the full scale of the measuring range selected.) Prepare calibration standard solution in two beakers – one for rinsing and the other for calibration. Prepare separate de-ionized water for electrode rinsing.

All new calibration values will automatically override existing calibration data. If you wish to abort the calibration, press ▲ and ▼ keys simultaneously and the controller reverts to measurement mode and the controller will revert to previous calibration data.

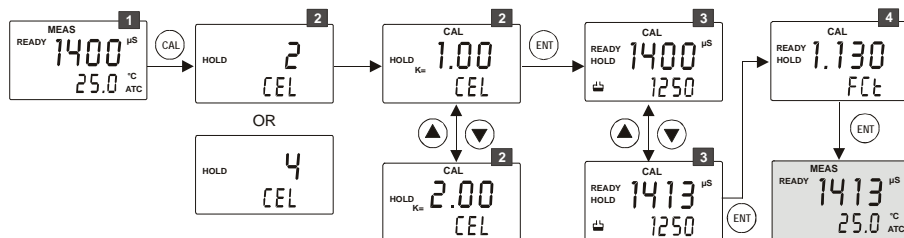

- 1** From measurement mode press CAL key to enter calibration mode.
- 2** The display briefly shows the cell type (“2 CELL” or “4 CELL”) to which the controller is configured (Refer section 5.7 for cell type settings)  
Next, the last configured cell constant (k) is displayed in the upper display. Use ▲ or ▼ keys to adjust the cell constant to match the cell constant of the conductivity probe. Adjustable range is 0.10 to 10.0. Press ENT key to confirm the new cell constant value.  
Rinse the electrode in de-ionized water and then rinse with the calibration standard. Immerse the probe in calibration standard solution intended for calibration and swirl gently to create a homogenous sample. Make sure there are no any air-bubbles trapped in the sensor.
- 3** The upper display shows the currently measured conductivity value of the solution based on last calibration (if any). The lower display shows

uncalibrated (default) reading of the solution. The buffer annunciator appears in LCD. The 'READY' annunciator appears when the reading is stable.

Once the reading stabilizes press the ▲ or ▼ key to adjust the upper display value to that of the standard solution. Press the ENT key to accept the value.

**NOTES:** The acceptable calibration window is  $\pm 40\%$  of the displayed (default) value. For example, if the display is 1000  $\mu\text{S}$ , the values to which it can be adjusted is 600 to 1400  $\mu\text{S}$ .

If the conductivity reading of the solution is not within 10% to 100% of the full scale of the selected measuring range, calibration error occurs; LCD displays "ERR" and flash electrode annunciator.

If the conductivity reading of the solution is beyond the selected measuring range, calibration error occurs; LCD displays "Or" (over range), "ERR" and flashes electrode annunciator.

If calibration error occurs, exit form calibration mode by pressing ▲ and ▼ keys simultaneously.

4

Calibration is completed. The display shows the calibration factor (FCt). This serves as an indication of the effectiveness of the sensor which will degrade with time and usage. An effective sensor should have a calibration factor of 0.60 to 1.40

Press ENT key to return to measurement mode.

#### NOTES:

- If you use a 2-cell conductivity sensor, make sure that the pin 1 and 2 are shorted and pin 3 and 4 are shorted on the J10 connector. (Refer section 2 for more details)
- When calibrating with manual temperature compensation, the controller automatically changes from the preset process temperature to the calibration temperature. After leaving the Calibration mode, the controller switches back to the process temperature (for setting the calibration temperature and the process temperature, see section 5.3)

**WARNING:** If you change the measuring range of the controller after calibration is done, the controller will reset back to its factory default calibration.

## 5 SETUP MODE

### 5.1 Enter Setup mode

The setup mode allows you to customize the settings of the conductivity controller to suite your requirements. While in measurement mode, **press the ENT key** to access setup mode. LCD shows 'SETUP' mode indicator and the first page of setup (**rAng** – Range settings). **Press ▲ or ▼ key** to access other pages of the setup mode.

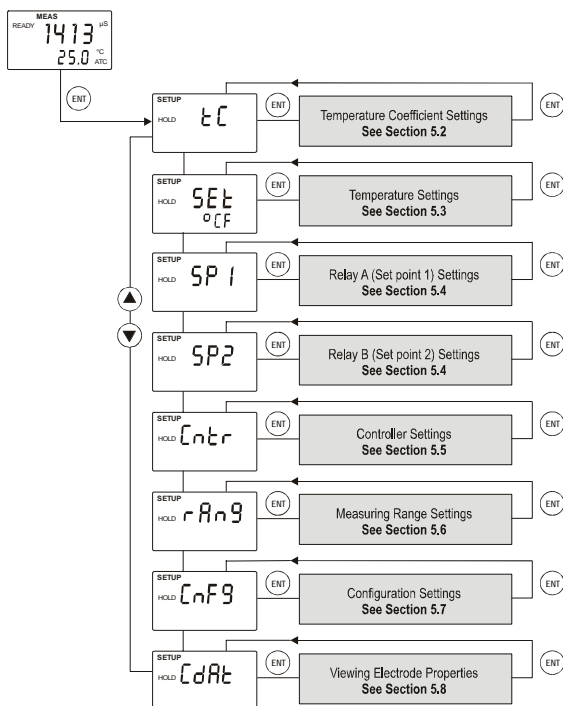

#### NOTES:

- To exit setup mode at any time **press ▲ and ▼ keys simultaneously** (escape). The controller returns to the measurement mode
- If you do not press any key for 2.5 minutes, the controller automatically exits from the setup mode.

## 5.2 Temperature Coefficient Settings

Setting the temperature coefficient to match your process/calibration liquids allows controller to achieve conductivity readings with higher accuracy.

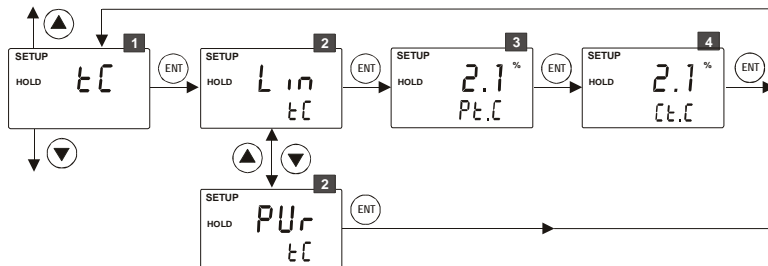

**1** From measurement mode **press ENT key** to enter setup mode as described in section 5.1. The LCD shows the first screen of setup mode (rAng). **Press ▲ or ▼ key** to select temperature coefficient settings screen (tC).

**Press ENT key** to access temperature coefficient settings (tC).

**2** **Select type of temperature coefficient:** The upper display shows the last configured temperature coefficient type (Lin or Pur). **Press ▲ or ▼ key** to select the desired type based on type of your process liquid.

**PUr :** **Pure water temperature coefficient:** Select this if your process liquid is pure water or ultra pure water.

**Lin :** **Linear temperature coefficient:** Select this for all other process liquids

**Press ENT key** to confirm your selection.

**If PUr was selected:** The controller reverts back to tC screen

**If Lin was selected:**

**3** **Select temperature coefficient for process liquid:** The lower display shows 'P.t.C'. The upper display shows last configured temperature coefficient for process liquid (if any). The default value is 2.1%. **Press ▲ or ▼ key** to select the desired value. Allowable range: 0 to 10%.

**Press ENT key** to confirm your value.

**4** **Select temperature coefficient for calibration liquid:** The lower display shows 'C.t.C'. The upper display shows last configured temperature coefficient for calibration liquid (if any). The default value is 2.1%. **Press ▲ or ▼ key** to select the desired value. Allowable range: 0 to 10%. **Press ENT key** to confirm your value. The controller reverts to tC screen.

Press ▲ or ▼ key to access other setup screens or press ▲ and ▼ key simultaneously (escape) to return to measurement mode.

## 5.3 Temperature Settings

### Automatic Temperature Compensation (ATC):

The conductivity value of a sample is affected by temperature. Use ATC feature of the controller to compensate for conductivity changes when the temperature of the sample or process liquid fluctuates. Connect a separate temperature probe (Pt100/pt1000) to the controller if an integrated conductivity/Temperature probe is not available.

### Manual Temperature Compensation (MTC):

Set the controller to MTC (disable ATC) when the temperature of sample or process liquid is constant and a temperature probe is not available. If you disable ATC, the controller allows you to set your process temperature (P.°C) and calibration temperature (C.°C). This allows calibration at a different temperature other than the process temperature. Example: Setting calibration temperature of 25°C lets you calibrate using standard solutions at 25°C, even if your process temperature is different from 25°C.

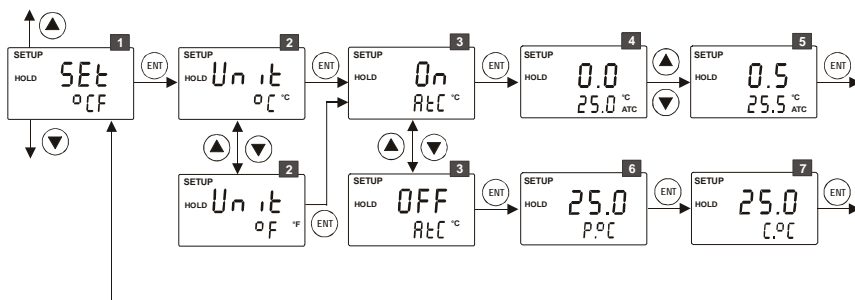

- 1 From measurement mode **press ENT key** to enter setup mode as described in section 5.1. The LCD shows the first screen of setup mode (rAng). **Press ▲ or ▼ key** to select Temperature settings screen (SET °CF).

**Press ENT key** to access temperature settings (SET °CF).

- 2 **Selecting unit of measurement for temperature:** The upper display shows 'Unit' and the lower display shows the last configured unit of measurement for temperature.

**Press ▲ or ▼ key** to select the desired units for temperature (°C or °F). **Press ENT key** to confirm your selection.

- 3 **Enable/disable ATC:** The lower display shows 'AtC' and the upper display shows the last configured ATC selection ('On' or 'OFF').

Press **▲** or **▼** key to enable (**ATC On**) or disable (**ATC OFF**) automatic temperature compensation. Press **ENT** key to confirm your selection.

**If ATC enabled (ATC On):**

- 4** **Selecting temperature offset:** The upper display shows the last configured temperature offset value (if any), otherwise the default is zero. The lower display shows currently measured temperature reading (including last configured offset value). LCD shows '**ATC**' annunciator in lower-right corner.

Place a thermometer, which is known to be accurate, in your sample or process liquid. Make sure your temperature probe is placed in the same liquid. Compare the stabilized temperature reading displayed on the controller with the thermometer. If there is a difference between the two readings (offset), you can adjust the reading of the controller. Press **▲** or **▼** key to adjust the lower display to the correct temperature value.

- 5** As the lower display value changes, the controller adjust the upper display reading automatically to suit the new offset value. Up to  $\pm 10$  °C /  $\pm 18$  °F offset is allowed.

Press **ENT** key to confirm the value. The controller reverts to **SET °CF** screen.

**If ATC disabled (ATC OFF):**

- 6** **Setting process temperature:** The lower display shows '**P.°C**' and the upper display shows the last configured process temperature. Press **▲** or **▼** key to adjust the upper display to desired process temperature. Allowable range:  $-10.0$  to  $125.0$ °C /  $14.0$  to  $257.0$ °F.

Press **ENT** key to confirm the process temperature.

- 7** **Setting calibration temperature:** The lower display shows '**C.°C**' and the upper display shows the last configured calibration temperature. Press **▲** or **▼** key to adjust the upper display to desired calibration temperature. Allowable range:  $-10.0$  to  $125.0$ °C /  $14.0$  to  $257.0$ °F.

Press **ENT** key to confirm the calibration temperature. The controller reverts to **SET °CF** screen.

Press **▲** or **▼** key to access other setup screens or press **▲** and **▼** key simultaneously (escape) to return to measurement mode.

To exit from any intermediate steps, press **▲** and **▼** keys simultaneously (escape). The controller returns to the first screen of temperature settings **SET °CF**.

## 5.4 Relay 1/Relay 2 Settings

**NOTE:** If controller type is set to 'OFF' (Refer section 5.5 for controller settings), the 'Relay 1/Relay 2 Setting' is not available.

The SP1 settings determine the operating parameters for Relay 1; while SP2 settings define the operating parameters for Relay 2. Since these two settings have identical setup parameters, only SP1 is described here.

Note that when you change measuring range of the controller, the values you have set for SP1 & SP2 will not be affected. However, the unit of measurement & resolution displayed in LCD for SP1 & SP2 will change according to the newly selected measuring range.

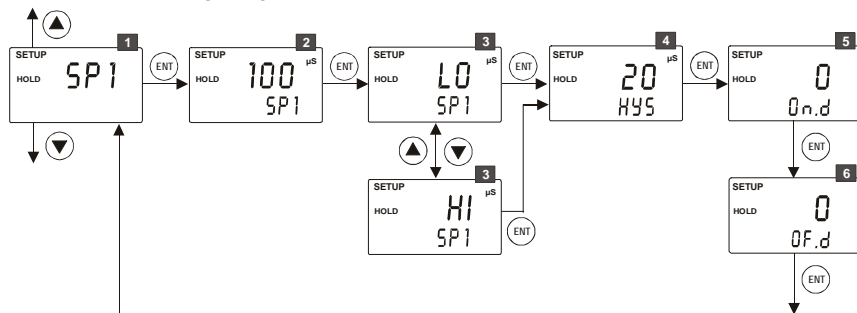

**1** From measurement mode **press ENT key** to enter setup mode as described in section 5.1. The LCD shows the first screen of setup mode (**rAng**). **Press ▲ or ▼ key** to select relay 1 (Set point 1) settings screen (**SP1**).

**Press ENT key** to access relay 1 settings (**SP1**).

**2** **Setting set point value:** The upper display shows the last configured set point value, otherwise the default value 100 μS. **Press ▲ or ▼ key** to enter the value for set point 1, at which control function of the conductivity controller should activate. **Press ENT key** to confirm your set point value.

**3** **Select relay function:** The upper display shows the last configured relay function (**LO** = Low or **HI**=High). **Press ▲ or ▼ key** to select the desired function.

**Press ENT key** to confirm your selection.

**NOTE:** This parameter lets you choose the relay function. Select 'LO' to activate the relay when the conductivity reading undershoots the set point (SP1) or select 'HI' to activate the relay when the conductivity reading overshoots the set point (SP1). SP1 and SP2 can be selected as 'LO/LO', 'LO/HI', 'HI/LO', or 'HI/HI'.

**4** **Setting hysteresis value:** The lower display shows 'HYS'. The upper display shows the last configured value, otherwise the default value 20  $\mu$ S. **Press ▲ or ▼ key** to enter the hysteresis value for set point 1. Allowable range: 0 to 10% of full-scale of the selected measuring range.

**Press ENT key** to confirm your hysteresis value.

**NOTE:** Hysteresis prevents rapid relay contact switching if the conductivity reading is fluctuating near the set point. Refer 'Appendix 2 Graphical Representation of the Function of Hysteresis'.

**5** **Setting on-delay time:** The lower display shows 'On.d'. The upper display shows last configured on-delay value. **Press ▲ or ▼ key** to enter the on-delay time for set point 1. Allowable range: 0 to 2000 seconds. When the conductivity reading is reached the set point 1, the controller delays the relay activation (switch on) by the on-delay time you set here.

**Press ENT key** to confirm your on-delay time.

**6** **Setting off-delay time:** The lower display shows 'OF.d'. The upper display shows last configured off-delay value. **Press ▲ or ▼ key** to enter the off-delay time for set point 1. Allowable range: 0 to 2000 seconds. When the conductivity reading is reached the set point 1 plus hysteresis value, the controller delays the relay deactivation (switch off) by the off-delay time you set here.

**Press ENT key** to confirm your off-delay time. The controller reverts to **SP1** screen.

Press ▲ or ▼ key to access other setup screens or press ▲ and ▼ key simultaneously (escape) to return to measurement mode.

## 5.5 Controller Settings

The controller settings allow you to set the relay type and relay status of the controller.

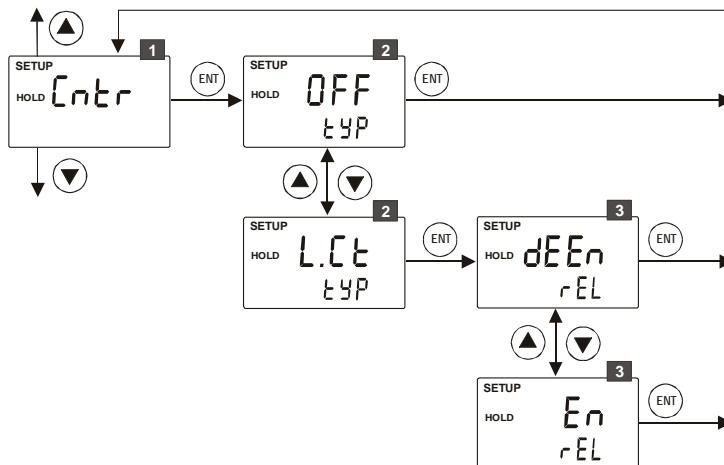

- 1 From measurement mode **press ENT key** to enter setup mode as described in section 5.1. The LCD shows the first screen of setup mode (rAng). **Press ▲ or ▼ key** to select controller settings screen (Ctr).

**Press ENT key** to access controller settings (Ctr).

- 2 **Select the controller type:** The lower display shows 'tyP'. The upper display shows the last configured controller type. ('OFF' or 'L.Ct'). **Press ▲ or ▼ key** to select the desired controller type.

**OFF :** **Controller Off**

Selecting 'OFF', the conductivity controller stops functioning as a controller by preventing relay functions. Once the controller type is set to 'OFF', the setup mode does not show you the Relay 1/Relay 2 settings.

**L.Ct:** **Limit value control (Controller On)**

Selecting 'L.Ct', the conductivity controller is set to function as a controller. When the controller type is set to 'L.Ct', the Relay 1/Relay 2 settings are available in the setup mode for you to configure relay operating parameters.

**Press ENT key** to confirm your selection.

**If Controller type was set to Off (OFF):**

The controller reverts to **Cntr** screen.

**If Controller type was set to On (L.Ct):**

**3**

**Select the relay status under Non-Alarm condition:** The lower display shows 'rEL'. The upper display shows the last configured relay status. ('dEEn' or 'En'). **Press ▲ or ▼ key** to select the desired relay status.

**dEEn:** De-energized

**En:** Energized

**Press ENT key** to confirm your selection. The controller reverts to **Cntr** screen.

Press **▲** or **▼** key to access other setup screens or press **▲** and **▼** key simultaneously (escape) to return to measurement mode.



## 5.7 Configuration Settings

Configuration settings let you to enable/disable backlight of the LCD, select between 2-cell & 4-cell and reset the controller to factory defaults.

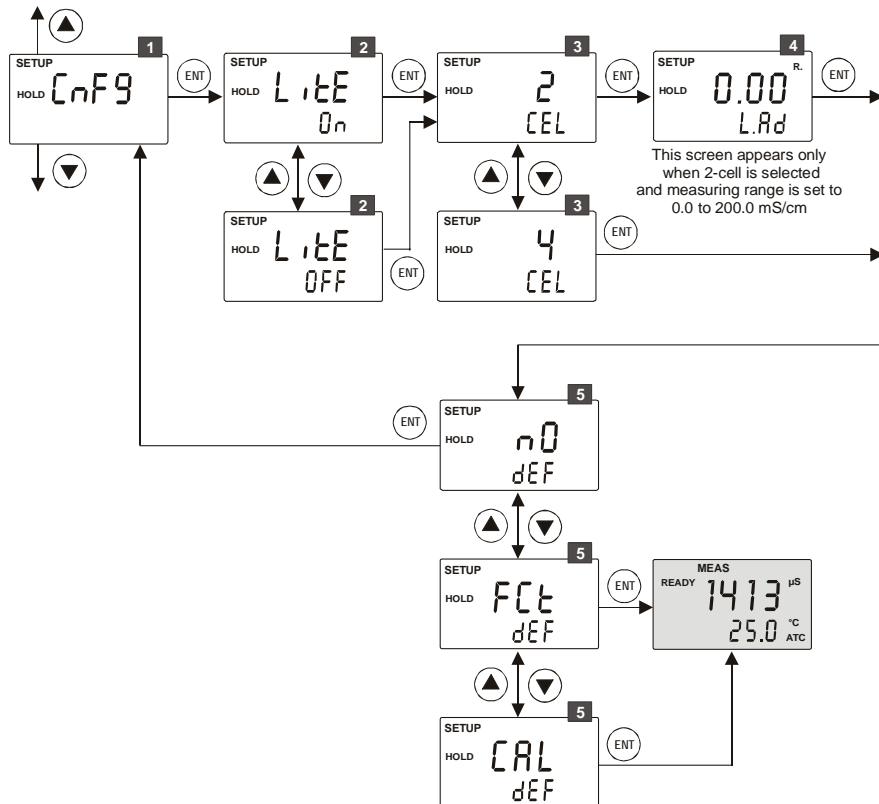

- 1 From measurement mode **press ENT key** to enter setup mode as described in section 5.1. The LCD shows the first screen of setup mode (rAng). **Press ▲ or ▼ key** to select configuration settings screen (Cnfg).

**Press ENT key** to access configuration settings (Cnfg).

- 2 **Enable/disable LCD backlight:** The upper display shows 'LitE'. The lower display shows last configured backlight selection ('On' or 'OFF').

**Press ▲ or ▼ key** to enable (LitE On) or disable (LitE OFF) backlight

of the LCD.

**Press ENT key** to confirm your selection.

**3 Select cell type of the sensor:** The lower display shows 'CEL'. The upper display shows the last configured cell type ('2' or '4').

**Press ▲ or ▼ key** to select the cell type of your conductivity probe.

**Press ENT key** to confirm your selection.

**NOTE:** If you use a 2-cell conductivity sensor, make sure that the pin 1 and 2 are shorted and pin 3 and 4 are shorted on the J10 connector. (Refer section 2 for more details)

**4 Setting line resistance:** The lower display shows 'L.Ad' and the upper display shows the last configured line resistance; otherwise the default is 0.00 R.

**NOTE:** Line resistance of sensor cable constitutes to an error in measurement of high conductivity values. The controller will compensate this error if you specify line resistance value in this setting. The setting is available only if the cell type is set to 2-cell (step 3 above) and the measuring range is selected to '0.0 to 200.0 mS/cm'.

**Press ▲ or ▼ key** to set the line resistance of the sensor cable connected to the controller.

**Press ENT key** to confirm your selection.

**5 Reset to factory defaults:** The display shows 'nO dEF'.

**Press ▲ or ▼ key** to select:

**nO dEF :** Not default reset of the controller. User configured values remain active, when confirmed by pressing ENT key.

**Fct dEF:** Reset all settings of the controller to factory defaults, when confirmed by pressing ENT key.

**CAL dEF:** Reset all calibration settings of the controller to factory defaults, when confirmed by pressing ENT key.

**NOTE:** Refer section 6 for factory/calibration default settings

**Press ENT key** to confirm your selection.

- If 'nO dEF' was selected, the controller reverts to **Cnfg** screen.

**Press ▲ or ▼ key** to access other setup screens or **press ▲ and ▼ key simultaneously** (escape) to return to measurement mode.

- If 'Fct dEF' or 'CAL dEF' was selected, the controller performs the selected reset and returns to measurement mode.

**Press ▲ or ▼ key** to access other setup screens or **press ▲ and ▼ key simultaneously** (escape) to return to measurement mode.

To exit from any intermediate steps, **press ▲ and ▼ keys simultaneously** (escape). The controller returns to the first screen configuration settings (**Cnfg**).

## 5.8 Viewing Electrode Properties

Each time you calibrate the conductivity sensor, the controller re-calculates the calibration factor of the sensor and shown in the LCD at the end of calibration. The setup mode allows you to view the last saved calibration factor and cell constant at any time.

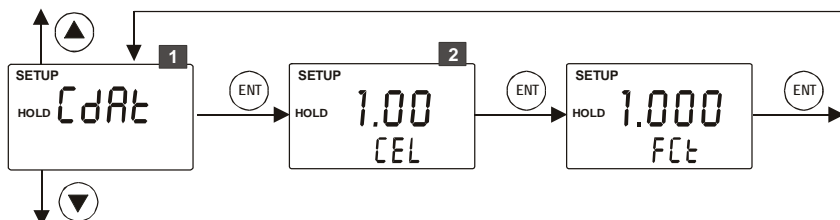

- 1** From measurement mode **press ENT key** to enter setup mode as described in section 5.1. The LCD shows the first screen of setup mode (**rAng**). **Press ▲ or ▼ key** to select viewing electrode properties screen (**CdAt**).

**Press ENT key** to view electrode properties (**CdAt**).

- 2** **Cell constant:** The lower display shows 'CEL' and the upper display shows the last configured cell constant.

**Press ENT key.**

- 3** **Calibration factor:** The lower display shows 'Fct' and the upper display shows the calibration factor based on the last conductivity calibration.

**NOTE:** The upper display shows ' - - ' if the controller has not been calibrated yet or the controller has been reset to factory defaults.

**Press ENT key** to quit from electrode properties screen. The controller reverts to **CdAt** screen.

**Press ▲ or ▼ key** to access other setup screens or **press ▲ and ▼ key simultaneously** (escape) to return to measurement mode.

## 6 TECHNICAL SPECIFICATIONS

### General Specification

#### Conductivity

Measuring Range:	Resolution:
0.000 - 2.000 $\mu\text{S/cm}$	0.001 $\mu\text{S/cm}$
0.00 - 20.00 $\mu\text{S/cm}$	0.01 $\mu\text{S/cm}$
0.0 - 200.0 $\mu\text{S/cm}$	0.1 $\mu\text{S/cm}$
0- 2000 $\mu\text{S/cm}$	1 $\mu\text{S/cm}$
0.00 - 20.00 $\text{mS/cm}$	0.01 $\text{mS/cm}$
0.0 - 200.0 $\text{mS/cm}$	0.1 $\text{mS/cm}$
Relative accuracy	$\pm 1\%$ of full scale reading
System accuracy	The effective measuring range and the total system accuracy depend on the sensor used with the controller. Please refer respective sensor documentation.

#### Temperature

Measuring range	-10.0 to +125.0 $^{\circ}\text{C}$ +14.0 to +257.0 $^{\circ}\text{F}$
Resolution	0.1 $^{\circ}\text{C}$ / 0.1 $^{\circ}\text{F}$
Relative accuracy	$\pm 0.5$ $^{\circ}\text{C}$ / $\pm 1.0$ $^{\circ}\text{F}$
Sensor	2 wire / 3 wire - Pt100 or Pt1000 (Jumper Selectable)
Compensation	Automatic or Manual (reference at 25 $^{\circ}\text{C}$ )

### Calibration

#### Conductivity

Number of calibration points	1 point
Calibration window	$\pm 40\%$ of default reading
Calibration standard solution window	10% to 100% of the selected measuring range

#### Temperature

Offset Adjustment	$\pm 10$ $^{\circ}\text{C}$ / $\pm 18$ $^{\circ}\text{F}$
-------------------	---

### Controller

Output	2 SPST Relays
Relay 1/Relay 2 function (for Set Point 1 (SP1) & Set Point(SP2))	LO (Relay is active when measured value < Set point) HI (Relay is active when measured value > Set point)
Hysteresis window	0% to 10 % of selected measuring range
On-delay & Off-delay time	0 to 2000 seconds

### Display

LCD	7 segments display with symbols for status information
Back light	On/Off selectable

## Electrical Data and Connections

Conductivity Input	Screw Terminal (3.5mm pitch)
Connection terminal	8-pin, 2-pin & 5-pin terminal blocks, DC power connector (1.2mm diameter)

## EMC Specifications

Emission	EN 61 36
Susceptibility	EN 61326

## Other

Power Input	Universal +9 V DC Adaptor and 24V DC Supply
Dimensions (W x H x D)	96mm x 96mm x 66 mm
Weight (Estimated)	210g
Ambient Temp. operating range	0 to 40 °C
Maximum Relative Humidity	80% up to 31 °C decreasing linearly to 50% at 40°C

## Calibration Default Settings (CAL dEF)

### Conductivity

Calibration factor	Reset to 1.000
--------------------	----------------

## Factory Default Settings (FCt dEF)

### Conductivity

Calibration factor	Reset to 1.000
Cell constant	1.00
Cell type	2-cell
Measuring range	0 to 2000 $\mu\text{S}/\text{cm}$
Line resistance	0.000 $\Omega$

### Temperature

Unit of measurement	°C
Temperature compensation	ATC On
Temperature coefficient	2.1% (Both process & calibration temp. coefficients)
Temperature coefficient type	Linear
MTC (ATC Off)	25 °C (Both process & calibration temperature)

### Controller Output

Controller type	Limit control
Relay status	De-energized
Relay 1 (SP1)	
Set point value	100 $\mu\text{S}$
Relay function	Low

	Hysteresis	20 $\mu$ S
	On-delay time	0 seconds
	Off-delay time	0 seconds
Relay 2 (SP2)		
	Set point value	1900 $\mu$ S
	Relay function	High
	Hysteresis	20 $\mu$ S
	On-delay time	0 seconds
	Off-delay time	0 seconds
<b>Display</b>		
	Backlight	On

## 7 LIST OF ACCESSORIES

### 7.1 Thermo Scientific Order Codes

#### Conductivity Controller Replacement and Accessories

Item Description	Order Code
Alpha CON 560 Controller	TSCONCP0560
Conductivity cell, Epoxy body, Graphite sensor, w/3-wire Pt100, k = 0.1	ECCONSEN89X
Conductivity cell, Epoxy body, Graphite sensor, w/3-wire Pt100, k = 1.0	ECCONSEN88X
Conductivity 2 Cell type probe, 0.1 - 200 $\mu$ S; Cell constant, K=0.1 with integrated Pt 100, Material SS316 and 25ft cable (open-ended)	ECCS1001S
Conductivity 2 Cell type probe, up to 200 mS; Cell constant, K=1.0 with integrated Pt 100, Material SS316 and 25ft cable (open-ended)	ECCS1010S

### 7.2 Eutech Instruments Order Code

#### Conductivity Controller Replacement and Accessories

Item Description	Order Code
Alpha COND 560 Controller	19505-40
Eutech Instruments Four-Electrode Conductivity Cell 3/4" NPT(M)	19503-00
100 Ohm Pt RTD Industrial Conductivity Cells Conductivity Cell; K=0.1, SS, In-Line; 100 Ohm Pt RTD ATC	19500-44
100 Ohm Pt RTD Industrial Conductivity Cells Conductivity Cell; K=1.0, SS, In-Line; 100 Ohm Pt RTD ATC	19500-45
100 Ohm Pt RTD Industrial Conductivity Cells Conductivity Cell; K=10.0 CPVC, In-Line; 100 Ohm Pt RTD ATC	19500-46

**NOTE:** Please contact your authorised distributor or dealer for the prices of extension measuring cables and other accessories such as tee joints, electrode assembly, and calibration solutions.

## 8 TROUBLESHOOTING

Problem	Cause	Solution
Power on, but no display	<ul style="list-style-type: none"> <li>a) Loose connections</li> <li>b) Incorrect output voltage of the power adaptor</li> <li>c) Cables not in correct polarity (+ and – position)</li> </ul>	<ul style="list-style-type: none"> <li>a) Ensure cables make good contact</li> <li>b) Use an power adaptor with specified output voltage</li> <li>c) Re-wire loop cables with correct polarity</li> </ul>
Unstable conductivity reading	<ul style="list-style-type: none"> <li>a) Air bubbles in the probe</li> <li>b) Dirty probe</li> <li>c) Probe not deep enough in sample</li> </ul>	<ul style="list-style-type: none"> <li>a) Tap probe to remove air bubbles</li> <li>b) Clean probe and recalibrate</li> <li>c) Ensure that the sample entirely covers the sensor of the probe</li> </ul>
Oscillating temperature readings	<ul style="list-style-type: none"> <li>a) Electrical noise interference</li> </ul>	<ul style="list-style-type: none"> <li>a) Ensure shield wire is properly connected to pin 7</li> </ul>
Slow response	<ul style="list-style-type: none"> <li>a) Dirty / Oily probe</li> </ul>	<ul style="list-style-type: none"> <li>a) Clean probe</li> </ul>
Blinking ATC	<ul style="list-style-type: none"> <li>a) No temperature probe connection during ATC mode</li> </ul>	<ul style="list-style-type: none"> <li>a) Ensure temperature sensing cable makes good contact</li> </ul>
Blinking electrode annunciator 	<ul style="list-style-type: none"> <li>a) Error in calibration</li> <li>b) Conductivity value of the calibration standard is not within acceptable range</li> </ul>	<ul style="list-style-type: none"> <li>a) Ensure calibration standard solution is not contaminated. Ensure electrode is clean</li> <li>b) Ensure calibration standard is within 10 to 100% of full-scale of the selected measuring range</li> </ul>
Or (Conductivity)	<ul style="list-style-type: none"> <li>a) Conductivity reading is above the selected measuring range</li> </ul>	<ul style="list-style-type: none"> <li>a) Ensure correct conductivity measurement range is selected</li> </ul>
Or/Ur (Temperature)	<ul style="list-style-type: none"> <li>a) Temperature probe is not connected when ATC enabled</li> <li>b) Temperature value exceeds above/ below the specified range</li> </ul>	<ul style="list-style-type: none"> <li>a) Ensure electrode makes good contact with controller</li> <li>b) Ensure temperature calibration is done properly. Ensure process temperature is within the specified range</li> </ul>

## 9 GENERAL INFORMATION

### 9.1 Warranty

This Controller is supplied with a one-year warranty against significant deviations in material and workmanship from date of purchase and a six-month warranty for probe. Each instrument will have a warranty card with a specific serial number. The warranty card must be endorsed by the Authorized Distributor at the point of sale.

If repair or adjustment is necessary and has not been the result of abuse or misuse within the designated period, please return – freight pre-paid – and correction will be made without charge. Thermo Scientific/ Eutech will determine if the product problem is due to deviations or customer misuse.

Out of warranty products will be repaired on a charged basis.

#### Exclusions

The warranty on your instrument shall not apply to defects resulting from:

- Improper or inadequate maintenance by customer
- Unauthorized modification or misuse
- Operation outside of the environment specifications of the products

### 9.2 Return of Goods

Authorization must be obtained from our Customer Service Department or authorized distributor before returning items for any reason. A “Return Goods Authorization” (RGA) form is available through our authorized distributor. Please include data regarding the reason the items are to be returned. For your protection, items must be carefully packed to prevent damage in shipment and insured against possible damage or loss. Thermo Scientific will not be responsible for damage resulting from careless or insufficient packing. A restocking charge will be made on all unauthorized returns.

**NOTE:** Thermo Scientific reserves the right to make improvements in design, construction, and appearance of products without notice.

### 9.3 Guidelines for Returning Unit for Repair

Use the original packaging material if possible when shipping the unit for repair. Otherwise wrap it with bubble pack and use a corrugated box for additional

protection. Include a brief description of any faults suspected for the convenience of Customer Service Dept., if possible.

## **9.4 Maintenance and Cleaning**

### **Maintenance**

The **Alpha COND 560 Controller** contains no user repairable components. Please contact your authorized distributor if there is any problem with the unit.

### **Cleaning**

To remove dust, dirt and spots, the external surfaces of the Conductivity Controller may be wiped with a damp, lint-free cloth. A mild household cleaner can also be used if necessary.

## 10 APPENDICES

### 10.1 Appendix 2 Conductivity of various aqueous solutions

At Temperature 25 °C / 77 °F

Solution	Conductivity	Resistivity
Ultra-pure Water	0.055 $\mu\text{S}/\text{cm}$	18.18 $\text{M}\Omega\text{-cm}$
Power Plant Boiler Water	0.05 - 1 $\mu\text{S}/\text{cm}$	1 - 18 $\text{M}\Omega\text{-cm}$
Distilled Water	0.5 $\mu\text{S}/\text{cm}$	2 $\text{M}\Omega\text{-cm}$
De-ionized Water	0.1 - 10 $\mu\text{S}/\text{cm}$	0.1 - 10 $\text{M}\Omega\text{-cm}$
De-mineralized Water	1 - 80 $\mu\text{S}/\text{cm}$	0.01 - 1 $\text{M}\Omega\text{-cm}$
Mountain Water	10 $\mu\text{S}/\text{cm}$	0.1 $\text{M}\Omega\text{-cm}$
Drinking Water	0.5 - 1 $\text{mS}/\text{cm}$	1 - 2 $\text{k}\Omega\text{-cm}$
Waste-water	0.9 - 9 $\text{mS}/\text{cm}$	0.1 - 1 $\text{k}\Omega\text{-cm}$
Potable Water Maximum	1.5 $\text{mS}/\text{cm}$	0.7 $\text{k}\Omega\text{-cm}$
Brackish Water	1 - 80 $\text{mS}/\text{cm}$	0.01 - 1 $\text{k}\Omega\text{-cm}$
Industrial Process Water	7 - 140 $\text{mS}/\text{cm}$	Rarely stated
Ocean Water	53 $\text{mS}/\text{cm}$	Rarely stated

## 10.2 Appendix 2 Graphical Representation of the Function of Hysteresis

SP1 = 100  $\mu\text{S}$  & Set to LO  
SP2 = 1900  $\mu\text{S}$  & Set to HI

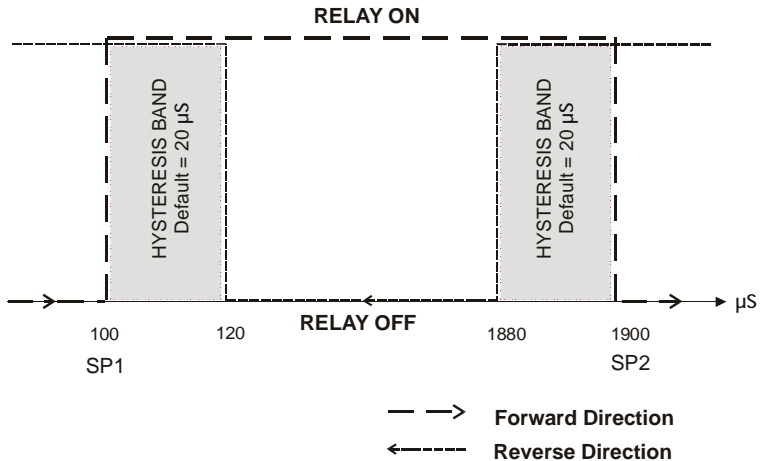

The relay of the conductivity controller activates when the set-point is reached (forward direction). In the reverse direction, it does not de-activate when the value reaches the set-point. Instead, it continues to be active till the value reaches the amount set by the Hysteresis band.

**Example:** You have set your high set point at 1900  $\mu\text{S}$  and your hysteresis value at 20  $\mu\text{S}$ . If your measured value overshoots 1900  $\mu\text{S}$ , the controller's relay activates. The actions of the external device will cause the solution's conductivity to drop. The relay will deactivate, when the conductivity value drops below 1880  $\mu\text{S}$ .

## 10.3 Appendix 3 General Instructions Concerning Controller Setting

Control characteristic of controller used as limit value switch

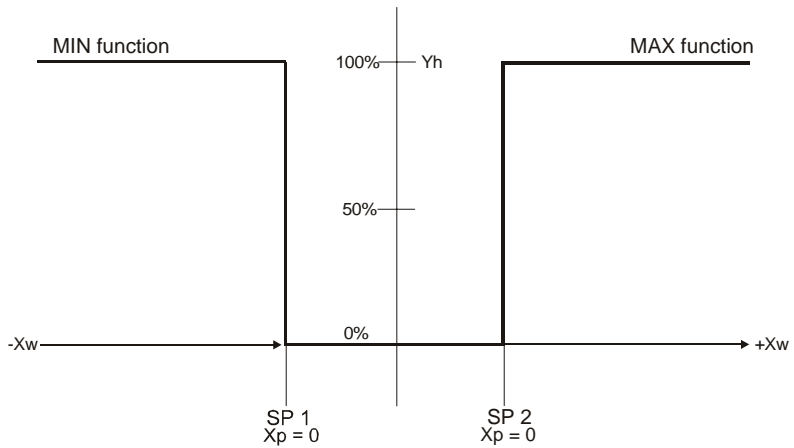

## 10.4 Appendix 4 - Abbreviations Used in LCD

Abbreviation	Description
AtC	Automatic Temperature Compensation
CAL	Calibration mode
C.°C	Calibration temperature
CdAt	Electrode properties
CEL	Cell
CnFg	Configuration
Cntr	Controller
C.tC	Temperature coefficient for calibration liquid
dEF	Default values
dEEen	De-energized
En	Energized
FCt	Factory (defaults)
HI	High limit
HOLD	Relay functions are hold
HyS	Hysteresis
K	Cell constant
L.Ad	Linear resistance
L.Ct	Limit control
Lin	Linear
LitE	Backlight
LO	Low limit
MEAS	Measurement mode
OF.d	Off delay
On.d	On delay
Or	Reading is over range
P.°C	Process temperature
P.tC	Temperature coefficient for process liquid
PUr	Pure water
rAng	Range

Set	Setting
SETUP	Setup mode
SP1	1 <sup>st</sup> Set point
SP2	2 <sup>nd</sup> Set point
tC	Temperature Coefficient
tyP	Type
Ur	Reading is under range







## Water Analysis Instruments



### North America

166 Cummings Center  
Beverly, MA 01915 USA  
Toll Free: 1-800-225-1480  
Tel: 1-978-232-6000  
Dom. Fax: 1-978-232-6015  
Int'l Fax: 978-232-6031

### Europe

P.O. Box 254, 3860 AG Nijkerk  
Wallerstraat 125K, 3862 CN Nijkerk,  
Netherlands  
Tel: (31) 033-2463887  
Fax: (31) 033-2460832

### Asia Pacific

Blk 55, Ayer Rajah Crescent  
#04-16/24, Singapore 139949  
Tel: 65-6778-6876  
Fax: 65-6773-0836

[www.thermo.com/process](http://www.thermo.com/process)

© 2009 Thermo Fisher Scientific Inc.

All rights reserved. Thermo Fisher Scientific Inc.