

# Infrared Thermometry and its Applications

Temperature is an important variable in manufacturing, quality control, and maintenance processes.

Monitoring temperature insures that processes are operating consistently under optimum conditions which results in improved product quality, increased productivity, and reduced downtime. Infrared temperature measurement has been used successfully for years in research and manufacturing applications. Recent innovations, however, have dramatically lowered costs, increased accuracies, and reduced sensor size making this technology available to a new group of users and applications.

## What is Infrared Temperature Measurement?

The infrared spectral range is an invisible portion of the electromagnetic spectrum extending from 0.7 to 1000 microns. Any object warmer than absolute zero (0 Kelvin) emits energy somewhere within this range. Infrared energy is also transmitted through objects from another source and reflected off the surface of an object.

Infrared thermometers sense emitted, reflected, and transmitted energy from an object and translate this information into a temperature reading. In essence, energy passes through the unit's optical system and is converted to an electrical signal at the detector. The signal is displayed or converted to a standard output (°F or °C).

## Terminology

There are two very important terms to understand when working with infrared thermometers:

*emissivity and distance-to-spot size ratio.*

*Emissivity* is the ratio of radiation emitted by a surface to the radiation emitted by a perfect black body at the same temperature. It is also described as an object's ability to emit or absorb infrared radiation. A perfect black body neither reflects nor transmits energy and has an emissivity of 1.0.

Infrared thermometers are available with fixed and adjustable emissivity. Most organic materials and painted or oxidized surfaces have an emissivity of 0.95; thus most units with fixed emissivity are preset at 0.95. Please see the following table for common emissivities.

Material	Emissivity
Asphalt	0.93 to 0.95
Ceramics and brick	0.80 to 0.95
Cloth	0.95
Concrete	0.94 to 0.95
Glass	0.76 to 0.85
Metals, unoxidized	0.02 to 0.21
Painted surfaces	0.74 to 0.96
Paper	0.50 to 0.95
Rubber	0.95
Sand	0.90
Snow	0.82 to 0.89
Soil	0.90 to 0.98
Steel, iron, oxidized	0.65 to 0.95
Steel, stainless	0.10 to 0.80
Water	0.93

Wood	0.89 to 0.94
------	--------------

*Distance-to-spot size ratio* is the relationship between the distance of the measuring device from the surface and the portion of the surface being measured. This ratio varies from unit to unit. The following example applies to a unit with a distance-to-spot size ratio of 6:1.

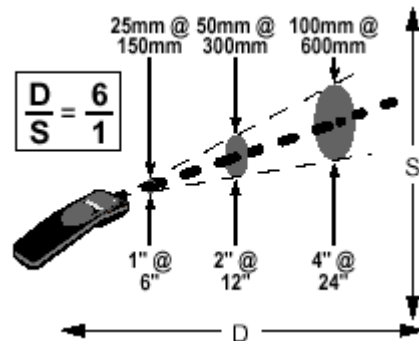

## Advantages and Applications

Because infrared thermometers measure temperature without physically touching the object, they offer distinct advantages over contact thermometers. Infrared temperature measurement is ideal in cases:

- *the object is too hot to touch*
- *the object is difficult to reach*
- *the substance must remain contaminant free*
- *the material is soft or wet or could be scratched or torn by a standard contact thermometer*
- *the object is moving*
- *the measurement must be as fast as possible*

Furthermore, because the thermometer does not come in contact with the object:

- *heat is NOT drawn away from the object affecting its true temperature (improving repeatability)*
- *infrared thermometers generally offer a longer life*

Infrared thermometry is used widely in the following industries/applications:

**Industrial/Electrical:** Monitor steam systems, boiler operations, and motor/engine cooling systems performance; detect hot spots in electrical systems, panels and motor bearings. Widely used in all types of industries such as food, veterinary, paper, rubber, textiles, glass, plastics, metals, gas/electric utilities, cement, tires, pharmaceutical, asphalt, roofing, electronics, carpet/floor covering, and many more.

**Heating and air conditioning:** Monitor furnace and duct leakage; detect insulation breakdown; check ceilings, walls and floors for proper room temperature, heat loss and gain.

**Food safety:** Fast and convenient screening tool for both cold and hot foods for Food Safety and HACCP. No contamination or damage to the product. Easily take temperature of products moving on conveyors or hard to reach places. Verify equipment performance sanitation and process temperature conditions. Scan cooling systems, refrigerated display cases, trucks and storage areas before loading or stacking.

**Educational:** Non-laser models are economical and safe for student use.

**Agriculture:** Monitor plant temperatures for stress, monitor animal bedding to detect spoiling.

**Fire Safety:** To detect hot spots in walls, floors, etc. after fire is extinguished.

### Potential Limitations

Infrared temperature measurement does have limitations and these should be considered before suggesting an IR thermometer for use in a given application.

IR measurement is affected by an object's emissivity. Most organic materials and painted surfaces have an emissivity of 0.95 (the standard pre-set in fixed emissivity units). Inaccurate readings result, however, when measuring shiny or polished metal surfaces. To compensate, the area being measured can be covered with masking tape or flat black paint. After the temperature of the tape or paint has come to an equilibrium with that of the surface, the area can be accurately measured. An IR thermometer with adjustable emissivity may also be employed.

It is also important to remember that the target area diameter increases proportionally as the distance from the thermometer to the surface increases (distance-to-spot size ratio). The unit is taking an average temperature of the target area and a larger area may result in less accurate measurements if temperatures vary across a given surface.

Eutech's [35625-00](#) and [35625-10](#) (with laser sighting) represent price breakthrough in non-contact temperature measurement. These instruments have a 500 msec response time, they are °C/°F switchable, and have a wide range of 0 to 500°F (-18 to 260°C). The 35625-00 and 35625-10 have fixed emissivity at 0.95 for use in a wide range of applications.