

Instruction Manual

CyberScan CON 10/100/200

Hand-held Conductivity/TDS/Temperature Meter



ISO 9001
CERTIFIED

EUTECH
INSTRUMENTS

Technology Made Easy...

Preface

This manual serves to explain the use of the CyberScan series Conductivity meters. The models covered are the CyberScan CON 10, CyberScan CON 100 and CyberScan CON 200 portable conductivity and total dissolved solids meters.

This manual functions in two ways: first, as a step by step guide to help the user operate the meter; second, it serves as a handy reference guide.

This manual is written to cover as many anticipated applications of the CyberScan Conductivity meters as possible. If there are doubts in the use of the CyberScan Conductivity meters, do not hesitate to contact the nearest Eutech Instruments Authorized Distributor.

Eutech Instruments cannot accept any responsibility for damage or malfunction to the meter caused by improper use of the instrument. Remember to fill in the guarantee card and mail it back to your authorized distributor or Eutech Instruments Pte Ltd.

The information presented in this manual is subjected to change without notice as improvements are made, and does not represent a commitment on the part of Eutech Instruments Pte Ltd.

Copyright © 1998 Eutech Instruments Pte Ltd. All rights reserved.

Revised in September 2001.

TABLE OF CONTENTS

1	INTRODUCTION	1
2	DISPLAY AND KEYPAD FUNCTIONS	2
2.1	Display	2
2.2	Keypad	3
3	PREPARATION	5
3.1	Inserting the Batteries	5
3.2	Attaching the electrode holder onto the meter	7
3.3	Attaching the electrode onto the electrode holder	8
3.4	Connecting the A.C. adapter	8
3.5	Connecting the RS 232C cable (only for CyberScan CON 200)	9
4	CALIBRATION	12
4.1	Standard solutions for calibration	12
4.2	Preparing the meter for calibration	12
4.3	Calibration procedure	13
5	MEASUREMENT	19
5.1	Automatic Temperature Compensation	19
5.2	Manual Temperature Compensation	20
5.3	Taking measurements	21
6	MEMORY FUNCTIONS (IN CYBERSCAN CON 100 & 200 ONLY)	22
6.1	Data Input	22
6.2	Memory Recall	22
6.3	Memory Clear	23
7	PRINT FUNCTION (IN CYBERSCAN 200 ONLY)	24
7.1	Printing data	24
7.2	Printing errors	25
7.3	Sending data to the computer	25
7.4	Printing measurement data	25
7.5	Printing data from memory	25
8	SETTING UP THE CYBERSCAN (FOR CYBERSCAN CON 100/200 ONLY)	27
8.1	SETUP program	27
8.2	Program 1: Common functions	28
8.3	Program 2: Instruments Setup	30
8.4	Program 3: TDS Setup (in CyberScan CON 200 only)	33
8.5	Program 4: Communication Setup (in CyberScan CON 200 only)	35
9	CYBERCOMM POTRABLE - DATA ACQUISITION SOFTWARE (DAS FOR CYBERSCAN CON 200 ONLY)	38
9.1	System Requirements	38
9.2	Loading CYBERCOMM PORTABLE	38
9.3	Running CyberComm Portable	44
9.4	Capturing And Printing Data Into Computer Using CyberComm Portable	48
9.5	Trouble-shooting Guide	49
10	TROUBLESHOOTING & ELECTRODE CARE	50
10.1	Troubleshooting	50
10.2	Electrode Care	52
11	ADDITIONAL INFORMATION	53
12	ACCESSORIES AND CALIBRATION BUFFER SOLUTIONS	55
12.1	Replacement Meter and Meter Accessories	55
12.2	Calibration Solutions	56
13	SPECIFICATIONS OF CYBERSCAN CON 10/100/200	57
14	WARRANTY & RETURN OF ITEMS	58

1 INTRODUCTION

Thank you for selecting Eutech Instruments portable meter. This meter is a microprocessor-based instrument that is designed to be handy, user-friendly and capable of allowing one-hand operation. It has a large customized LCD for clear and easy reading. It also has user-friendly features, all of which are accessible through the membrane keypad. It is a unique and intelligent instrument that has capability to cater to the preferences of the discerning individual. You have one of three models:

- CON 10 meter:
- CON 100 meter:
- CON 200 meter

Your meter includes a conductivity electrode (cell constant $K = 1.0$) with built-in temperature sensor (Order Code: EC-CONSEN41B for CON 10, EC-CONSEN21B for CON 100/200), and batteries. Please read this manual thoroughly before operating your meter.

2 DISPLAY AND KEYPAD FUNCTIONS

2.1 Display

The LCD has a primary and secondary display. The primary display shows the measured conductivity or TDS reading. The secondary display shows the measured temperature. The display also shows error messages, keypad functions and program functions. See Figure 1.

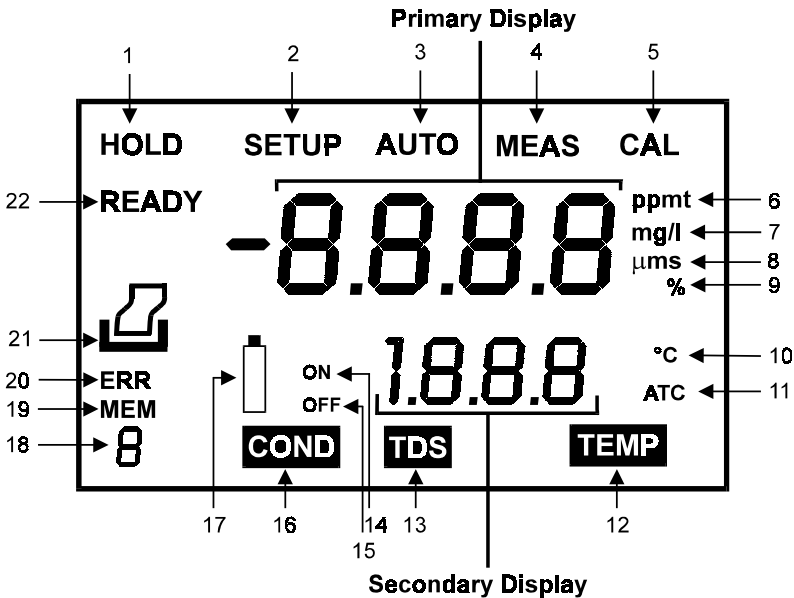



Figure 1: Full LCD Screen

- | | | |
|---|--|---|
| 1. HOLD indicator | 9. Temperature coefficient in % | 16. CONDuctivity mode indicator |
| 2. SETUp mode indicator | 10. Temperature indicator | 17. Low battery indicator |
| 3. AUTO indicator | 11. Automatic Temperature Compensation indicator | 18. Index number of the memory recalled or stored (except CON 10) |
| 4. MEASurement mode indicator | 12. TEMPerature mode indicator | 19. MEMory recall mode indicator (except CON 10) |
| 5. CALibration indicator | 13. TDS mode indicator | 20. ERRor indicator |
| 6. parts per thousand or parts per million indicator (for CON 10 & 200 meters only) | 14. ON/OFF indicator - option is turned on | 21. Printer indicator (for CON 200 only) |
| 7. milligrams per liter or grams per liter indicator (for CON 10 & 200 meters only) | 15. ON/OFF indicator - option is turned off | 22. READY indicator |
| 8. microsiemens or millisiemens indicator | | |

2.2 Keypad

The large membrane keypad makes the instrument easy to use. Each button, when pressed, has a corresponding graphic indicator on the LCD. See Figure 2. Some buttons have several functions depending on its mode of operation.

Key	Function
ON/OFF	Powers on and shuts off the meter. When you switch on the meter, the meter starts up in the mode that you last switched off from. For example, if you shut the meter off in TDS measurement mode (only in CON 10 & CON 200 meters), the meter will be in TDS measurement mode when you switch the meter on.
HOLD	Freezes the measured reading. To activate, press HOLD while in measurement mode. To release, press HOLD again.
MODE	Selects the measurement parameter. ~ CON 10 meter: Toggles between conductivity, TDS and temperature. ~ CON 100 meter: Toggles between conductivity and temperature. ~ CON 200 meter: Toggles between conductivity, TDS and temperature.
CAL/MEAS	Toggles between Calibration and Measurement mode. NOTE: Temperature calibration is available from conductivity calibration mode; see section 4.3 for directions.
ENTER / RANGE	<i>ENTER function:</i> Press to confirm values in Calibration mode and to confirm selections in SETUP mode. <i>RANGE function:</i> Press to enter manual ranging function. The MEAS indicator blinks while in manual ranging function.
MI/▲ & MR/▼ (CyberScan CON 100/200) ▲ & ▼ (CyberScan CON 10)	<u>In Measurement mode:</u> Press MI/▲ (memory input) to store values with its corresponding temperature values in the memory. Press MR (memory recall) to retrieve data from memory. <u>In Calibration mode:</u> Press to scroll through calibration values. <u>In SETUP mode:</u> Press to scroll through the setup subgroup programs.
SET (CyberScan CON 100/200 only)	Takes you into the SETUP mode. This mode lets you customize meter preference and defaults, and view calibration, electrode offset data and select cell constant.
 (CyberScan CON 200 only)	Sends the displayed data through the RS 232C connector to the peripheral device (computer or printer).

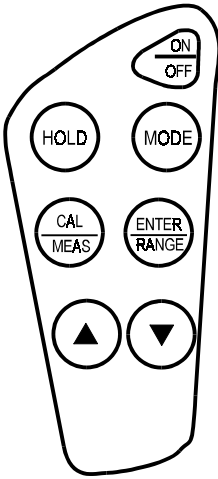

CyberScan CON 10

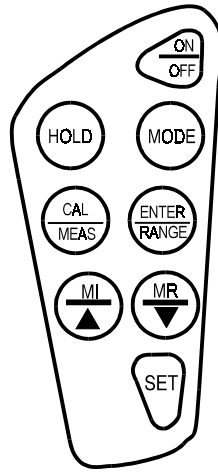

CyberScan CON 100

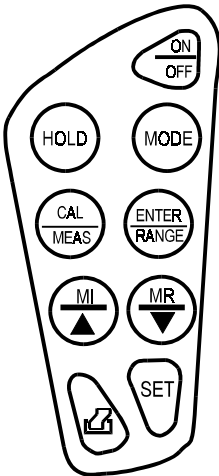

CyberScan CON 200

Figure 2: Keypad

3 PREPARATION

3.1 Inserting the Batteries

Four AAA batteries are included with your meter.

1. Use a Philips screwdriver to remove the two screws holding the battery cover. See Figure 3 below.
2. Lift meter stand to expose battery cover. Remove battery cover.
3. Insert batteries. Follow the diagram inside the cover for correct polarity.
4. Replace the battery cover into its original position using the two screws removed earlier.

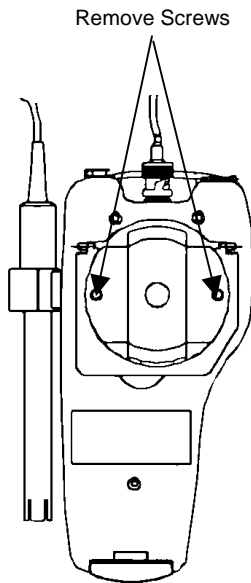

Figure 3: Back panel of meter showing battery compartment

To connect the Conductivity/TDS electrode with built-in temperature sensor:

- a) During this operation, it is important that water does not get onto the BNC connector. Also avoid touching the connector with soiled hands.

Slide the electrode connector of electrode over the socket of the meter (BNC connector). Ensure that the slot of the connector is inline with the protrusions of the socket.

Rotate the connector clockwise until it locks. Be careful not to use excessive force in this operation.

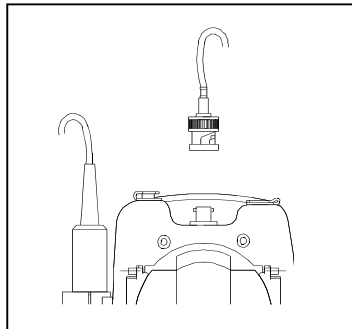

Figure 4: Connecting the Conductivity /TDS probe

- b) The built-in temperature probe uses a phono jack to connect with the socket on the meter. Insert the jack into the socket as shown in Figure 5.

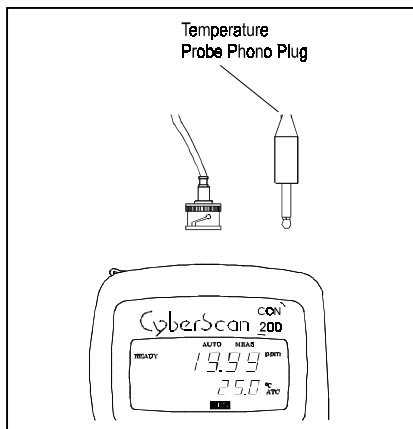

Figure 5: Connecting the built-in temperature sensor

3.2 Attaching the electrode holder onto the meter

The meter has a slot on the side for the attachment of the electrode via the electrode holder.

- a) The meter provides a slot on the side of the instrument for the electrode holder. Hold the electrode holder over the slot of the meter. Ensure the flange of the electrode holder is facing the slot. Note the orientation to make sure that it is the orientation that you desire (see figure below).
- b) Gently slide the flange of the electrode holder into the slot. Ensure that the electrode holder is fixed properly into the slot.

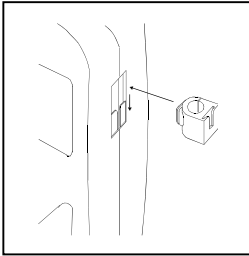

Figure 6: Attaching the electrode holder to the meter

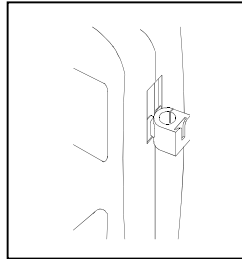

Figure 7: Sliding the electrode holder into the slot

3.2.1 Special Features

The electrode holder can be attached in different positions (multi-position) as shown. This allows you the flexibility in measurement and storage.

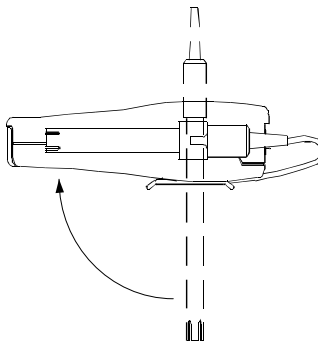

Figure 8: Multi-position of the electrode holder

3.3 Attaching the electrode onto the electrode holder

Your meter comes complete with an electrode holder. It is designed for easy use and installation. Care must always be taken to avoid use of excessive force in the process of attaching these components.

- a) Align the end of the electrode (sensor side) with the hole of the holder. Note that the top side of the holder is where the slot begins.
- b) Always ensure that the diameter of the electrode you intend to use is 12 mm. Otherwise, the electrode may not fit properly.
- c) Insert the electrode into the hole of the holder until the top housing of electrode touches the top of the holder. Remember not to force the electrode into the holder.

3.4 Connecting the A.C. adapter

The CyberScan CON 10/100/200 meter has the flexibility of operating from an A.C. power source. This is extremely useful if you have an A.C. source available near the meter (e.g. Laboratory).

1. Before plugging in the A.C. adapter, switch off the meter and the power source of the A.C. adapter. This is a safety precaution that should be adhered to safeguard your meter.
2. The A.C. adapter should have the following settings:
Output Voltage: 9 V D.C.
Current: 500 mA

NOTE: Ensure that the input mains voltage (110/220/240 V) matches your adapter requirements.

3. Insert the D.C. jack into the socket of the meter as shown in Figure 9.
4. Switch on the power to the adapter, followed by the meter.

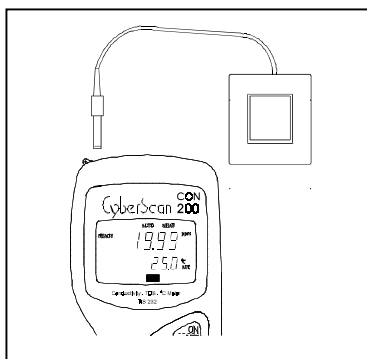

Figure 9: Inserting the A.C. power adapter

3.5 Connecting the RS 232C cable (only for CyberScan CON 200)

The CyberScan Conductivity CON 200 meter provides an RS 232C output for you to transmit the reading either to a printer or a computer. This is extremely useful in instances where the meter is used for continuous monitoring of a certain process or experiment. The data output to the printer or computer can be then evaluated.

The data is output in the ASCII format. This format allows the data to be imported by a wide variety of software that read ASCII data (e.g. LOTUS 123 C, Microsoft Excel, etc.).

Eutech Instruments also provides software that can capture the data transmitted into an ASCII file for later use.

- a) Open the communication port cover located at the bottom of the meter as shown in Figure 10. Do not use excessive force when doing this.
- b) Noting the orientation of the RS 232C connector, plug the RS 232C male connector into the RS 232C port of the meter.
- c) Fasten the connector by fastening the two screws at the side of the male connector.

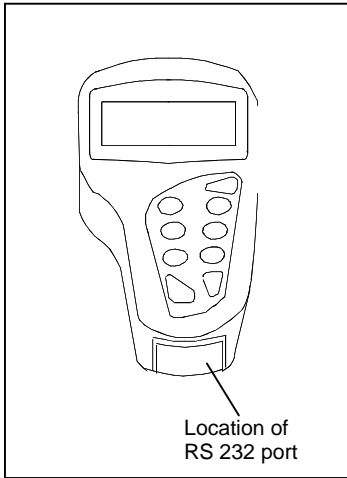

Figure 10: The CyberScan CON 200 RS 232 port

3.5.1 RS 232C Configuration

The CyberScan CON 200 meter has a 9-pin female RS 232C connector with the following pin-out:

PIN NO	DESCRIPTION
1	-
2	Transmit Data
3	-
4	DSR (Data Set Ready)
5	GND
6	-
7	CTS (Clear to Send)
8	-
9	-

A one-is-to-one connection can be made with a 9-pin RS 232C port of the computer.

In case the meter output has to be sent to a 25-pin RS 232C connector, the following cable configuration may be used:

CyberScan CON 200

25-pin connector

- 2 (TxD) ----- (RxD) 3
- 4 (DSR) ----- (DTR) 20
- 5 (GND) ----- (GND) 7
- 7 (CTS) ----- (RTS) 4

Refer to Figure 11 for the pin number position.

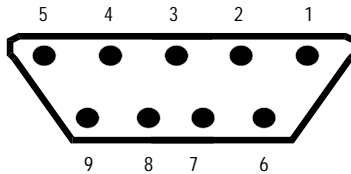



Figure 11: Pin number position of the 9-pin RS 232 port

The meter uses hardware handshake i.e. the meter expects both DSR and CTS lines to be active before it sends data. If the  key is pressed while the printer is not ready or if the printer is off, the meter displays error by blinking the printer and the ERR annunciators alternately, and waits for the printer to be ready. While the meter is displaying printer error, the user may press the CAL/MEAS key to return to the measurement (MEAS) mode.

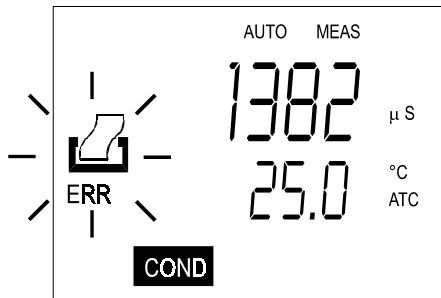

Figure 12: Error in printing

4 CALIBRATION

4.1 Standard solutions for calibration

Select conductivity or TDS calibration solution (available from the distributor) which is close to the expected conductivity of the sample that you want to measure. Ensure that the calibration solution which you use comes with a “Temperature vs Conductivity” or a “Temperature vs TDS” label on it. This information is required during calibration.

NOTE: Eutech’s calibration solutions are supplied in shatterproof bottles of 480 ml. Refer to section 12 for Ordering Information and details for other accessories.

In CON 100 meter, calibration is only done in the conductivity (COND) mode. The CON 10 and CON 200 meters allow calibration either in the conductivity range or the TDS range but not both. As such, a calibration in the TDS mode of a particular range will replace a prior calibration in the conductivity mode if both ranges are the same (i.e. Range 2 in COND and Range 2 in TDS).

In general, it is recommended that calibration be performed around a point close to 2/3 of full scale. For better accuracy, perform a calibration close to the expected measurement range prior to the measurement.

Corresponding TDS values are obtained by multiplying the recommended conductivity values by the TDS factor. The default TDS factor is 0.5.

4.2 Preparing the meter for calibration

Before starting calibration, make sure you are in the correct measurement mode. When you switch on the meter, the meter starts up in the measurement mode you shut it off in previously. For example, if you shut the meter off in COND measurement previously, the meter will come back into COND measurement when you switch the meter on.

Before calibrating, select the correct mode by pressing the MODE key. There are 3 modes:

COND	for conductivity measurements,
TDS	for total dissolved solids (TDS) measurements,
TEMP	for temperature measurements.

4.3 Calibration procedure

4.3.1 Procedure for conductivity calibration (CyberScan CON 10/100/200)

1. If necessary, press the MODE key to select COND mode. The μS indicator appears in the upper right hand corner of the display.
2. Rinse the probe thoroughly with de-ionized water or a rinse solution.
3. Dip the probe into the buffer solution. The end of the probe must be completely immersed into the buffer solution. Stir the probe gently to create a homogeneous sample. Agitate the probe in the solution to dislodge air bubbles that are trapped in the probe.
4. Press the CAL/MEAS key to enter the COND calibration mode. The CAL indicator will be shown. The primary display will show the measured reading.
5. Use the \blacktriangle or \blacktriangledown key for CON 10, or MI/ \blacktriangle or MR/ \blacktriangledown key for CON 100/200, to adjust the measured value to that of the standard solution.
6. Wait for the measured conductivity value to stabilize. See Figure 13 for the conductivity calibration procedure.

NOTE: To exit without confirming the calibration, press the CAL/MEAS key.

For calibration in the other ranges (maximum: 5 ranges, repeat steps of the procedure, this time using a solution with a conductivity of a different range).

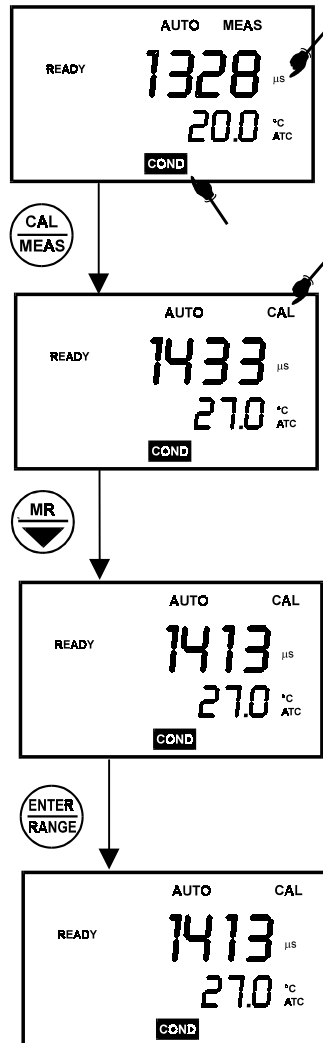

Figure 13: Conductivity calibration procedure

4.3.2 Procedure for TDS calibration (CyberScan CON 10/200 only)

Two methods are available for TDS calibration. The first method (Method 1) applies to both CyberScan CON 10 and 200 meters. Method 1 relies on the availability of a table that shows the TDS values of the TDS calibration buffer solution at various temperatures. The second method (Method 2) relies on the availability of conductivity-to-TDS conversion factors at standard temperature such as at 25 °C. Method 2 applies only to CyberScan CON 200 meter.

The advantage of Method 1 is that it is simpler to perform than Method 2. However, one should note that much of calibration buffer solutions do not reference the TDS values at temperatures other than 25 °C, and that without the use of proper conductivity-to-TDS conversion factor, this calibration may not be as accurate over a wider range of measurement.

Also, in some cases, the meter may not accept the TDS value input into it giving an error message because the calibration value exceeds the allowable slope adjustment limits of the meter when using a default conductivity-to-TDS conversion factor such as 0.50.

Method 2 overcomes the shortcomings of Method 1 by ensuring the TDS measurement accuracy over a broader range of TDS measurements around the calibration value. The meter will virtually accept any TDS calibration input from virtually any commonly used TDS calibration buffer solution. The only requirement is that the buffer solution indicates the TDS at a standard temperature such as 25 °C.

NOTE: It is important to have knowledge of the conductivity-to-TDS conversion factor or the factor can be calculated using the formula below:

$$\text{Factor} = \frac{\text{TDS}}{\text{Conductivity}} \quad @ 25^{\circ}\text{C}$$

TDS calibration: Method 1

1. Select the TDS standard solution with a value that is closest to the measurements expected in the sample (in this manual, the KCl standard solution 1413 μS is about 706.5 ppm).

Check this number by multiplying the conductivity reading by the factor and the result should be the TDS in equivalent units.

2. First, pour enough of the selected sample into two separate clean containers so as to allow the probe to be immersed up to the bleed hole.
3. Rinse the end of the probe into one of the containers by gently stirring it in the standard solution. This helps remove contaminants that offset the calibration and introduce error.
4. Dip the rinsed probe into the other container containing the unused solution.
5. Allow the probe some time to stabilize to the solution temperature.
6. Select the TDS mode using the MODE key. Note the temperature of the calibration solution and find the corresponding TDS value of the calibrating solution at that temperature.

For example, the meter displays the temperature of 27 °C, and a TDS value of 720 ppm (when normalized to 25 °C) with the uncompensated value at 27 °C should be 733 ppm.

7. Upon pressing the CAL/MEAS key, the CAL annunciator on the screen will blink, indicating the calibration mode is on. The LCD displays the uncompensated TDS value.

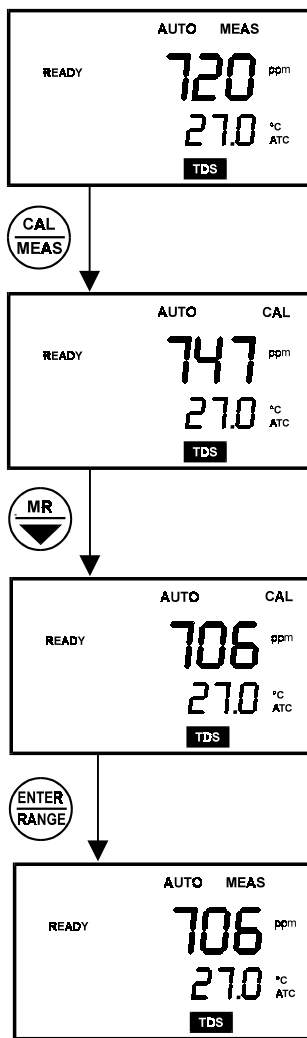

Figure 14: TDS calibration procedure Method 1

8. Use the ▲ or ▼ key for CyberScan CON 10, or MI/▲ or MR/▼ key for CyberScan 200 to scroll up or down respectively to the value of the standard solution at 25 °C.
9. Press the ENTER/RANGE key to confirm the calibration. The CAL indicator will stop flashing and remains on the screen for 3 seconds. Then the meter switches back into the measurement mode and the calibrated value, compensated to the current temperature, is shown on the display.

The display will now show 706 ppm that is the correct value of the standard solution at 27 °C. Measurements can be performed now.

10. To exit from this process without confirming the calibration, press the CAL/MEAS key.

For calibration in the other ranges (maximum: 5 ranges for CON 200 only) repeat steps of the procedure as outlined in Method 1, this time using a solution with a TDS of a different range.

Error upon confirmation

If an ERR error message appears, it probably means that the meter does not allow the slope adjustment that has been made via the calibration procedure given the value of the conductivity-to-TDS conversion factor currently in the memory.

If you are using CyberScan CON 200 meter, consider Method 2 of the TDS calibration. Press the CAL/MEAS key to escape the ERR message and abort the calibration attempt.

Inaccuracies after calibration

If the TDS value is not within 2 digits of the TDS standard solution value at 25 °C or 20 °C (depending upon which value was selected in the SETUP), an adjustment of either of the following is required.

- Temperature coefficient
- Calibration
- Conductivity-to-TDS conversion factor (see Method 2)

TDS calibration: Method 2 (for CyberScan CON 200 only)

1. Select the TDS standard solution with a value that is closest to the measurements expected in the sample (in this manual, the KCl standard solution 1413 µS is about 706.5 ppm at 25 °C).
2. Pour about 3 cm of the selected sample into two separate clean containers.
3. Rinse the end of the probe into one of the containers by gently stirring it in the standard solution. This helps remove contaminants that offset the calibration and introduce error.
4. Dip the rinsed probe into the other container containing the unused buffer solution.
5. If the Eutech standard solution is used, the correct Conductivity-to-TDS conversion factors are given for KCl, NaCl & 442 natural water formulation at 25 °C under the “Multiply By:” on the label. If another brand of TDS calibration is used, refer to the formula:

$$\text{Factor} = \frac{\text{TDS}}{\text{Conductivity}} \quad @ 25 \text{ } ^\circ\text{C}$$

Select the correct factor according to the protocol of the method, or that is closest to the solution to be measured.

6. Enter into the SETUP mode by pressing the SET key (note that this mode can be entered only from the MEAS mode).

Press the ENTER/RANGE key repeatedly until Program 3.0 (TDS factor) is shown.

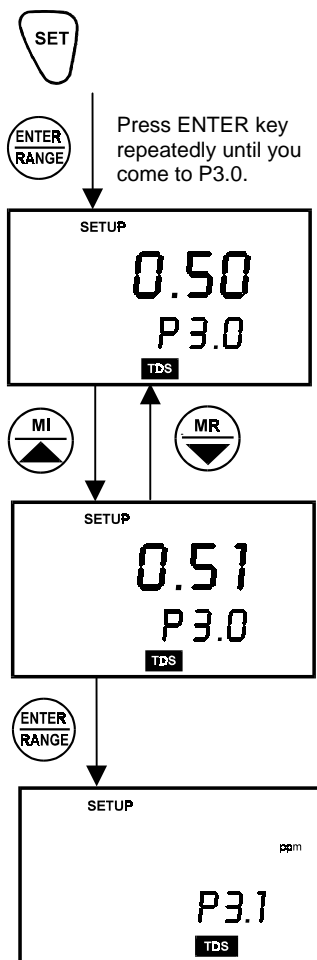

Figure 15: TDS calibration procedure Method 2

7. Using the MI/▲ or MR/▼ key, adjust the value of the primary display until it is the same or close to the selected/calculated value.

Confirm the selected value by pressing the ENTER/RANGE key.

8. Exit the SETUP mode and return to the MEAS mode by pressing the CAL/MEAS key upon completion of step 7. Press the MODE key until the TDS mode is entered. The TDS value will be the buffer solution value for the type of TDS solution selected. The value will also be temperature compensated and the conductivity-to-TDS conversion input will ensure greater accuracy over a broader range of TDS curves used.

5 MEASUREMENT

This meter is capable of taking measurements with automatic or manual temperature compensation. Automatic temperature compensation only occurs when a temperature sensor is plugged into the meter. If there is no temperature sensor plugged into the meter, the default manual temperature setting is automatically 25 °C. You can manually set the temperature to match your working conditions using a separate thermometer.

5.1 Automatic Temperature Compensation

For automatic temperature compensation (ATC) simply plug the built-in temperature sensor probe into the meter. The ATC indicator will light up on the LCD (see figure 16).

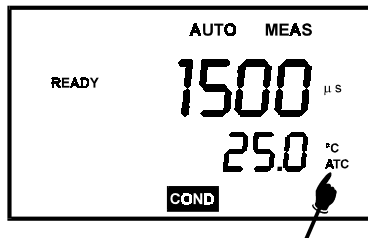

Figure 16: Automatic Temperature Compensation (ATC) indicator

5.2 Manual Temperature Compensation

IMPORTANT: For manual compensation, you must disconnect the temperature probe. The ATC annunciator will disappear from the LCD.

1. Press the MODE key to select TEMP mode.
2. Press the CAL/MEAS key to enter Temperature calibration mode. The CAL indicator will appear above the primary display.
3. The primary display shows the current conductivity/TDS reading and the secondary display shows the default temperature value 25 °C.
4. Check the temperature of your sample using an accurate thermometer.
5. Press the ▲ or ▼, or MI/▲ or MR/▼ key to set the temperature to the measured value obtained in step 4. To confirm, press ENTER/RANGE key.
6. Press the CAL/MEAS key to exit and return to conductivity measurement mode.

NOTE: To exit this program without confirming the manual temperature compensation value, DO NOT press ENTER/RANGE in step 5. Press CAL/MEAS instead.

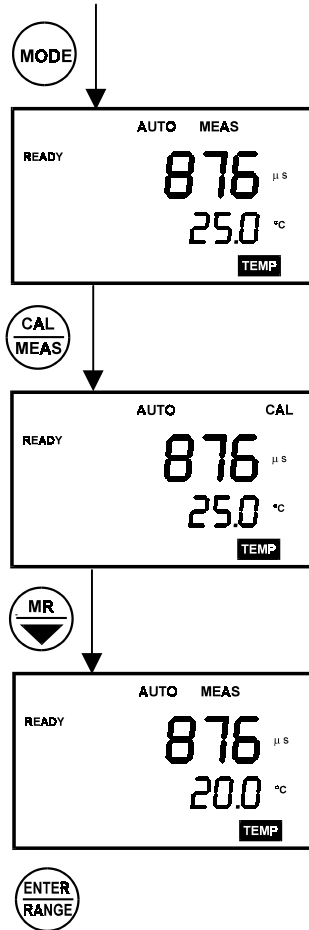

Figure 17: Setting the Temperature Compensation manually

5.3 Taking measurements

To take readings

1. Rinse the probe with de-ionized or distilled water before use to remove any impurities adhering to the probe body.
2. Press ON/OFF key to switch on the meter. The MEAS annunciator appears on the top center of the LCD. The ATC indicator appears in the lower right-hand corner to indicate Automatic Temperature Compensation.
3. Dip the probe into the sample.
4. When dipping the probe into the sample, the sensor of the electrode must be completely immersed into the sample. Stir the probe gently in the sample to create a homogeneous sample. Agitate the probe in the sample to dislodge air bubbles that are trapped in the probe.
5. Allow time for reading to stabilize. Note the reading on the display.

6 MEMORY FUNCTIONS (IN CYBERSCAN CON 100 & 200 ONLY)

6.1 Data Input

Press the MI/▲ key in the measurement (MEAS) mode, to input any data into the memory. The meter will automatically store the displayed data into the memory.

Model	Parameters
CON 100	Conductivity & temperature
CON 200	Conductivity & temperature and/or TDS & temperature

A total of 16 sets of data can be stored into the memory of the meter. The memory stored is identified by the memory number (in hexadecimal numbering format, i.e. from 0 to 9 followed by A to F) as displayed at the bottom left corner of the screen. The Last-In-First-Out (LIFO) method of memory management is used. See section 7.5 (Printing data from Memory) for illustration.

If the memory is full, the first memory contents (i.e. memory #1) will be erased. Memory #2 is reassigned #1 and so on, leaving the last space #F free to receive the latest input.

To store the value of the measurement into the memory of the meter, press the MI/▲ button. This will store both the parameter (conductivity or TDS) and the temperature into the memory. The MEM annunciator will be displayed briefly to indicate that the data has already been stored into memory. The memory number indicator, at the bottom left hand corner, will flash the number of memory stored.

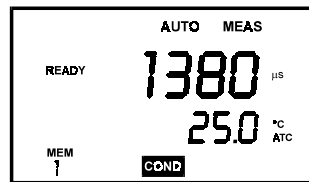

Figure 18: Data input to the memory

6.2 Memory Recall

Memory recall is invoked to recall the data sets stored in memory. Memory recall is activated in the following sequence:

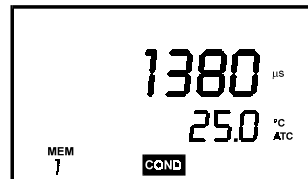

Figure 19: Memory Recall

1. Press the MR/▼ once to recall the last data set.

NOTE: Memory Recall (MR) is only accessible in the MEAS mode. Press CAL/MEAS key to return to the measurement mode.

2. Press the MR/▼ key again to recall the next latest data set stored.

NOTE: Memory data is retained even if the power of the unit is switched off (even with the batteries removed). Memory is erased when using Program 1.0 of SETUP (see section 8.2.1).

6.3 Memory Clear

Under normal operating conditions, fresh data sets will automatically be stored at the expense of data sets stored earlier. The instrument holds up to a maximum of 16 sets of data. The meter also has a feature that enables easy but safe clearing of memory facilities. The process to be followed in clearing the memory is outlined in SETUP (see section 8.2.1). The accessibility of this function through the SETUP mode is to limit accidental clearing of memory from the measurement mode.

7 PRINT FUNCTION (IN CYBERSCAN 200 ONLY)

7.1 Printing data

The CyberScan CON 200 meter is equipped with a  key that facilitates the printing of data into the computer in the form of a data file.

Using the CyberScan CON 200 meter with the printer

1. To use the CyberScan CON 200 meter directly with a printer, the printer should have either a 9-pin or a 25-pin RS 232 serial port.
2. Printer dip switches should match with the meter communication setup. The printer should have options to receive 8 data bits, even (2), odd (1) or none (0) parity bit and one (1) or two (2) stop bits. These parameters are standard printer options.
3. Use the cable provided to connect the meter to the printer. If the printer has a 25-pin connector, use a 9 to 25-pin converter (if available) or make your own cable taking note of the connection parameters as described in Section 3.5 (Connecting the RS 232 cable).
4. Set the dip switch of the printer to accept serial data. This is required if the printer has both serial and parallel interfaces. Set the dip switch to accept 8 data bits.
5. Switch on the meter.
6. Change the CON 200 meter setup parameters for the proper baud rate, parity and stop bits. Ensure that these parameters are identically set on both the printer and the meter.
7. Insert the paper and switch the printer on.
8. To send data to the printer, press the  key.

7.2 Printing errors

The meter displays an error by blinking the printer and error annunciators if the printer is not ready to receive data or if the printer is off. As soon as the printer is ready, the error display will automatically go off. While the meter is displaying the printer error, the user may press the CAL/MEAS key to go back to the measurement mode.

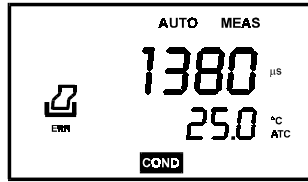

Figure 20: Display of printing error

7.3 Sending data to the computer

To send data to the computer, connect the RS 232C cable from the base of the meter to the COMM port 1 of the computer. Load and run the CYDATA data acquisition program ensuring that the parameters of the settings in the meter and the CYDATA are identical.

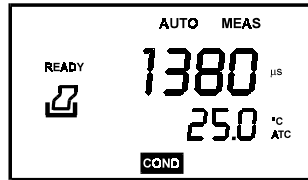



Figure 21: Sending data to the computer

To send data to the computer, press the  key.

7.4 Printing measurement data

To print any data that is currently being measured, press the  key. Note that the printing capability is available for the COND, TDS and TEMP modes.

The data will be printed onto the printer paper or the screen of the CYDATA program automatically as illustrated in Page 26.

7.5 Printing data from memory

The CyberScan CON 200 meter can print data that is stored in the memory. Firstly, ensure that the cables are properly connected to either the printer or the computer and the units are configured to receive the data from the meter.

Change the mode to the mode of measurement from which data needs to be printed.

Scroll to the data that needs to be printed by pressing the MR/▼ key. To print, press the  key. The data displayed will then be sent to the printer or the computer. An example of the printout is shown in Page 26.

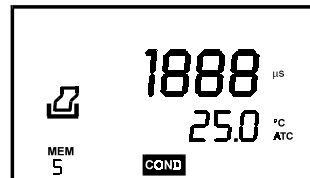

Figure 22: Printing data from memory

An example of a printout for Printing Measurement Data:

Cond:	1.00 mS	Temp: 33.2	Date: 07-30-96	Time: 14 : 00 : 09
Cond:	100 uS	Temp: 33.2	Date: 07-30-96	Time: 14 : 00 : 11
Cond:	10.0 uS	Temp: 33.2	Date: 07-30-96	Time: 14 : 00 : 14
Cond:	1.00 uS	Temp: 33.2	Date: 07-30-96	Time: 14 : 00 : 24
Cond:	199.9 uS	Temp: 33.2	Date: 07-30-96	Time: 14 : 00 : 28
Cond:	1999 uS	Temp: 33.2	Date: 07-30-96	Time: 14 : 00 : 30
Cond:	19.99 uS	Temp: 33.2	Date: 07-30-96	Time: 14 : 00 : 32
Cond:	199.9 uS	Temp: 33.2	Date: 07-30-96	Time: 14 : 00 : 34
TDS:	0.00 ppm	Temp: 33.2	Date: 07-30-96	Time: 14 : 00 : 59
TDS:	0.64 ppm	Temp: 33.2	Date: 07-30-96	Time: 14 : 01 : 32
TDS:	10.0 ppm	Temp: 33.2	Date: 07-30-96	Time: 14 : 01 : 38
TDS:	10.0 ppm	Temp: 33.2	Date: 07-30-96	Time: 14 : 01 : 40
TDS:	0.00 ppt	Temp: 33.2	Date: 07-30-96	Time: 14 : 01 : 59
TDS:	0.00 ppt	Temp: 33.2	Date: 07-30-96	Time: 14 : 02 : 02
TDS:	1.05 ppm	Temp: 33.2	Date: 07-30-96	Time: 14 : 01 : 06

An example of a printout for Printing Data from Memory

Mem: 7	Cond:	13.21 mS	Temp: 25.0	Date: 07-30-96	Time: 14 : 00 : 52
Mem: 6	Cond:	199.9 mS	Temp: 25.0	Date: 07-30-96	Time: 14 : 00 : 55
Mem: 5	Cond:	1999 uS	Temp: 25.0	Date: 07-30-96	Time: 14 : 00 : 57
Mem: 4	Cond:	14.52 uS	Temp: 25.0	Date: 07-30-96	Time: 14 : 00 : 59
Mem: 3	Cond:	14.52 uS	Temp: 25.0	Date: 07-30-96	Time: 14 : 01 : 06
Mem: 2	TDS:	0.06 ppm	Temp: 25.0	Date: 07-30-96	Time: 14 : 02 : 11
Mem: 1	TDS:	0.06 ppm	Temp: 25.0	Date: 07-30-96	Time: 14 : 02 : 13
Mem: 0	TDS:	0.06 ppm	Temp: 25.0	Date: 07-30-96	Time: 14 : 00 : 15

8 SETTING UP THE CYBERSCAN (FOR CYBERSCAN CON 100/200 ONLY)

8.1 SETUP program

In the SETUP mode in CyberScan CON 100/200 meter, there are four main programs. Each has been divided into several options. The programs and options are elaborated under the following sections:

PROGRAM	DESCRIPTION	SECTION
1	Common functions	8.2
2	Instruments setup	8.3
3	TDS units and factor	8.4
4	Communication parameters	8.5

To enter the SETUP mode, press the SET key from either the μS or ppm measurement MEAS mode. The meter automatically enters Program 1, Option 0 (P1.0). The meter prompts you with the program numbers in the secondary field of the display.

NOTE: Entry to SETUP is only accessible from the MEAS mode.

Selection of the ENTER/RANGE key confirms selection of the options chosen. The instrument then automatically scrolls to the next program. Within each program, you can use MI/▲ or MR/▼ key to make appropriate selections. There are some options that permit the viewing of data and are useful for diagnostic purposes.



Ensure that the ENTER/RANGE key is pressed to confirm your option in each program.

To exit from the program after the confirmation of choice or to abort from the SETUP mode, press the CAL/MEAS key to return to the MEAS mode.



To exit SETUP

NOTE: You may press the CAL/MEAS key to exit SETUP mode at any time.

8.2 Program 1: Common functions

The following 3 options are commonly used:

8.2.1 P1.0: Memory Clear

16 sets of readings can be stored in the meter. Both conductivity and temperature or TDS and temperature readings are stored.

ON	Clears all values stored in memory
OFF	Memory values remain in storage

Activation of this option by selecting ON and confirmation of memory clears all memory values. This is done by toggling the annunciator to ON using the MI/▲ or MR/▼ key, and pressing ENTER/RANGE to confirm the selection.

8.2.2 P1.1: %Temperature coefficient adjustment

The amount of change in conductivity per degree centigrade is referred to as the Temperature Coefficient, expressed in %/°C at a particular temperature. The meter provides the options of selecting the appropriate temperature coefficient, from 0.0 to 10.0 %/°C, depending on the type of solution measured.

The primary display indicates the temperature coefficient in %/°C. You can use the MI/▲ or MR/▼ key to scroll to a required value from 0.0 to 10.0 %/°C. Once you have made your selection, press ENTER/RANGE key to confirm the value.

The program will automatically scroll to the next SETUP parameter. Under default condition, the temperature coefficient is set to 2.0%/°C.

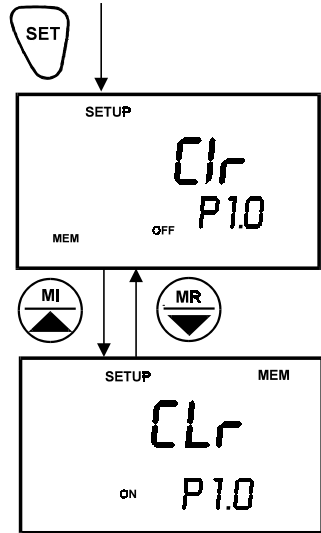

Figure 23: Memory clear display

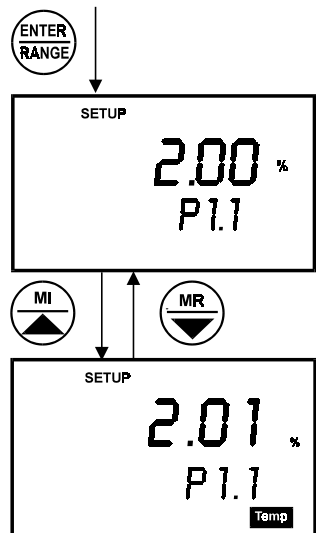

Figure 24: Temperature coefficient adjustment setup

8.2.3 P1.2: Calibration Status Display

The meter can be used to a maximum of five different calibrations in its five ranges of measurement. This SETUP program not only allows you to see if a particular range has been calibrated, but indicates the calibrated value. The secondary value shows P1.2. The range number (i.e. 1, 2, 3, 4 & 5) is indicated in the left corner of the display. While in P1.2, you can press MI/▲ or MR/▼ key which will scroll from range number 1 to 5 to display all the calibration status of the five ranges shown in the primary display. On pressing ENTER/RANGE key, the meter scrolls into the next SETUP parameter.

The meter will display the calibrated value in each range and the units (ppt/ppm/μS/mS) depending upon which modes were used during calibration. This allows a greater ease of use.

NOTE: The meter stores a maximum of five calibration values per range i.e. one calibration value per range. See Section 4 on Calibration. If the TDS factor (see Program 3.0) is changed, all previous TDS calibration values will not have a meaningful relationship to physical parameters and the meter displays "-- -- -- --" for all TDS calibration values.

This indicates that the meter is not calibrated in any of the five ranges using the new TDS factor.

NOTE: The previous calibration status would not be restored if the previous TDS factor were re-entered.

It is, therefore, necessary to calibrate the meter once the TDS factor is changed. Then, the SETUP mode will show the status of the five calibration ranges, indicating the TDS values in which you have calibrated with the respective range numbers.

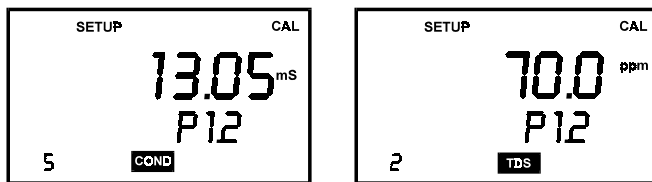

Figure 25: Calibration status display

Otherwise, the meter will continue to function with the previous calibration values and the new TDS factor, unless calibration is specifically reset by the SETUP option P2.2.

8.3 Program 2: Instruments Setup

8.3.1 P2.0: Ready selection

Activation of the READY option ensures that the READY indicator is displayed when the electrode reading stabilizes. READY options can be switched on or off by pressing the MI/▲ or MR/▼ key as indicated by ON or OFF in the display, followed by ENTER/RANGE key.

Under factory default, the option is ON.

ON	READY annunciator appears when variation is within 1 LSD (Least Significant Digit)
OFF	READY annunciator will not appear

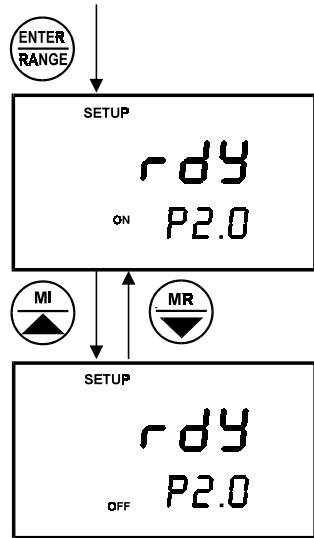

Figure 26: READY option

8.3.2 P2.1: Auto-Off

To conserve the power, the meter has an AUTO-OFF feature. Activation of the auto-off option will automatically power off the instrument 20 minutes after the last key selection. This feature is useful for conserving battery power. If this feature is not required, it can be switched off by using the MI/▲ or MR/▼ key, and pressing ENTER/RANGE key.

Under default condition, the option is activated.

ON	Meter switches off automatically 20 minutes after the last key operation
OFF	Meter will operate continuously until switched off manually using the ON/OFF key

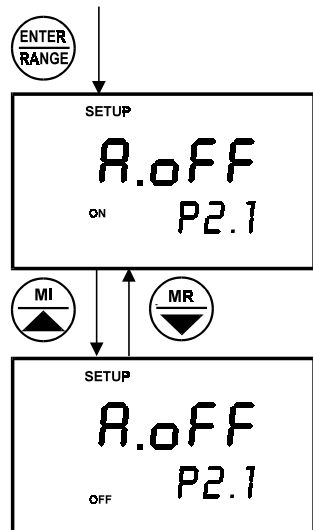

Figure 27: Auto-Off option

8.3.3 P2.2: Calibration Reset

P2.2 provides the option to reset all user selectable functions to the default settings. If you toggle the annunciator to ON using the MI/▲ or MR/▼ key, and press ENTER/RANGE key, all data will be reset. **RESET clears all calibration data in memory (of both conductivity and TDS).** You need to power ON the instrument before proceeding with any other functions.

Under default condition, RESET option is OFF.

NOTE: Data cannot be selectively deleted.

ON	Reset all calibration points
OFF	Reset off

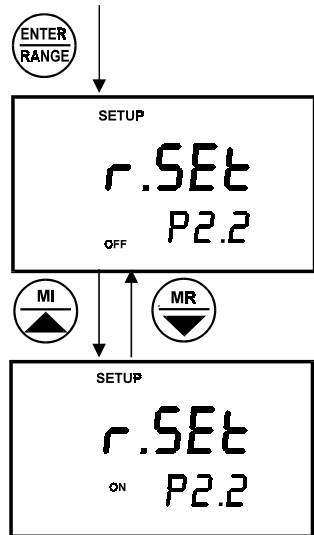

Figure 28: The RESET option

8.3.4 P2.3: Temperature Normalization

The ATC (Automatic Temperature Compensation) function automatically compensates for the variation caused by temperature difference during measurement and at the standard temperature (20 or 25 °C) and gives the corrected read-out of the equivalent conductivity of the solution. Hence, the conductivity/TDS can be normalized to display the equivalent conductivity/TDS at either 20 or 25 °C.

Normalization temperature can be selected between 20 & 25 °C using the MI/▲ or MR/▼ key. The primary display shows normalization temperature. Pressing ENTER/RANGE key registers the selected temperature at which the conductivity/TDS value is normalized. Default is at 25 °C.

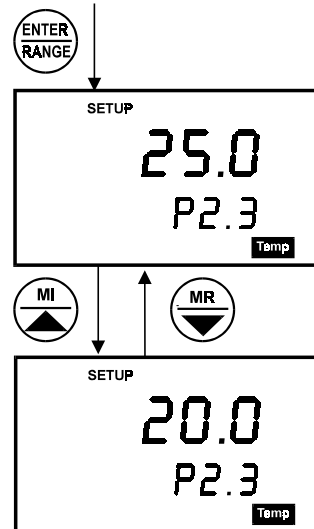

Figure 29: The Temperature Normalization option

8.3.5 P2.4: Cell Constant Selection - 0.1 / 1.0 / 10.0

This option allows you to select the cell constant of the electrode supplied has a nominal cell constant of 1.0. This option is important to obtain optimal readings in the various ranges of measurement. A table is shown below for K value selection of electrodes.

Ranges available	K=0.1	K=1.0	K=10.0
0.00 -19.99 μ S	*	*	
0.0 -199.9 μ S	*	*	
0 - 1999 μ S		*	
0.00 - 19.99 mS		*	*
0.0 - 199.9 mS		*	*

In Program 2.4, use the MI/▲ or MR/▼ key to select the required cell constant and confirm by pressing ENTER/RANGE. The display then shows the selected cell constant.

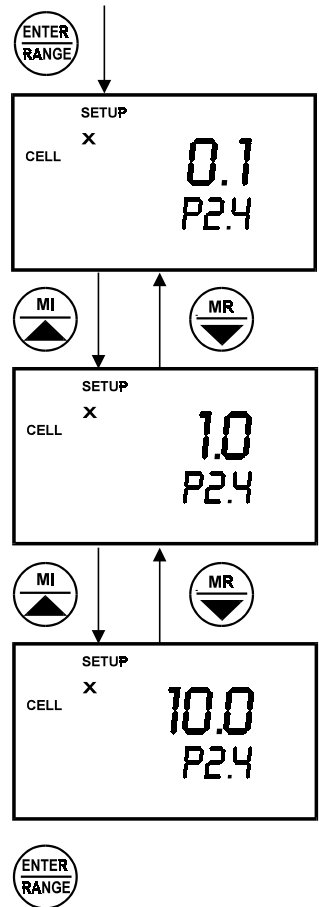

Figure 30: The cell constant selection

8.4 Program 3: TDS Setup (in CyberScan CON 200 only)

8.4.1 P3.0 TDS factor

The TDS factor for a particular standard solution is a multiplication factor which relates the measurement of conductivity in $\mu\text{S}/\text{cm}$ to its equivalent reading in ppm/mg/l. This factor is unique for each solution.

This option allows the selection of the TDS factor for the solution to be measured. The TDS factor is shown on the primary display. Toggle the MI/▲ or MR/▼ key to select the exact TDS factor. The range of values is from 0.4 to 1.0. Any values less than 0.4 or more than 1.0 would cause an error. Press the ENTER/RANGE key to confirm the TDS factor selected. Under default conditions, the TDS factor is set to 0.5.

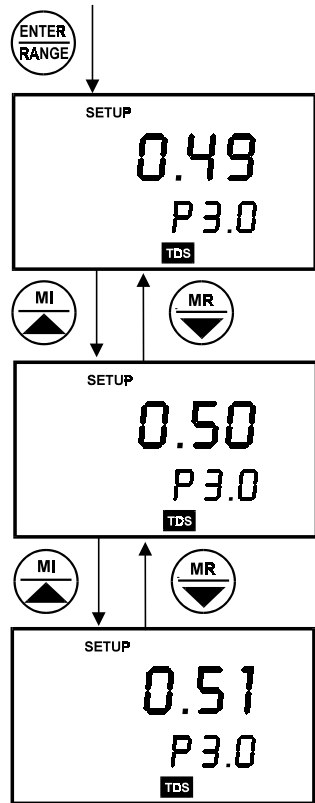

Figure 31: The TDS setup

8.4.2 P3.1: TDS units

In default, the meter shows TDS measurement unit in ppm. To select the TDS measurement in mg/l, toggle the TDS units using the MI/▲ or MR/▼ key. Press enter key to confirm the selection, and the meter scrolls into P4.0.

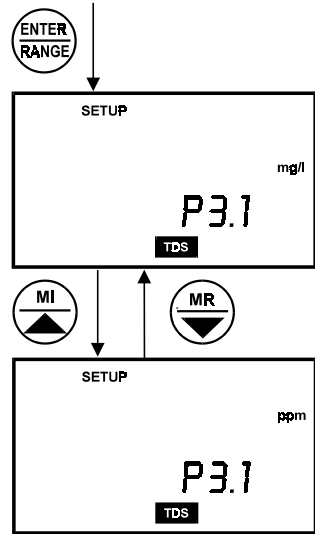

Figure 32: Selecting the TDS unit

8.5 Program 4: Communication Setup (in CyberScan CON 200 only)

This program allows you to set up the instrument's communication parameters of the CyberScan CON 200 meter to enable proper communication with the printer or computer of choice.

8.5.1 P4.0: Baud Rate

You can select a baud rate of 2.4, 4.8, 9.6 or 19.2 kbps (kilo bits per second). Under default conditions, the baud rate is set to 9.6 kbps (9600 bps).

1. From COND or TDS measurement mode, press SET key.
2. Press ENTER/RANGE key until P4.0.
3. Use the MI/▲ or MR/▼ key to change different baud rate.
4. Press ENTER/RANGE key to confirm and continue to set Parity in P4.1.

See figure 33.

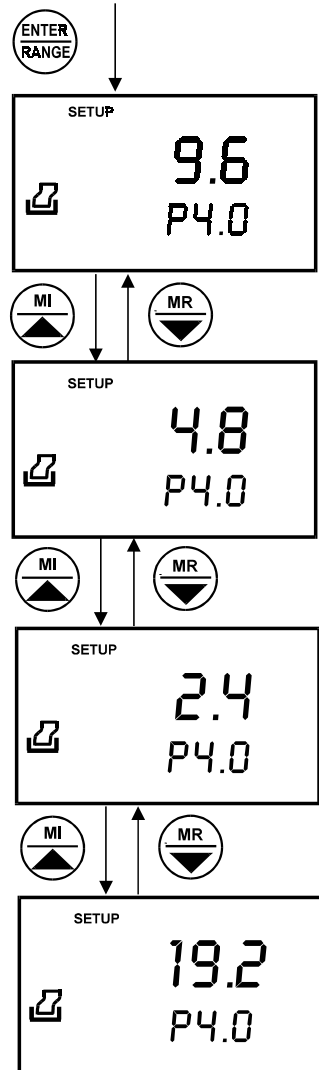

Figure 33: The Baud Rate option

8.5.2 P4.1: Parity

Parity check allows the receiving unit to monitor the integrity of the data that the meter transmits. To accommodate for the variances in standards used, three different parity checks have been provided. They are as shown in the table below. The default parity is even (2).

Value	Parity
0	No parity
1	Odd parity
2	even parity

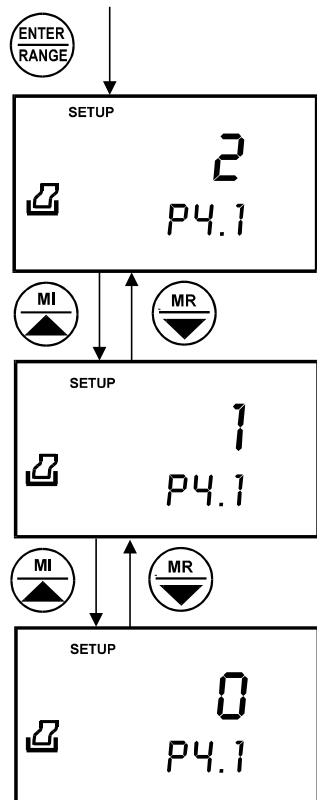

Figure 34: The Parity Check option

8.5.3 P4.2: Stop Bit

The Stop Bit allows the selection of the proper stop bit when transmitting to other peripheral devices (such as printers). You can select the stop bit to be 1 or 2 depending upon the model and make of the peripheral device (the instruction manual of the peripheral device should indicate the number of stop bits used). Under default conditions, the stop bit is 2.

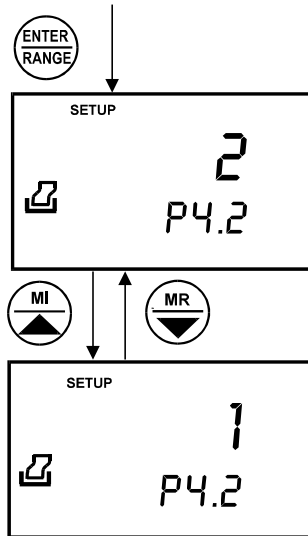

Figure 35: The Stop Bit option

At this point, if the ENTER/RANGE key is pressed, the unit reverts to its measurement mode.

9 CYBERCOMM POTRABLE - DATA ACQUISITION SOFTWARE (DAS FOR CYBERSCAN CON 200 ONLY)

The CyberComm Portable software is designed for Eutech's CyberScan pH 100 and Con 200 meters to allow you a convenient means of capturing data for future analysis using other software program such as LOTUS 123, EXCEL or DBASE in Windows®. Often one finds it cumbersome to record and transfer data from one media to another before the required processing can be done. With the CyberComm Portable, this redundant processing can be eliminated or reduced.

9.1 System Requirements

To run the CyberComm Portable program, the following is required:

1. PC - IBM Compatible XT and above with CD-ROM Drive
2. EGA Monitor and above
3. Windows® Operating System '95 and above
4. Connecting communication RS232C cable

9.2 Loading CYBERCOMM PORTABLE

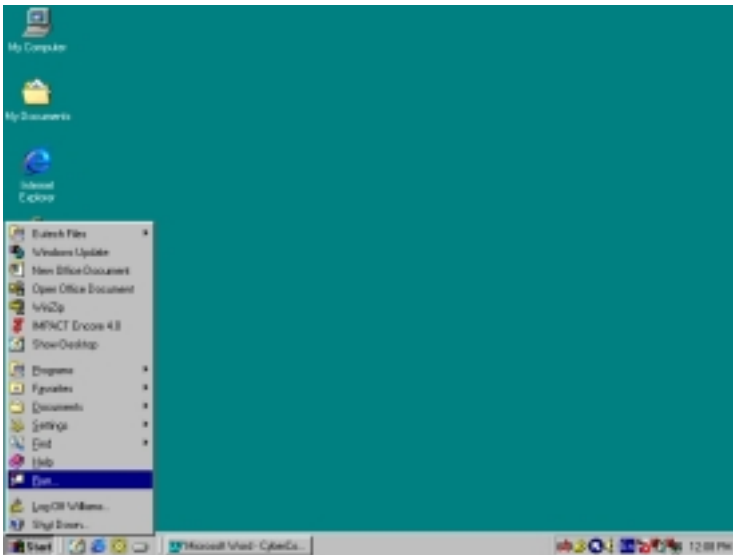

Figure 36: Insert Eutech Instruments' CD-ROM containing Data Acquisition Software (DAS) into your CD-ROM drive and click on START button and RUN command.

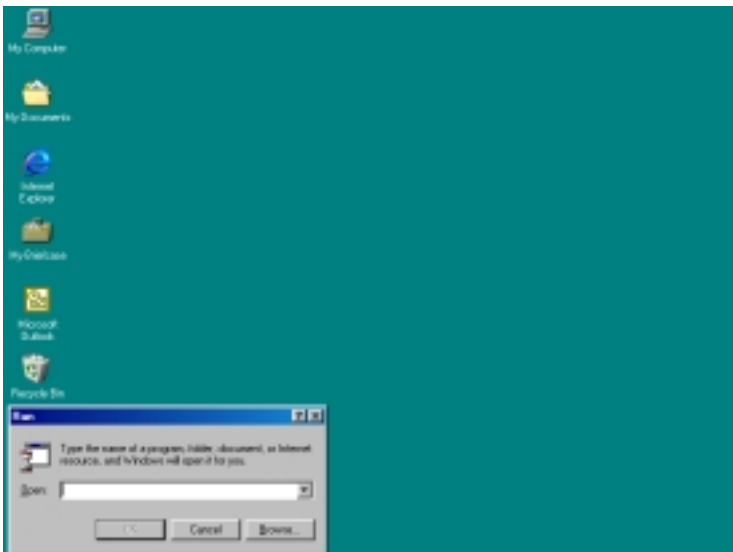

Figure 37: Click on 'Browse' button and locate CD-ROM drive

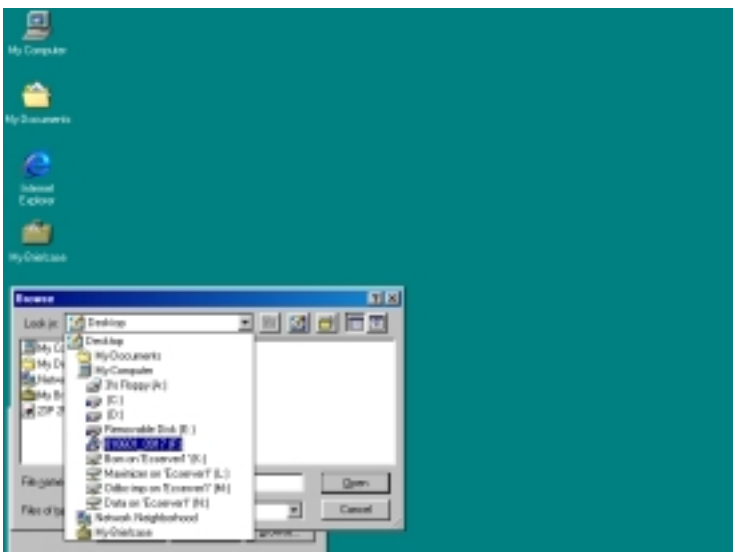

Figure 38: Locate the CyberComm Portable Setup program in the CD-ROM under "CyberComm Portable" sub-directory.

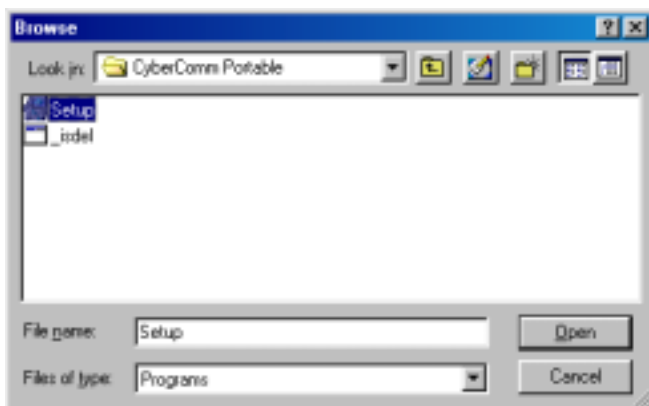

Figure 39: Select "Setup" program and click the OPEN button.

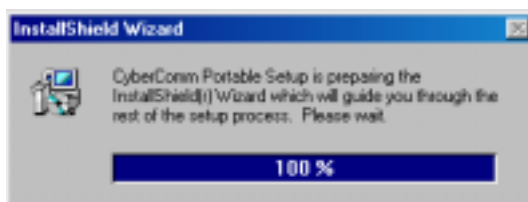

Figure 40: InstallShield Wizard dialog box appears.

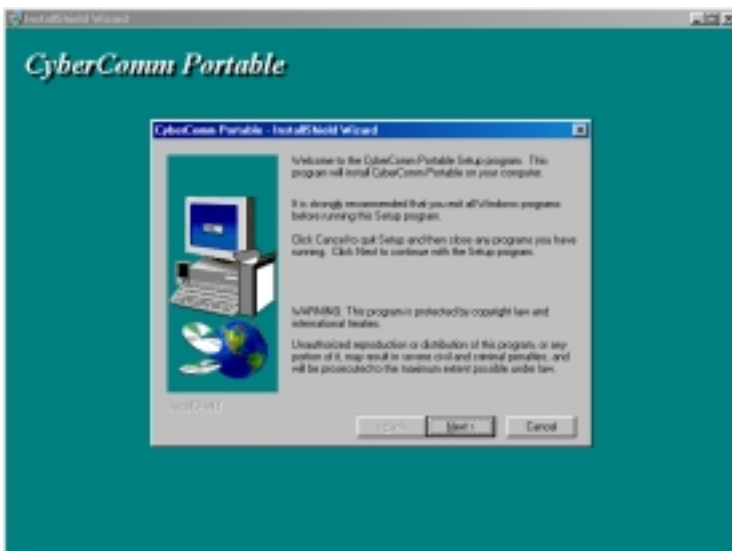

Figure 41: Click on Next button.

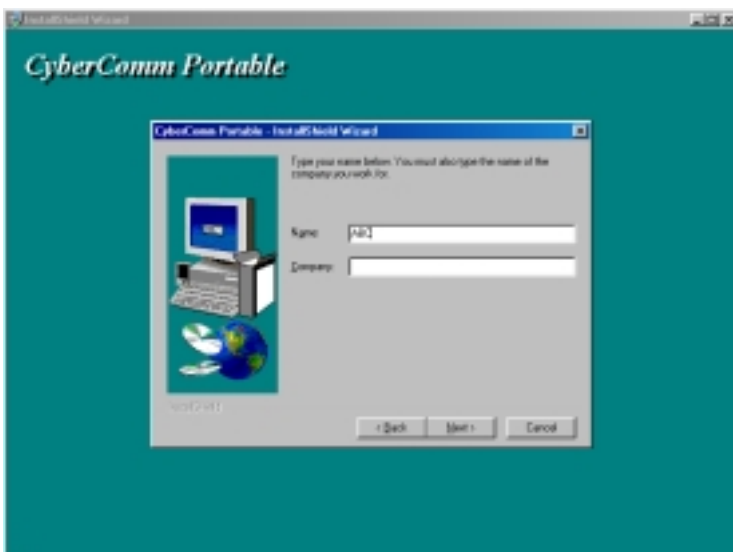

Figure 42: Key in your name and company name and click NEXT button.

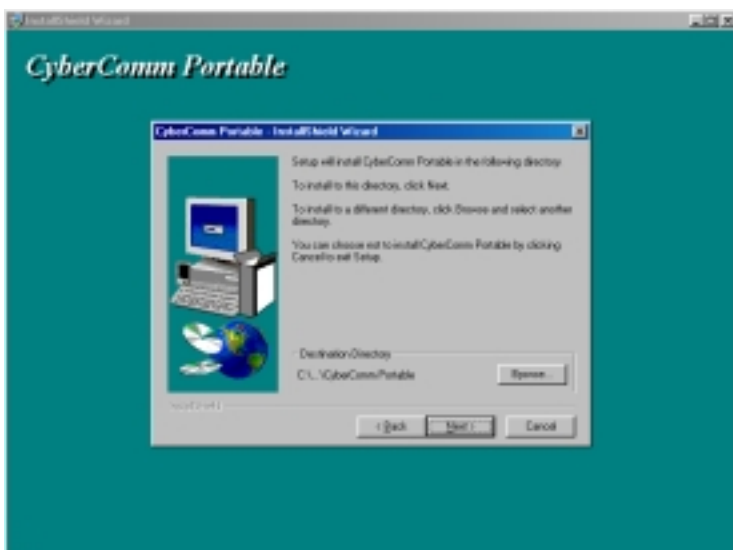

Figure 43: To select another Destination Directory to install the program, click on BROWSE button. Otherwise, click NEXT button.

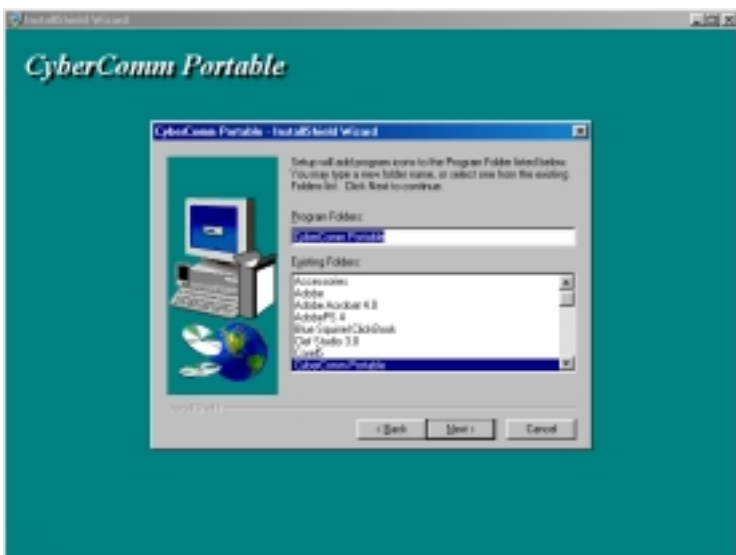

Figure 44: Creating a new program folder. Click on NEXT button.

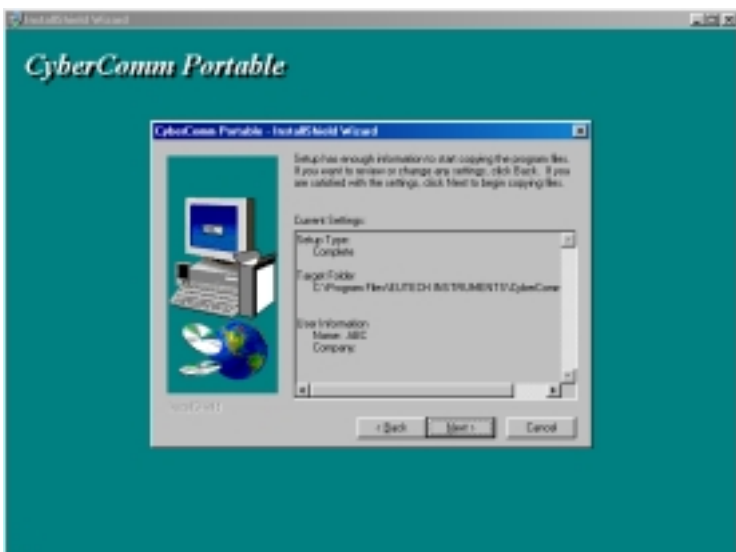

Figure 45: Click on NEXT button.

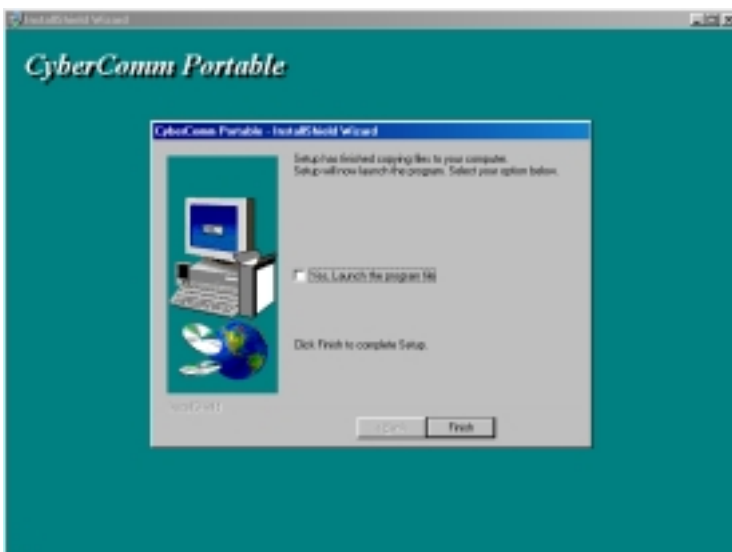

Figure 46: The CyberComm Portable DAS program is fully installed. Click on FINISH button to end installation.

9.3 Running CyberComm Portable

Before running the CyberComm Portable program, please ensure that the RS232 cable is connected between the computer's serial port and the meter's port.

A 1-meter RS232 cable, 9-pin male to 9-pin female connector (order no. EC-CA01M09F09) is supplied with the CyberScan CON 200 meter.

For additional information on the connection, please refer to section 3.5 "Connecting the RS232C cable (only for CyberScan Con 200)".

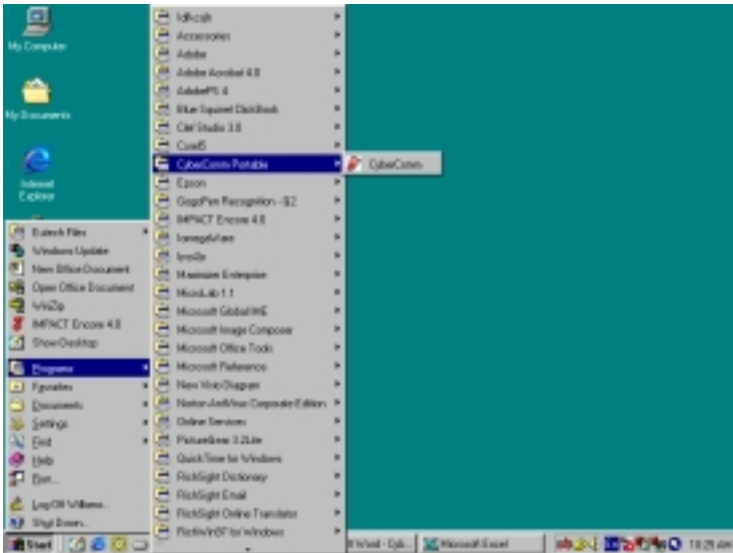

Figure 47: Run the CyberComm Software program

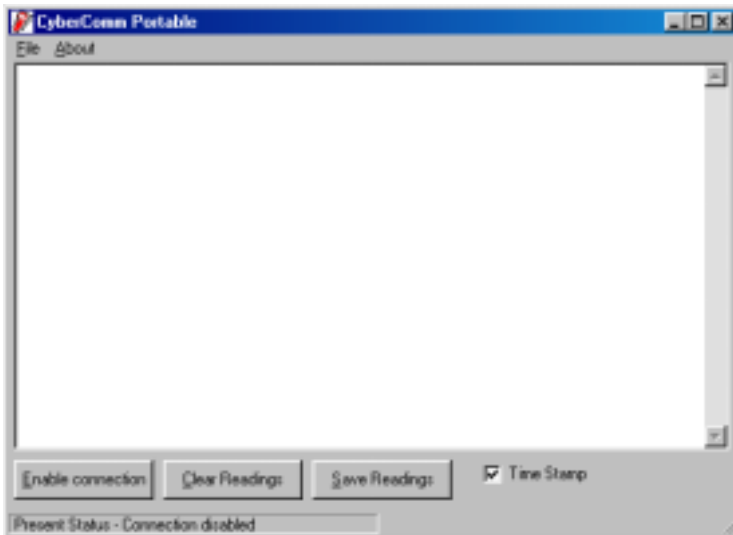

Figure 48: The opening screen will appear as above.

BUTTONS & CHECK-BOX

- **Enable Connection** – Click this button to enable communication between meter and computer
- **Clear Readings** – To clear all data and start all over again
- **Save Readings** – To save all data displayed in either *.dat or *.txt format.
- **Time Stamp** – To include Time and Data stamp when collecting the data. Time and date information comes from the computer.

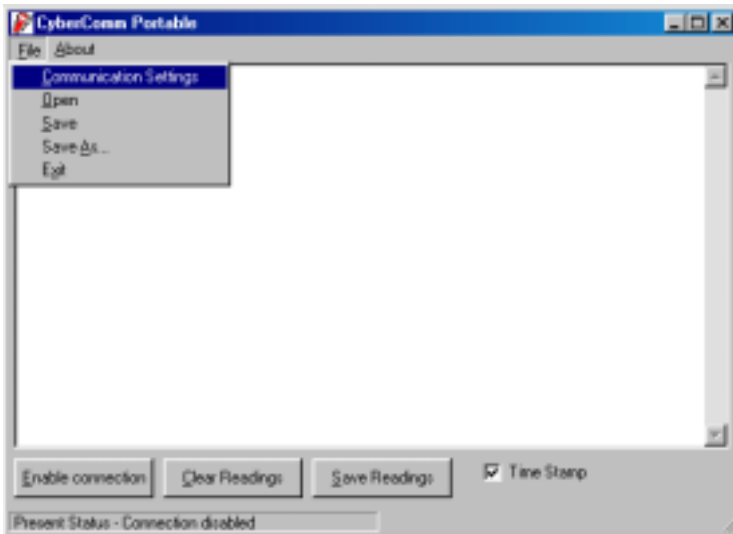

Figure 49: Under File Menu setting, you can change various parameters. Under ABOUT menu, details of Eutech Instruments' contact information, email address and updates are shown.

MENU

- **Communication Settings** – To set communication port number, baud rate speed, parity and stop bits protocol
- **Open** – To open previously saved data file
- **Save** – To save current data captured
- **Save As** – To save current data set in another format such as *.dat or *.txt
- **Exit** – To exit from CyberComm DAS program

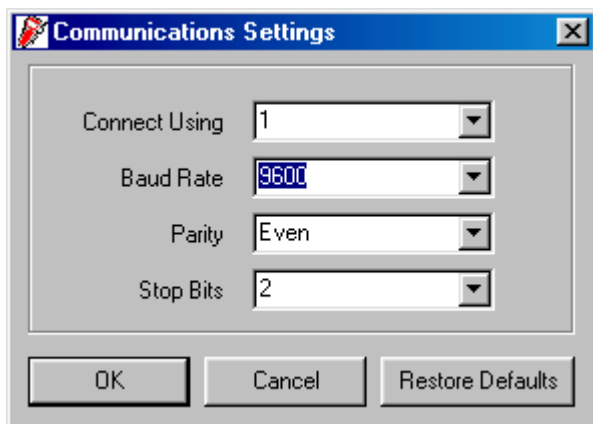

Figure 50: Communication Settings for computer's Com port. It must match with COM port settings on CyberScan CON 200 meter. Please refer to Section 3.5.1 "RS232C Configuration" for the settings.

COMMUNICATION SETTINGS

- **Connecting Use** - To select communication port, 1 or 2.
- **Baud Rate** - To select different baud rate, 2400, 4800, 9600 or 19200 bps (bits per second).
- **Parity** - To select different parity, Even, Odd or None.
- **Stop Bits** - To select different stop bits, 1 or 2.

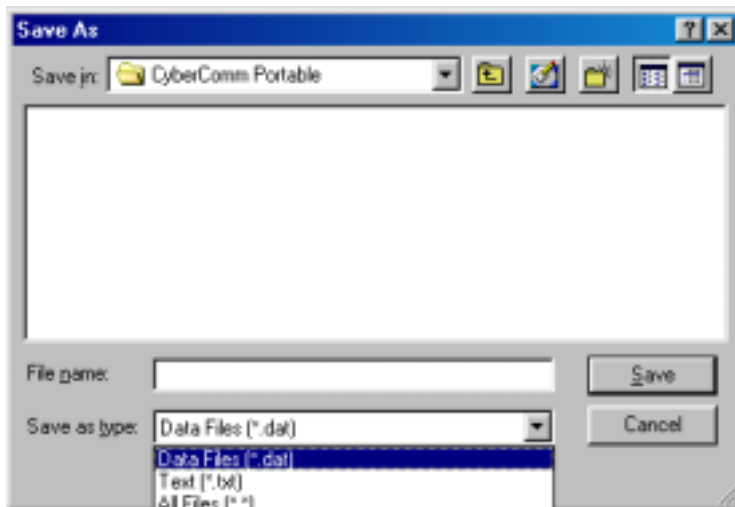

Figure 51: Under SAVE AS menu, you can save your data as *.dat or *.txt formats

9.4 Capturing And Printing Data Into Computer Using CyberComm Portable

After matching the Communication Settings between your computer using CyberComm DAS and the CyberScan CON 200 meter, you can now capture data into your computer for analysis and storage purposes.

1. Ensure the 1-meter RS232 communication cable (supplied with the meter) is connected between the computer and the CyberScan CON 200 meter's Com port. Refer to section 3.5 "Connecting the RS232C Cable (Only For CyberScan CON 100)" for connection procedure.
2. Switch on the CyberScan CON 200 meter and run the CyberComm DAS software as indicated in Figures 47 and 48.
3. Click "ENABLE CONNECTION" button.
4. With the CyberScan CON 200 meter switched on, press the PRINT key to send data to the computer. See Figure 52 below.
5. You can use MODE key on the meter and change to other parameter such as mV or Rel mV and print data accordingly.
6. You can also check off the Time Stamp function, so as to print without the Time and Date information.
7. You can click Clear Readings button to begin another set of measurements, or click Save Readings to store readings for future retrieval.

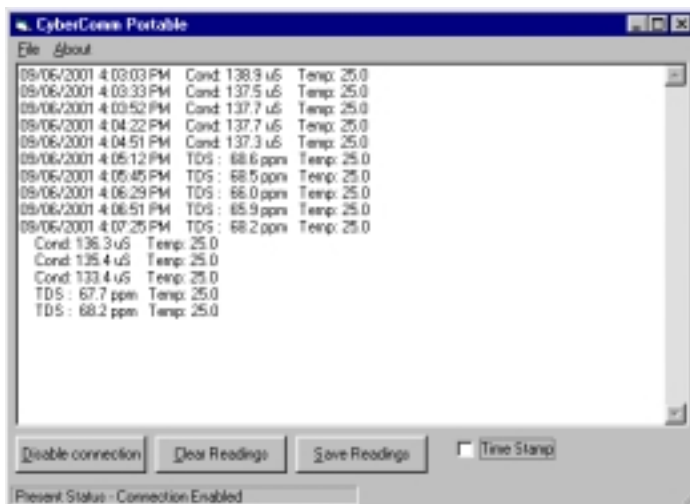

Figure 52: A set of data print in CyberComm Portable DAS

9.5 Troubleshooting Guide

a) Problem: Unable to PRINT

When press PRINT key on the CyberScan CON 200 meter, the “Print” and “Err” annunciators blink on the meter’s LCD screen as shown in Figure 53.

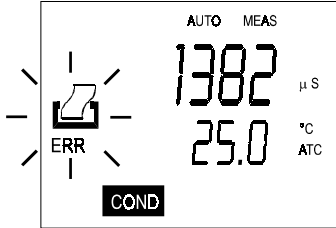

Figure 53: "Print" and "Err" icons blinking

POSSIBLE CAUSES	SOLUTIONS
You have not "ENABLE CONNECTION" in the CyberComm DAS program.	Click on "ENABLE CONNECTION" in the CyberComm DAS program.
The "Communication Settings" in the CyberComm DAS program is different from meter's setup.	Match the COM port number, baud rate, parity and stop bits information between the CyberComm DAS program and the meter.
The COM port number in the CyberComm DAS program is wrong.	Change the COM port number (1 or 2) in the CyberComm DAS program.
Your computer's COM port setting may be wrong.	Check your computer's hardware settings (through Windows OS, BIOS, or any other OS) and refer to computer's manual or consult with the computer's manufacturer.
You may use the wrong communication cable.	Make sure you use the RS232C cable supplied together with the meter (Part No. EC-CA01M09F09). Check the RS232C configuration as described in the meter's instruction manual.

b) Problem: Unusual characters appear in data

When press PRINT key on the CyberScan CON 200 meter, additional characters such as the following appear.

06/18/2001 1:48:38 PM? Cond? -900? Temp: ?22.6

POSSIBLE CAUSES	SOLUTIONS
The Baud rate, parity or stop bit information are not matched.	Check the communication setup for both CyberComm DAS program and meter and ensure both are the same.

To report any bugs, please e-mail to techsupport@eutechinst.com

10 TROUBLESHOOTING & ELECTRODE CARE

10.1 Troubleshooting

ERROR MESSAGE (BLINKING)	INDICATES	PROBABLE CAUSE	CORRECTIVE ACTION
ERR	Invalid key sequence	Wrong key press.	Select correct key
ERR	Upper/lower limit reached	INC/DEC keys presses beyond the allowable limits.	Reselect parameter within limits
CAL + ERR	Unable to accept calibration	<ol style="list-style-type: none"> 1. Incorrect solution conductivity/TDS value entered. 2. Incorrect TDS factor entered. 	<ol style="list-style-type: none"> 1. Enter the correct TDS or conductivity value (note the temperature of the calibration solution). 2. Enter the correct TDS factor.
PRINTER + ERR	Printing error	<ol style="list-style-type: none"> 1. Printer is not ready or unable to receive data. 2. Printer is improperly connected. 	<ol style="list-style-type: none"> 1. Ensure that printer is set to receive information. Check also the SETUP data communication settings. 2. Check the RS 232C port cable connection.
Unable to switch on	Battery problem	<ol style="list-style-type: none"> 1. Batteries not in place. 2. Incorrect battery orientation. 3. Weak batteries. 	<ol style="list-style-type: none"> 1. Insert batteries. 2. Place the batteries at the correct orientation. 3. Replace with fresh batteries or use A.C. adapter.

ERROR MESSAGE (BLINKING)	INDICATES	PROBABLE CAUSE	CORRECTIVE ACTION
Incorrect readings		<ol style="list-style-type: none"> 1. Incorrect calibration. 2. Wrong temperature coefficient %. 3. Wrong TDS factor. 4. Dirty electrode. 	<ol style="list-style-type: none"> 1. Reset calibration and re-calibrate with correct parameters. 2. Reset Temperature compensation %. 3. Reset TDS factor. 4. Clean electrode in isopropanol. If electrode is coated with contaminants, clean using soft tissue and re-calibrate.
Not responding to key press		<ol style="list-style-type: none"> 1. HOLD mode selected. 2. Internal program error. 	<ol style="list-style-type: none"> 1. Cancel HOLD mode. 2. Re-insert batteries.
Err 1	Memory write error		Return to distributor for repair or replacement.
Err 2	Memory read error		Return to distributor for repair or replacement.
Err 3	A/D error		Return to distributor for repair or replacement.
Err 4	Keypad error		Return to distributor for repair or replacement.
Err 5	EEPROM read error		Return to distributor for repair or replacement.

10.2 Electrode Care

The most important rule to follow is to always keep the electrode clean to ensure accurate measurements. Always take care not to damage the cell.

For general cleaning, the use of de-ionized water will be sufficient. Rinse the electrode thoroughly in the de-ionized water. After cleaning, wipe the electrode dry. Never touch the sensors.

For intensive cleaning, when the electrode is contaminated, wash it carefully with isopropanol, after which wash thoroughly with de-ionized water. Always ensure that there is no blockage of the electrode cavity. If there is, use a gentle jet of water to dislodge any particles that may have been stuck there.

Important

Never leave the electrode immersed in dilute or concentrated acids after taking measurements. Quickly remove the electrode and rinse with de-ionized water thoroughly.

Short period storage: For storage of electrode over short periods, dry the electrode and store it in a cool place.

Long period storage: Clean the electrode thoroughly with de-ionized water and dry it. Disconnect the electrode from the meter and store it in a cool place.

11 ADDITIONAL INFORMATION

What is Conductivity?

In general, conductivity is a value that represents how easily electrical charges can be transported through a conductor. Conductors are substances that permit the movement of electrical charge with relative ease.

Figure 39 shows a conductivity cell. It is an electrochemical cell for measuring the conductivity of an electrolyte solution. This cell consists of two electrodes; an anode and a cathode, separated by an electrolyte solution. The two electrodes are in the shape of plates of identical size, both having an identical surface area of $A \text{ cm}^2$. They are aligned parallel and are separated by the distance, L . The space between them is filled completely with water-soluble electrolyte solution. Alternating current flows through both electrode plates.

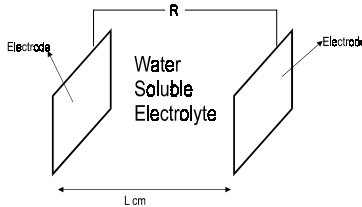

Figure 54: Conductivity cell. An electrochemical cell for measuring conductivity.

The negatively charged ions (anions) in the electrolyte migrate towards the anode and the positively charged ions (cations) move towards the cathode. The result is the flow of electrical current by ion movement.

The resistance to the movement of the charge between the two electrodes is inversely proportional to their surface area and in direct proportion to their surface and also in direct proportion to the distance between them. This is true for both electron movements in the metal electrodes and ion movement in electrolytes. This relationship may be expressed by the equation below.

$$R = r \cdot (L/A) = r \cdot k \quad \text{Equation 1}$$

Where

R = the resistance in ohms (Ω)

r = the resistivity ($\Omega\text{-cm}$)

A = the surface area of the electrode (cm^2)

L = the distance between the electrodes (cm)

k = the cell constant (cm^{-1})

The resistivity **r** is the index of how difficult it is for the current to flow through the solution. This is a constant, determined for each electrolyte. The reciprocal of **r** is called the conductivity, **C**, where **C**= $1/r$.

(In electrochemical terms, the conductivity is proportionally constant of the electrolyte, which is an intrinsic property of the solution; and **C** is the conductance, the inverse of resistance for a certain segment of the electrolyte).

However, we can use the terms conductance and conductivity interchangeably as an index of how easily current can flow through an electrolyte, and **C** will be referred to as the conductivity. This is an accepted general practice.

C is expressed in units of Siemens (S ohms^{-1}) per cm (S/cm). Using **C**, equation 1 can be reformulated as equation 2.

$$R=k/C \quad \text{Equation 2}$$

From equation 2, it is clear that we have a conductivity cell with a cell constant, **k** of 1 (i.e. 1 cm^{-1}), then the inverse of the electrode resistivity, **R**, (in ohms) will be the conductivity, **C**, in S/cm .

A conductivity cell with a cell constant of 1 is defined as an electro-chemical cell where each of the electrode plates has a surface area of 1 cm^2 and the electrodes are aligned in parallel and separated by a distance of 1 cm.

Conductivity can be defined in this way; however, since it will fluctuate depending on the temperature of the electrolyte, in general, conductivity is specified at a standard reference temperature of $25 \text{ }^\circ\text{C}$.

Since the conductivity of the electrolyte is based on ion movement, it is natural that the concentration of ions in the solution will have a great bearing on this. Therefore, the conductivity can provide us with valuable indicators in gathering data on the nature of the ions in the solution. The results of conductivity measurements are widely used in the electrochemical field.

12 ACCESSORIES AND CALIBRATION BUFFER SOLUTIONS

12.1 Replacement Meter and Meter Accessories

Ordering Code No.	Item
EC-CON200/03N	Deluxe CyberScan CON 200 Portable Conductivity/TDS Meter with RS232C Communication Interface and 16 memory ($\mu\text{S}/\text{cm}$, mS/cm ; ppm, ppt, $^{\circ}\text{C}$) complete with 1 pc of conductivity electrode (EC-CONSEN21B), 1 pc of electrode holder (15X000700), 1 pc of communication cable (EC-CAO1M09F09) and 1 pc of Data Acquisition Software in CD-ROM (EC-DA-2000).
EC-CON100/03	Standard CyberScan CON 100 Portable Conductivity Meter with 16 memory ($\mu\text{S}/\text{cm}$, mS/cm ; $^{\circ}\text{C}$) complete with 1 pc of conductivity electrode (EC-CONSEN21B) and 1 pc of electrode holder (15X000700).
EC-CON10/03N	Basic CyberScan CON 10 Portable Conductivity /TDS Meter ($\mu\text{S}/\text{cm}$, mS/cm ; ppm, ppt, $^{\circ}\text{C}$) complete with 1 pc of conductivity electrode (EC-CONSEN41B) and 1 pc of electrode holder (15X000700).
EC-CONSEN21B (For CyberScan CON 100/200)	Epoxy body conductivity electrode ($k=1.0$) with 2 platinum rings and built-in temperature sensor, 1 m cable length.
EC-CONSEN41B (For CyberScan CON 10)	Epoxy body conductivity electrode ($k=1.0$) with 2 stainless steel pins and built-in temperature sensor, 1 m cable length.
EC-CONSEN71B (For CyberScan CON 100/200)	Epoxy body conductivity electrode ($k=0.1$) with 2 platinum rings and built-in temperature sensor, 1 m cable length.
EC-CONSEN81B (For CyberScan CON 100/200)	Epoxy body conductivity electrode ($k=10.0$) with 2 platinum rings and built-in temperature sensor, 1 m cable length.
EC-CAO1M09F09	CyberScan to PC communication cable - 9-pin male to 9-pin female connector, 1 m cable length.
EC-DA-2000	DAS (Windows [®] version – CyberComm Portable) for CyberScan pH 100 & CON 200 & DAS for Bench meters.
EC-CONWP-KIT	Conductivity Kit for CON 10/100/200 Meter - Plastic Carrying Case comprises of 1 x 1413 μS , 12.88 mS KCl and 3000 ppm442 standard solutions (60 ml) and 1 x rinse/waste water bottle (480 ml – empty).
EC-POUCH-02	Carrying pouch for CyberScan hand-held meters.
EC-120-ADA	120 VAC power adapter (120 VAC/9 VDC, 50/60 Hz), 2-pin type.
EC-220-ADA	220 VAC power adapter (220 VAC/9 VDC, 50/60 Hz), 2-pin type.

12.2 Calibration Solutions

Ordering Code No.	Item
EC-CON-100BT	100 μ S KCl Calibration Solution *, 480 ml bottle.
EC-CON-500BT	500 μ S KCl Calibration Solution, 480 ml bottle.
EC-CON-1413BT	1413 μ S KCl Calibration Solution, 480 ml bottle.
EC-CON1288BT	12.88 mS KCl Calibration Solution, 480 ml bottle.
EC-CON2764BT	2764 μ S KCl Calibration Solution, 480 ml bottle.
EC-442-50BT	50 ppm 442 Calibration Solution *, 480 ml bottle.
EC-442-300BT	300 ppm 442 Calibration Solution, 480 ml bottle.
EC-442-1000BT	1000 ppm 442 Calibration Solution, 480 ml bottle.
EC-442-3000BT	3000 ppm 442 Calibration Solution, 480 ml bottle.
EC-CON-447BS	447 μ S conductivity Sachets, 20 ml x 20 pcs.
EC-CON-1413BS	1413 μ S Conductivity Sachets, 20 ml x 20 pcs.
EC-CON-2764BS	2764 μ S Conductivity Sachets, 20 ml x 20 pcs.
EC-CON-15000BS	15000 μ S Conductivity Sachets, 20 ml x 20 pcs.

*Note: Shelf Life for Calibration Solutions is 3 years (otherwise 1 year as marked *)*

13 SPECIFICATIONS OF CYBERSCAN CON 10/100/200

Models	CON 10	CON 100	CON 200
Conductivity range	0 to 19.99, 199.9, 1999 μ S/cm; 19.99 mS/cm	0 to 19.99, 199.9, 1999 μ S/cm; 19.99, 199.9 mS/cm	
Accuracy	\pm 1% Full Scale		
Resolution	0.05% of Full Scale		
TDS range	0 to 9.99, 99.9, 999 ppm; 9.99 ppt		0 to 9.99, 99.9, 999 ppm; 9.99, 99.9, 199 ppt
Resolution	0.01, 0.1, 1 ppm; 0.01 ppt		0.01, 0.1, 1 ppm/ppt
Temperature range	0.0 to 100.0 $^{\circ}$ C		
Accuracy	\pm 0.5 $^{\circ}$ C		
Resolution	0.1 $^{\circ}$ C		
TDS factor	0.5		0.40 to 1.00 (selectable)
No. of calibration points	4, maximum 1 per range	5, maximum 1 per range	
Auto-ranging capability	Yes		
Averaging/stability	Yes		
Auto-off	Yes		
Memory		16 sets	
User customization		Yes	
HOLD function	Yes		
Cell constant	1.0	0.1, 1.0 & 10.0	
Temperature coefficient	2 % per $^{\circ}$ C	0.0 to 10 % per $^{\circ}$ C (selectable)	
Temperature compensation	Auto/manual (from 0 to 80 $^{\circ}$ C)		
Display	Custom LCD		
Inputs	BNC, phono, power jack		
Printing option			Yes
Outputs			RS 232 port/printer
Power	4 AAA batteries; 9 V DC adapter		
Battery life	> 200 hours		

14 WARRANTY & RETURN OF ITEMS

Eutech Instruments warrants this meter to be free from significant deviations in material and workmanship for a period of three years from date of purchase. Eutech Instruments warrants this probe to be free from significant deviations in material and workmanship for a period of six months from date of purchase. Each instrument will have a warranty card with a specific serial number. The warranty card must be endorsed by the Authorized Distributor at the point of sale.

If repair or adjustment is necessary and has not been the result of abuse or misuse within the designated period, please return – freight pre-paid – and correction will be made without charge. Eutech Instruments alone will determine if the product problem is due to deviations or customer misuse.

Out of warranty products will be repaired on a charged basis.

Exclusions

The warranty on your instrument shall not apply to defects resulting from:

- Improper or inadequate maintenance by customer
- Unauthorized modification or misuse
- Operation outside of the environment specifications of the products

Return of items

Authorization must be obtained from our Customer Service Department or authorized distributor before returning items for any reason. A “Return Goods Authorization” (RGA) form is available through our authorized distributor. Please include data regarding the reason the items are to be returned. For your protection, items must be carefully packed to prevent damage in shipment and insured against possible damage or loss. Eutech Instruments will not be responsible for damage resulting from careless or insufficient packing. A restocking charge will be made on all unauthorized returns.

NOTE: Eutech Instruments Pte Ltd reserves the right to make improvements in design, construction, and appearance of products without notice.

For more information on Eutech Instruments products, contact your nearest Eutech Instruments distributor or visit our website listed below:

Manufactured by:
Eutech Instruments Pte Ltd.

Blk 55, Ayer Rajah Crescent,
#04-14/24 Singapore 139949
Tel: (65) 6778 6876
Fax: (65) 6773 0863
E-mail: marketing@eutechinst.com
Web-site: <http://www.eutechinst.com>

Distributed by: