

Instruction Manual

CyberScan pH 10 & pH 100

Hand-held pH / mV / Temperature / RS 232 Meter



pH 10 Meter
pH/mV/°C

pH 100 Meter
pH/mV/°C/RS 232



ISO 9001
CERTIFIED

EUTECH
INSTRUMENTS

Technology Made Easy ...

68X007106

09/2001 rev 4

PREFACE

This manual serves to explain the use of the Standard CyberScan series hand-held meters. The models covered are the CyberScan pH 10 and the CyberScan pH 100 hand-held meters.

The manual functions in two ways, firstly as a step by step guide to help the user operate the meter. Secondly, it serves as a handy reference guide.

This instruction manual is written to cover as many anticipated applications of the CyberScan pH meters as possible. If there are doubts in the use of the CyberScan pH 10/100 meters, do not hesitate to contact the nearest Eutech Instruments Authorized Distributor.

Eutech Instruments cannot accept any responsibility for damage or malfunction to the meter caused by improper use of the instrument.

Remember to fill in the guarantee card and mail it back to your authorized distributor or Eutech Instruments Pte Ltd (address, contact details, email and homepage information are found on the back page of this manual).

The information presented in this manual is subject to change without notice as improvements are made, and does not represent a commitment on the part of the Eutech Instruments Pte Ltd.

Note: Lotus® 1-2-3 is a registered trademark of Lotus Corporation.

Excel ® is a registered trademark of Microsoft Corporation.

Copyright ©1993 Eutech Instruments Pte. Ltd. All rights reserved.

Revised in September 2001, revision 4 (version 5).

TABLE OF CONTENTS

1	INTRODUCTION	1
2	DISPLAY AND KEYPAD FUNCTIONS	2
2.1	Display	2
2.2	Keypad	3
3	PREPARATION	5
3.1	Inserting the Batteries	5
3.2	Connecting the pH Electrode, Temperature Probe & Electrode Holder	6
3.3	Connecting the AC/DC Adapter	8
3.4	Connecting the RS232C Cable (Only For CyberScan pH 100)	9
4	CALIBRATION	11
4.1	Preparing the Meter for Calibration	11
4.2	pH Calibration with ATC	12
4.3	pH Calibration (without ATC)	14
4.4	Temperature Calibration	15
4.5	Calibration Procedure for Relative mV Measurements (For pH 100 Only)	17
4.6	Erasing Calibrated Values (For pH 100 only)	18
5	MEASUREMENT	19
5.1	Automatic Temperature Compensation	19
5.2	Manual Temperature Compensation	20
5.3	Taking Measurements	21
6	HOLD FUNCTION	22
7	MEMORY FUNCTION (FOR pH 100 ONLY)	23
7.1	Memory Input	23
7.2	Memory Recall	24
8	PRINT FUNCTION (FOR pH 100 ONLY)	25
8.1	Using the CyberScan pH 100 With The Printer	25
8.2	Sending Data To Computer	26
9	ADVANCED SETUP FUNCTIONS (FOR pH 100 ONLY)	28
9.1	Program 1 – Software Initialization	29
9.2	Program 2 – Electrode Data	30
9.3	Program 3 –Meter Configuration	32
9.4	Program 4 – Communication Setup	34
10	CYBERCOMM PORTABLE - DATA ACQUISITION SOFTWARE (DAS FOR pH 100 ONLY)	36
10.1	System Requirements	36
10.2	Loading CYBERCOMM PORTABLE	36
10.3	Running CYBERCOMM PORTABLE	42
10.4	Capturing And Printing Data Into Computer Using CYBERCOMM PORTABLE	46
10.5	Trouble-shooting Guide	47
11	ELECTRODE CARE	48
11.1	Electrode Maintenance	48
11.2	Electrode Cleaning	49
11.3	Electrode Activation	49
11.4	Rejuvenation Procedure	49
12	ERROR MESSAGES	51
13	TROUBLE-SHOOTING	52
14	INFORMATION ON pH MEASUREMENT & ELECTRODE	53
14.1	pH Measurements	53
14.2	Use of Standard pH Buffers	54
14.3	Standard pH Buffers	55

15	LIST OF ACCESSORIES	56
15.1	<i>Replacement Meter and Meter accessories</i>	56
15.2	<i>Calibration Solutions</i>	57
15.3	<i>Ion Selective Electrodes (ISE)</i>	57
15.4	<i>pH & ORP Electrodes</i>	58
16	METER SPECIFICATIONS	59
17	ADDENDUM 1: FACTORY DEFAULT SETTINGS (pH 100 ONLY)	60
18	WARRANTY & RETURN OF ITEMS	61

1 INTRODUCTION

Thank you for selecting Eutech Instruments standard CyberScan pH 10/100 meter. These meters are microprocessor-based instrument and are designed to be handy, capable of allowing one-hand operation. Each has a large custom dual LCD for clear and easy reading. It is a unique and intelligent instrument that has the capability to cater to the preferences of the discerning individual.

Both meters have many user-friendly features – all of which are completely accessible through the splash-proof membrane keypad. Your meter includes a temperature probe (EC-PHTEM-01P), electrode holder, built-in meter stand and batteries. Eutech Instruments offer a wide selection of pH and ORP electrodes. Refer to “Accessories” section for more information.

The basic model is the CyberScan pH 10 which is capable of measuring pH, Temperature, and millivolt (mV).

The deluxe model is the CyberScan pH 100 which measures pH, Temperature, millivolt (mV) and relative millivolt (Rel mV). It has many advanced features and allows you to customize the meter settings. It also has a RS232C port that allows the meter to be connected to a computer or a printer via a cable for transferring data.

For power requirement, you can either use 4 AAA-sized batteries or an AC/DC power adapter (sold separately).

Please read this manual thoroughly before operating your meter.

2 DISPLAY AND KEYPAD FUNCTIONS

2.1 Display

The LCD has a primary and secondary display.

- The primary display shows the measured pH or ORP values.
- The secondary display shows the measured temperature.

The display also shows error messages, keypad functions and program functions.

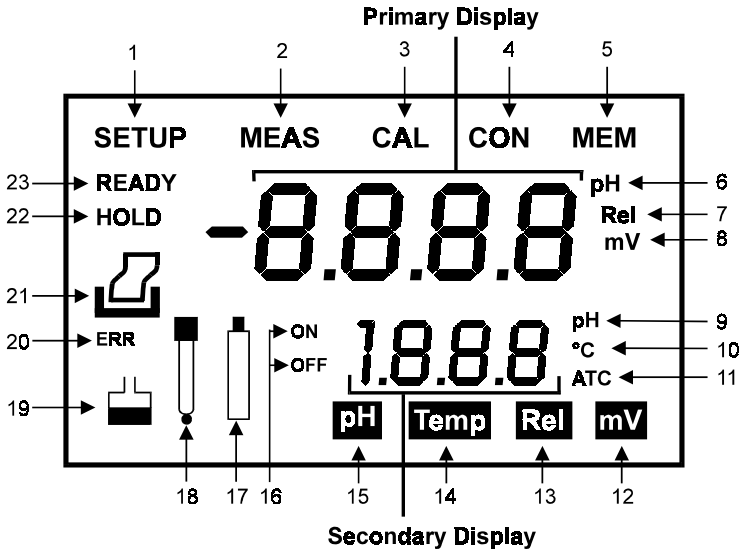



Figure 1: Full LCD Screen

- | | | |
|---|---|---|
| 1. SETUp mode indicator | 9. pH buffer selection indicator | 16. ON & OFF indicator |
| 2. MEASurement mode indicator | 10. Temperature indicator | 17. Low battery indicator |
| 3. CALibration indicator | 11. Automatic Temperature Compensation indicator | 18. Probe indicator |
| 4. CONFirm indicator | 12. mV measurement mode indicator | 19. Buffer indicator |
| 5. MEMory recall mode indicator (For pH 100 only) | 13. Rel mV measurement mode indicator (For pH 100 only) | 20. ERRor indicator |
| 6. pH indicator | 14. Temperature measurement mode indicator | 21. Printer indicator (For pH 100 only) |
| 7. Relative mV indicator (For pH 100 only) | 15. pH measurement mode indicator | 22. HOLD indicator |
| 8. mV indicator | 23. READY indicator | |

2.2 Keypad

A large membrane keypad with tactile feedback makes the instrument easy to use. Each button, when pressed, has a corresponding graphic indicator on the LCD (Figure 1). Some buttons have several functions depending on its mode of operation.

Key	Function
ON/OFF	Powers on and shuts off the meter. The meter will start in pH measurement mode.
HOLD	Freezes the measured reading. To activate, press HOLD while in measurement mode. To release, press HOLD again.
MODE	Selects the measurement parameter. Default is pH measurement. Press MODE to toggle between pH, Temperature, Rel mV (<i>only pH 100</i>), mV, & back to pH measurement mode.
CAL/MEAS	<p>Toggles between Calibration and Measurement mode.</p> <ol style="list-style-type: none"> If you are in pH measurement mode, press CAL/MEAS to enter pH calibration mode. If you are in temperature measurement mode, press CAL/MEAS to enter temperature calibration mode. If you are in Rel mV (<i>only in pH 100</i>) measurement mode, press CAL/MEAS to enter Rel mV measurement calibration mode. <p>While in SETUp (<i>only in pH 100</i>) menu, pressing CAL/MEAS takes you out and into the measurement mode.</p>
CON	CONFirm function: Press to confirm values in Calibration mode and to confirm selections in SETUp mode.
▲ / ▼	<p><u>In Calibration mode:</u></p> <ol style="list-style-type: none"> If you are in pH calibration mode, press ▲ or ▼ key scrolls up or down the buffer calibration values. If you are in temperature calibration mode, press ▲ or ▼ key to adjust temperature values in °C. If you are in Rel mV (<i>only in pH 100</i>) calibration mode, press ▲ or ▼ key to adjust mV values. <p><u>In SETUP mode (only in pH 100):</u> Press ▲ or ▼ key to scroll through options in each SETUp programs.</p>
MI / MR (<i>only in pH 100</i>)	In measurement mode (pH, Rel mV or mV) press MI (memory input) to store values with its corresponding temperature values in the memory. Press MR (memory recall) to retrieve data from memory.
 (<i>only in pH 100</i>)	Allows you to print current measurement to either the printer or the computer.
SETUP (<i>only in pH 100</i>)	Takes you into the SETUP mode. This mode lets you customize meter preference and defaults, view calibration, electrode offset data, clear memory, change pH resolution, and communication protocol setting.

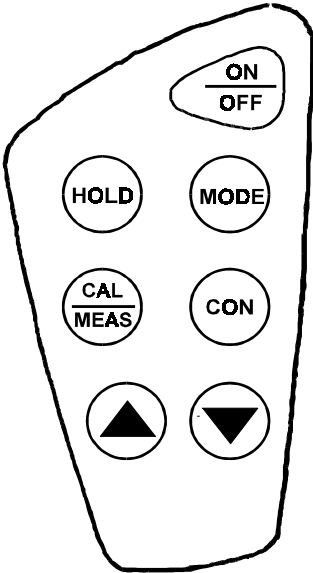

Figure 2: Keypad of pH 10 meter

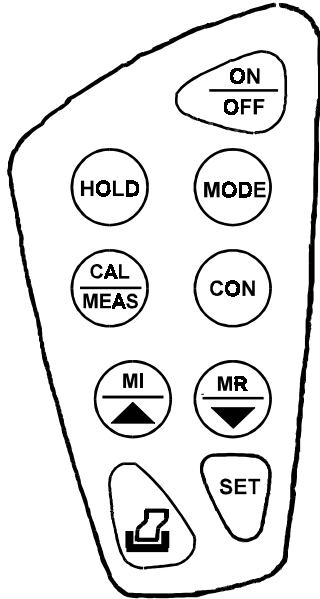

Figure 3: Keypad of pH 100 meter

3 PREPARATION

3.1 Inserting the Batteries

The CyberScan is packaged with 4 “AAA” alkaline batteries required for operation. To insert the batteries into the CyberScan, follow the procedure outlined below.

1. Use a Phillips Head screwdriver, remove the two screws (Figure 4) with the hinge closed.
2. Remove the battery cover. Note the polarity and insert the batteries into the battery compartment correctly (Figure 5).
3. Replace the battery cover into its position and screw back using the two screws removed earlier.

Your CyberScan hand-held meter is now ready for operation.

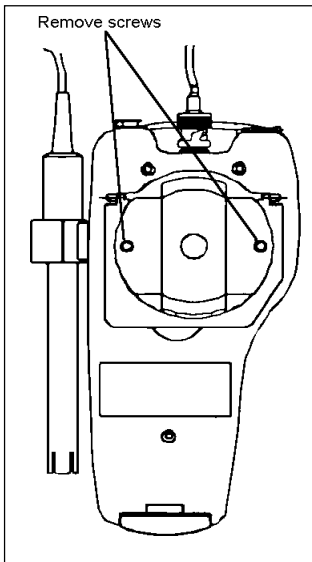

Figure 4: Take out battery cover by removing 2 screws

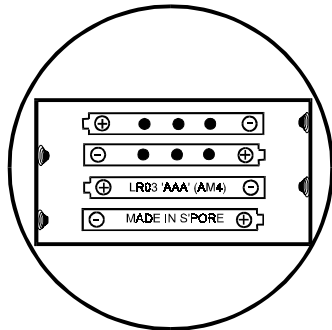

Figure 5: Battery position

3.2 Connecting the pH Electrode, Temperature Probe & Electrode Holder

The Eutech Instruments CyberScan pH 10/100 meter uses any standard pH, ORP, or Ion Selective Electrode (ISE) with a BNC connector. For Automatic Temperature Compensation (ATC), this meter requires a temperature probe with a phono-jack connector.

NOTE: It is important that water does not get onto the BNC connector. Also avoid touching the connector with soiled hands.

3.2.1 To connect pH, ORP or ISE electrode

1. Slide the electrode connector of the electrode over the BNC connector socket on the meter.
2. Make sure the slots of the connector are in line with the posts of the socket.
3. Slide the BNC connector of the probe over (Figure 6).
4. Rotate and push connector clockwise until it locks.
5. To remove electrode, push and rotate the connector anti-clockwise.
6. While holding onto the metal part of the connector, pull it away from the meter.
7. Be careful not to use excessive force.

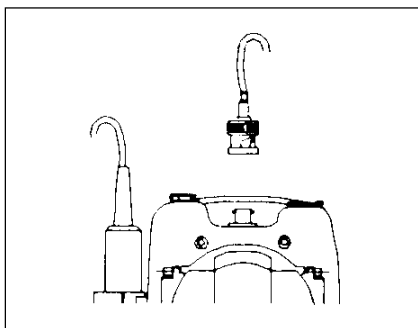

Figure 6: Connect pH or ORP electrode using BNC

CAUTION: Do not pull on the probe cord or the probe wires might disconnect.

Refer to “Accessories” section for information on temperature probe and other electrodes.

3.2.2 To connect the temperature probe:

The temperature probe (provided) uses a phono jack to connect with the socket on the CyberScan. Insert the jack fully into the socket (Figure 7).

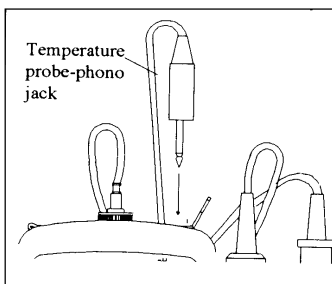

Figure 7: Connecting the temperature probe

3.2.3 Attaching the electrode onto the electrode Holder

The CyberScan pH meter is packed with two electrode holders (provided). They are designed for easy use and installation. Care must be taken to avoid use of excessive force in the process of attaching these components.

1. Locate the slot on the right-hand side of the meter.
2. Gently slide the flange of the holder into the slot on the meter. Make sure the holder is secured properly into the slot (Figure 8).
3. You can attach the electrode holder in different positions (Figure 10).

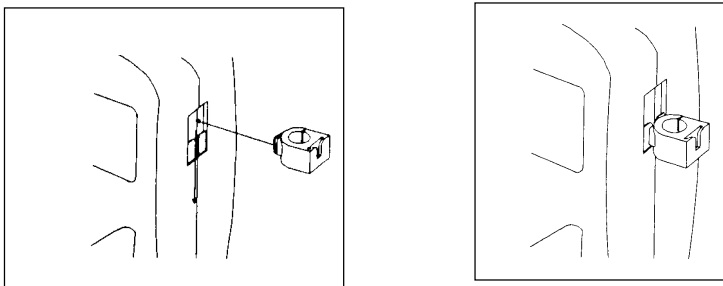

Figure 8: Slide in the electrode holder

3.2.4 To attach a second electrode holder:

The electrode holder is designed such that you can attach one holder onto another. Up to two electrodes (using the BNC connector and phono-jack) can be used with the CyberScan meter at any one time.

1. Align the flange of the second electrode holder with the slot of the first holder (Figure 9).
2. Slide the flange of the second holder into the slot of the first holder until the tops of the holders are aligned and secure.

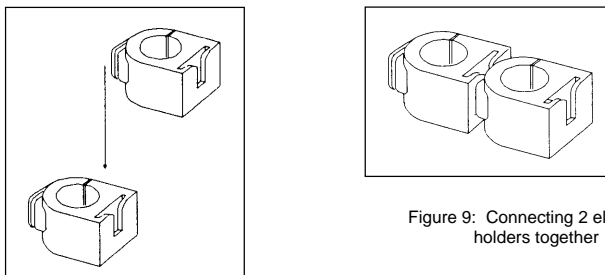

Figure 9: Connecting 2 electrode holders together

3.2.5 Insert the electrode into the holder

1. Do not use excessive force when inserting electrodes into the holders.
2. Insert the pH electrode into the opening of the first holder until the top housing of the electrode touches the top of the holder.
3. If you are using a separate temperature probe, insert the probe into the opening of the second holder until the ridge on the housing touches the top of the holder.

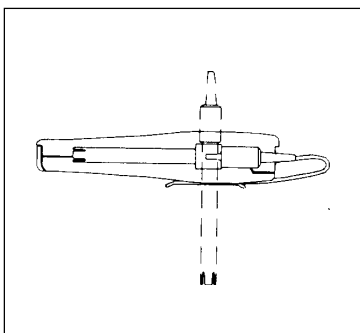

Figure 10: Different positions using electrode holder

NOTE: The holder is designed for probes 12 mm in diameter. Electrodes larger than 12 mm may not fit in the holder. Forcing the electrode into the opening may damage the holder or your electrode.

The electrode holders can be attached in different positions for greater flexibility in measurement and storage purposes. **Simply slide out the electrode holders and reoriented into appropriate orientation before putting into position.**

3.3 Connecting the AC/DC Adapter

Besides using four AAA-sized batteries as power source, the CyberScan pH 10/100 meter can also operate from the power mains using an AC/DC power adapter either at 120/220 VAC (sold separately). This is extremely useful if you have an A.C. power source available (e.g. laboratory).

Before plugging in, switch off the meter and the power source of adapter. This is a safety precaution that should be adhered to safeguard your CyberScan meter.

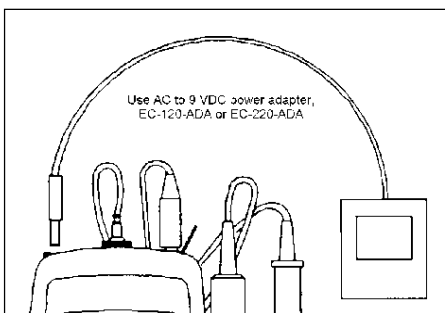

Figure 11: Putting the AC Power Adapter

1. Switch off the meter and power sources.
2. Select the correct voltage of AC/DC Adapter. See Figure 11.

NOTE: Output Voltage: 12 V D.C.; Current: 500 mA. Ensure that the input mains voltage (120/240 VAC) matches your adapter requirements.

3. Insert the D.C. jack into the socket and switch on the power to the adapter, followed by the CyberScan meter.

3.4 Connecting the RS232C Cable (Only For CyberScan pH 100)

The CyberScan pH 100 meter provides a RS232C output for you to transmit your readings either to a printer or a computer via a cable. This is useful in instances where the CyberScan meter is used for continuous monitoring of a certain process or experiment. Data output to the printer or the computer can then be evaluated.

The data is output in the ASCII format. This format allows the data to be imported by a wide variety of software that read ASCII data (e.g. Microsoft's Excel, Lotus, Quattro-pro etc.). Eutech Instruments provides a complimentary Data Acquisition Software (DAS) that captures data transmitted into an ASCII file for later use.

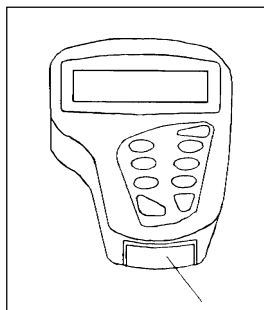

Figure 12: Location of RS232C Port (Only in pH 100)

1. Open the printer port cover located at the bottom end of the meter. Do not use excessive force when doing this. See Figure 12.
2. Noting the orientation of the RS232C connector, plug the male connector into the RS232C port of the CyberScan.
3. Fasten the RS232C connector by fastening the two screws at the side of the male RS232C connector.

3.4.1 RS232C Configuration

The CyberScan pH 100 meter has a 9 pin female RS232C connector with the following pinout:

PIN NO.	DESCRIPTION
1	-
2	Transmit Data
3	-
4	DSR (Data Set Ready)
5	GND
6	-
7	CTS (Clear to Send)
8	-
9	-

A one-to-one connection can be made with a 9 pin RS232C port of the computer.

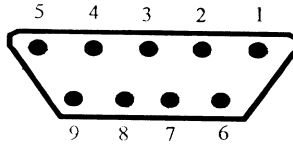

Figure 13: Pin number position of the 9-pin RS 232C port

In case CyberScan pH 100 meter's output has to be sent to a 25 pin RS232C connector, the following cable configuration may be used:

CyberScan pH 100	25 pin connector
2 (TxD)	(RxD) 3
4 (DSR)	(DTR) 20
5 (GND)	(GND) 7
7 (CTS)	(RTS) 4

1. CyberScan pH 100 uses hardware handshake i.e. CyberScan pH 100 expects both DSR and CTS lines to be active before it sends data.
2. If the [PRINT] key is pressed while the printer is not ready or if the printer is off, the CyberScan pH 100 meter displays error message by showing both the printer and the ERR annunciators blinking alternately, and awaits the printer to be ready (Figure 14).
3. While the meter is displaying printer error, you may press CAL/MEAS key to return to the measurement mode.

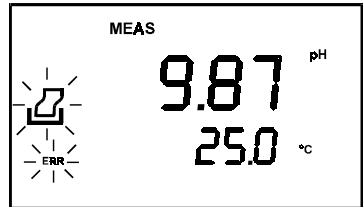

Figure 14: Error in printing

4 CALIBRATION

4.1 Preparing the Meter for Calibration

Before starting calibration, make sure you are in the correct measurement mode. When you switch on the meter, the meter starts up in the pH measurement mode.

Before calibrating, select the correct mode by pressing the MODE key. There are 4 modes:

[pH]	for pH measurements,
[Temp]	for Temperature measurements,
[Rel] [mV]	for Relative mV measurements (<i>only for pH 100 meter</i>)
[mV]	for millivolt measurements.

Be sure to remove the protective electrode storage bottle or rubber cap of the electrode before calibration or measurement. If the electrode has been stored dry, wet the electrode in tap water for 10 minutes before calibrating or taking readings to saturate the pH electrode surface and minimize drift.

Wash your electrode in deionized water after use, and store in electrode storage solution. If storage solution is not available, use pH 4.01 or 7.00 buffer solution.

Do not reuse buffer solutions after calibration. Contaminants in the solution can affect the calibration, and eventually the accuracy of the measurements. Refer to Accessories for information on Eutech Instruments pH buffer solutions.

It is recommended that you perform at least a 2-Point Calibration using standard buffers that adequately cover the expected measurement range prior to measurement. 1-Point Calibration can also be used for quick measurements. Make sure that the calibration point is close to the sample value to be measured.

The CyberScan pH 10 & pH 100 meters are capable of multi-point calibration to ensure enhanced accuracy throughout the pH measurement range. The number of pH calibration points and pH buffer standards used are:

Meter	Number of Calibration Points	Buffer Points (USA standard)
pH 10	Up to 3 points	pH 4.01, 7.00 & 10.01
pH 100	Up to 5 points	pH 1.68, 4.01, 7.00, 10.01 & 12.45

4.2 pH Calibration with ATC

To activate the Automatic Temperature Compensation (ATC), simply plug in the temperature probe into the phono jack. The ATC indicator will be displayed on the LCD (Figure 15). If the ATC indicator is not displayed, it indicates that the temperature probe is either not properly connected to the instrument or is faulty.

1. Switching 'ON' the meter by pressing the ON/OFF key.
2. All the LCD segments will be displayed momentarily for a few seconds to check that all segments are in working condition. Then, the LCD will switch to the [pH] measurement mode.
3. Select the [pH] mode using the MODE key. (See Figure 15 on right).
4. Rinse the electrode well with deionized water or rinse solution. (Do not wipe the electrode with tissue paper as this may cause a build-up of electrostatic charge on the glass surface!).
5. Dip the probe into the calibration buffer. The end of the probe must be completely immersed into the sample. Stir the probe gently to create a homogeneous sample.
6. Press the CAL key to calibrate the meter.
7. The display will show the [CAL] mode and the buffer icon as shown (see [1] & [2] in Figure 15).
8. The primary display will show the measured reading while the secondary display will indicate that pH 7.00 is ready for calibration.
9. Wait for the measured pH value to stabilize. The READY annunciator will light up. See [3] in Figure 15.

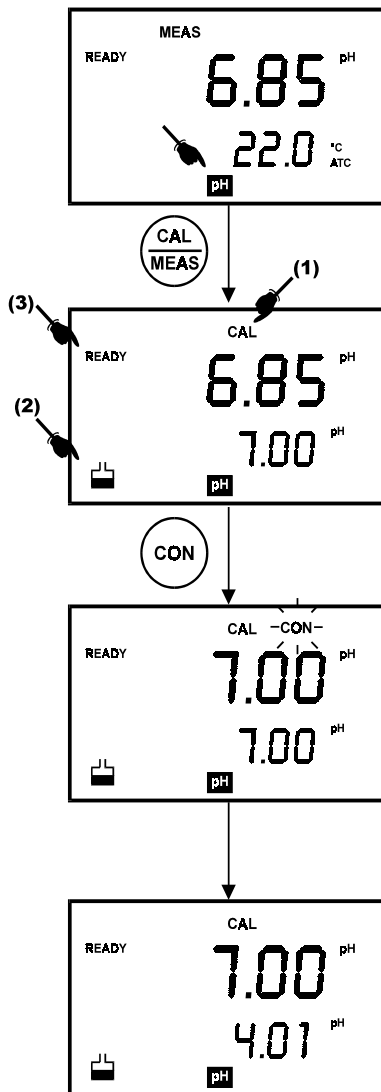

Figure 15: pH Calibration at pH 7.00

NOTE: In pH 100 meter, you can program the meter to turn off the 'READY' indicator through the SETUp mode.

10. Press the CON key to confirm the calibration. The 'CON' indicator flashes for one second and disappears.
11. Upon confirmation, the instrument is calibrated to the buffer indicated in the secondary display.
12. The secondary display automatically scrolls to the next pH buffer calibration option i.e. pH 10.01.

13. For 1-Point Calibration, this can be ignored and you can exit to the [MEAS] mode by selecting the CAL/MEAS key.

NOTE: The 'Or' indicator flashes if the selected buffer value is not within +/- 0.50 pH from the measured pH value.

14. To calibrate 2 or more points, press the MI/▲ and MR/▼ key to scroll through the various buffer pH options.
15. Select the second pH buffer for calibration accordingly. Repeat steps 4 to 14 above.

16. Once calibration is confirmed at the second point, you can proceed to calibrate at the third point without the need to return to Measurement mode. Just select the desired buffer by using MI/▲ or MR/▼ key.

NOTE: For pH 100 meter you can check on which buffer calibration points were being calibrated using Program 2.2 under SETUP mode (see section 9.2.1 on Electrode Data).

NOTE: To exit from pH calibration mode without confirming calibration, DO NOT press CON in step 11. Press CAL/MEAS instead.

If the selected buffer value is not within ± 1.0 pH from the measured pH value: the electrode and buffer icon blink and the ERR annunciator appears in the lower left corner of the display.

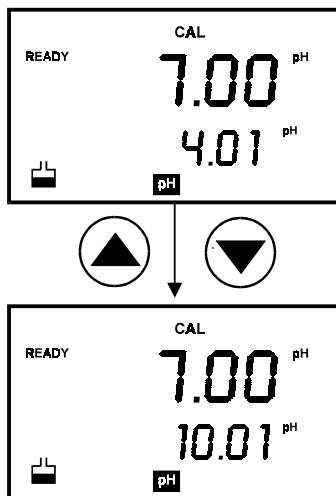

Figure 16: Calibration for second point

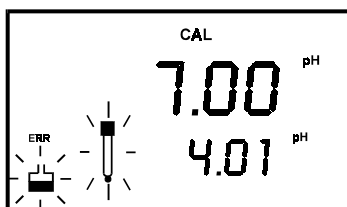

Figure 17: Err message and electrode icon will appear if incorrect buffer are used

4.3 pH Calibration (without ATC)

When the CyberScan meter is not used with a temperature probe, it is necessary to calibrate the temperature first prior to pH calibration.

1. Calibrate for temperature as described in the procedure in Section 4.4.1 - *Temperature Calibration Without ATC Probe*.
2. Next, proceed with the pH calibration as described in the above section.
3. The meter is now calibrated at a fixed temperature.

NOTE: To exit this program without confirming the temperature calibration value, DO NOT press CON. Press CAL/MEAS instead.

4.4 Temperature Calibration

The temperature sensor is factory calibrated. Calibrate the temperature probe only if you suspect the temperature errors that may have occurred over a long period of time or if you have a replacement temperature probe. This procedure offers offset adjustment of probe to ensure more accurate temperature measurement.

In the event where there is no temperature sensor, this procedure can also be performed for Manual Temperature Compensation (MTC).

4.4.1 Temperature Calibration Without ATC Probe

1. Switch the meter on. Press the MODE key to select temperature mode, [Temp].
2. Press the CAL/MEAS key to enter temperature calibration mode. The primary display indicates the pH value, and the secondary display shows the temperature.
3. Press ▲ or ▼ key to select temperature value that matches the temperature reading shown in your reference thermometer.
4. Once you have selected the correct temperature, press CON key to confirm.
5. The CON indicator flashes for one second and disappears.
6. Press CAL/MEAS key to return to the pH measurement mode.

NOTE: To exit this program without confirming the temperature calibration value, DO NOT press CON. Press CAL/MEAS instead.

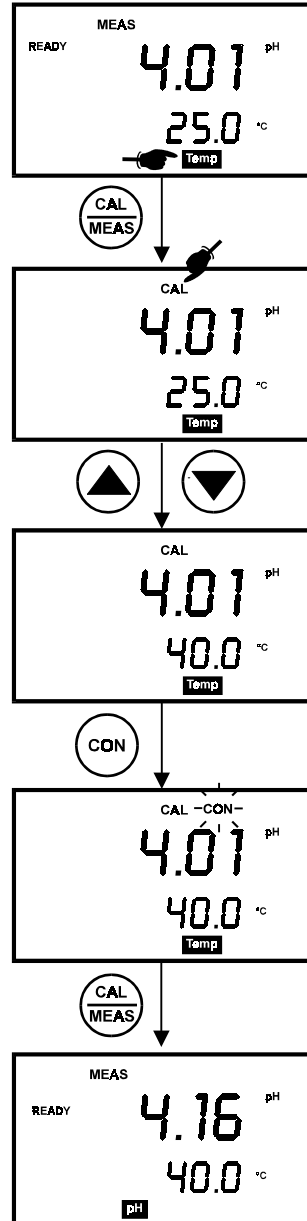

Figure 18: Temperature Calibration

4.4.2 Temperature Calibration With ATC Probe

1. Make sure the ATC probe is attached to the meter. Refer to Figure 7 in Section 3.2.2.
2. Switch the meter on. Note the ATC indicator.
3. Press the MODE key to select temperature mode, [Temp].
4. Dip the ATC probe into a solution of known temperature (i.e. a temperature bath). Allow time for the temperature probe to stabilize.
5. Press the CAL/MEAS key to enter temperature calibration mode. The primary display indicates the pH value, and the secondary display shows the temperature.
6. Press ▲ or ▼ key to select temperature.
7. Once you have selected the correct temperature, press CON key to confirm.
8. The CON indicator flashes for one second and disappears.
9. Press CAL/MEAS key to return to the pH measurement mode.

NOTE: To exit this program without confirming the temperature calibration value, DO NOT press CON. Press CAL/MEAS instead.

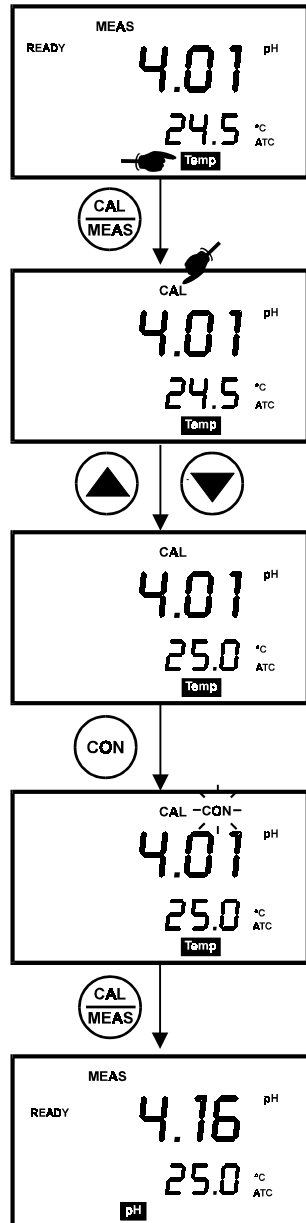

Figure 19: Temperature calibration with temperature probe

4.5 Calibration Procedure for Relative mV Measurements (For pH 100 Only)

Relative millivolt calibration is used in ISE measurements, where it is common to use the lowest concentration mV value as the base value for measurements. All subsequent measurements will then be based on this reference value. For Relative mV calibration, carry out the following procedure:

1. Press the MODE key to enter the Relative mV mode.
2. The primary display shows the absolute mV reading while secondary display shows the temperature.
3. On pressing the CAL key, the calibration mode is activated. The 'CAL' indicator is displayed on the LCD. The rest of the display remains the same.
4. With the MI/▲ and MR/▼ keys, adjust the displayed absolute mV value to the base value required e.g. 350.0 mV (Figure 20).

NOTE: To exit this mode or re-enter the desired value without confirming, DO NOT press CON key. Press the CAL/MEAS key instead.

5. Press CON key to confirm the calibration. The CON indicator flashes for one second and disappears.
6. The LCD now displays 0 mV reading. The meter is now calibrated for Relative mV measurements.
7. On pressing the CAL/MEAS key, the meter returns to the measurement mode. The primary display now indicates the Relative mV readings, bearing in mind that the selected base value is 350.0 mV.

The value displayed is calculated as follows:

Displayed Value = (Absolute mV reading) – (Relative mV Base Value)

NOTE: For pH 100 model, you can check the Relative mV base value in the SETUP program P2.4.

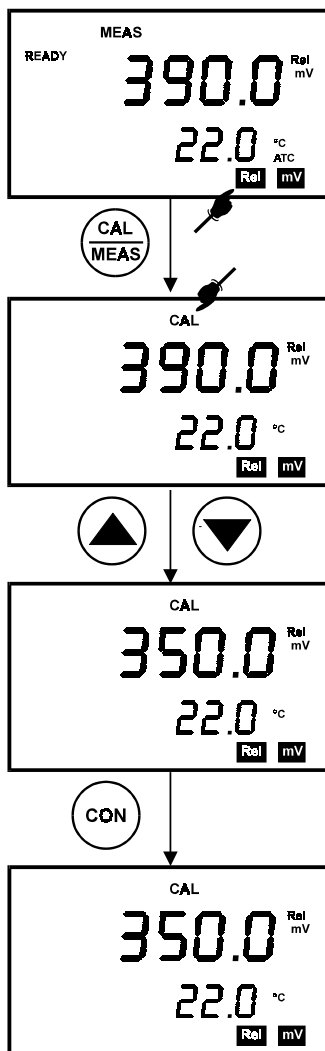

Figure 20: Relative mV calibration (For pH 100 only)

4.6 Erasing Calibrated Values (For pH 100 only)

To erase the calibrated values in the memory follow either one of the following procedures:

1. Enter the SETUP mode. (See section 9.1). Program 1.0 clears all memory in storage, including the calibrated values. You cannot selectively delete data.
2. Or you can recalibrate the instrument. A new calibration value automatically overwrites the existing value in the memory.

5 MEASUREMENT

This meter is capable of taking measurements with automatic or manual temperature compensation. Automatic temperature compensation only occurs when a temperature sensor is plugged into the meter. If there is no temperature sensor plugged into the meter, the default manual temperature setting is automatically 25.0 °C. You can manually set the temperature to match your working conditions using a separate thermometer.

NOTE: Remove the protective rubber cap or soaker bottle of the electrode before proceeding with measurement. Take care not to exert too much force as this may cause damage to the electrode.

5.1 Automatic Temperature Compensation

For automatic temperature compensation (ATC) simply plug the temperature probe into the meter. The ATC indicator will light up on the LCD.

NOTE: If you are using a temperature probe, the probe must be submersed in the liquid you are measuring.

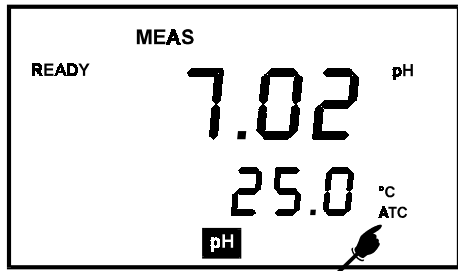

Figure 21: ATC annunciator will light up when connected to temperature probe

5.2 Manual Temperature Compensation

IMPORTANT: For manual compensation, you must disconnect the temperature probe. The [ATC] annunciator will disappear from the LCD.

1. Switch the meter on. Press the MODE key to select [TEMP] mode.
2. Press the CAL/MEAS key to enter Temperature calibration mode. The CAL indicator will appear above the primary display.
3. The primary display shows the current pH reading and the secondary display shows the default temperature value 25 °C.
4. Check the temperature of your sample using an accurate thermometer.
5. Press the ▼ or ▲ keys to set the temperature to the measured value obtained from step 4.
6. Press CON to confirm the selected temperature. The [CON] indicator will flash momentarily.
7. Press the CAL/MEAS key to exit and return to pH measurement mode.

The meter will now compensate pH readings for the manually set temperature.

NOTE: To exit this program without confirming the manual temperature compensation value, DO NOT press CON in step 6. Press CAL/MEAS instead.

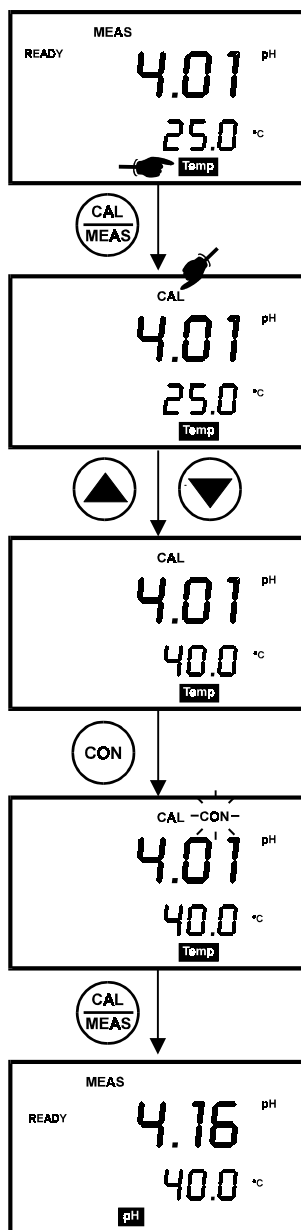

Figure 22: pH measurement using Manual Temperature Compensation

5.3 Taking Measurements

Be sure to remove the electrode soaker bottle or protective rubber cap on the electrode before measurement.

To take readings:

1. Rinse the probe with de-ionized or distilled water before use to remove any impurities adhering to the probe body. If the pH electrode has dehydrated, soak it for 30 minutes in Eutech Instruments electrode storage solution or 2M – 4M KCl solution (sold separately).
2. Press ON to switch on meter. The MEAS annunciator appears on the top center of the LCD. The ATC indicator appears in the lower right-hand corner to indicator Automatic Temperature Compensation (section 5.2 on Manual Temperature Compensation).
3. Dip the probe into the sample.
4. When dipping the probe into the sample, the sensor or the glass bulb of the electrode must be completely immersed into the sample. Stir the probe gently in the sample to create a homogeneous sample.
5. Allow time for the reading to stabilize. Note the reading on the display.
6. To toggle between pH and mV (or Rel mV) readings, press the MODE key.

The READY mode informs you that the readings are stable within a range of ± 0.01 pH. When this occurs, the mode annunciator READY appears on the top left corner of the display. The reading is held until the measured value exceeds the specified range when the READY display is turned off.

NOTE FOR pH 100 ONLY:

- The READY mode is turned on by default i.e. when the SETUP (READY) mode is not programmed. You can verify this by going through SETUP mode (See section 9.3.2). If READY mode is switched off, the annunciator will not be displayed.
- For ATC measurements, attach the probe to the CyberScan. The ATC mode annunciator lights up. Insert the probe into the solution to be measured so that the sample temperature can be recorded and compensated for.

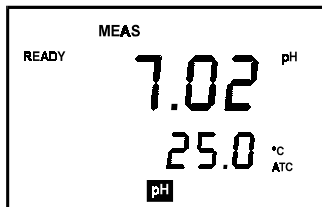

Figure 23: Measurement mode

6 HOLD FUNCTION

This feature allows you to hold the value of the measurement reading until it is more convenient to note the reading. This mode can be invoked at any time when you are in the MEAS mode. You may also store the held value into memory using MI/▲ key (*available only in pH 100 meter*).

1. In the measurement mode (either pH, mV or Rel mV, press the HOLD key.
2. "HOLD" indicator will appear on the display.
3. To release the held value, press HOLD again. You can continue to take measurements.

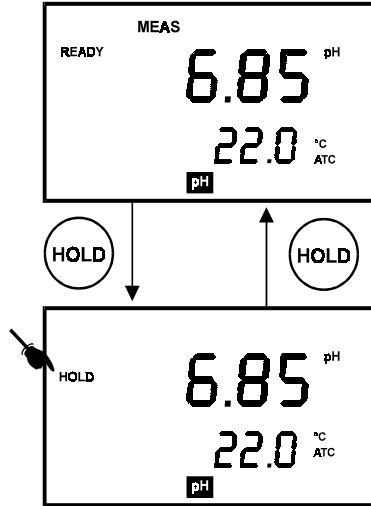

Figure 24: HOLD function

NOTE:

- The meter shuts off automatically after 20 minutes after last key is pressed. If the meter is shut off either automatically or manually, the HOLD value will be lost.
- In the pH 100 model, the SETUP function allows you to turn off the auto shut-off feature.

7 MEMORY FUNCTION (FOR pH 100 ONLY)

The memory function is available only in the CyberScan pH 100 meter. This meter stores data in sets:

- pH and temperature
- mV and temperature
- Relative mV and temperature

The pH 100 meter can store up to 16 sets of data in any combination of values. For example, you can store 7 pH and 9 mV values.

This meter uses the Last-In-First-Out (LIFO) method of memory management. If the memory is already full, the first value that was stored in the memory will be erased to create space for the new value to be input.

7.1 Memory Input

To store a reading:

1. During any measurement function [MEAS], press MI key to input any data into the memory.
2. The [MEM] annunciator will flash momentarily (Figure 25).
3. The meter then returns to measurement mode.
4. You can switch to the next measurement mode (by pressing the MODE key), and press MI key to input data into memory.

NOTE: If the memory is full, the first value stored will be erased to create space for the new value.

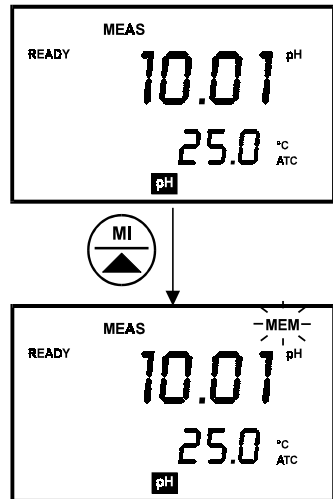

Figure 25: Memory In function

7.2 Memory Recall

This function recalls the previous readings stored in the memory. You can only access MR from the measurement mode.

Make sure you are in the correct measurement mode to retrieve previously stored data. For example, if you want to retrieve data stored during pH measurement mode, you will need to be in pH measurement mode to retrieve the data.

To recall readings:

1. Switch the meter ON, and press MODE key for the appropriate measurement parameter.
2. Press the MR key once to retrieve the last reading stored.
3. The memory annunciator, [MEM], will appear on the display (See Figure 26).
4. Note the reading.
5. If necessary, press MR key again to retrieve the next memory.
6. To retrieve data from another measurement mode (for example, mV), press MODE key until you arrive at pH measurement mode.
7. Press the MR key once to retrieve the last reading stored in pH. Note the reading.

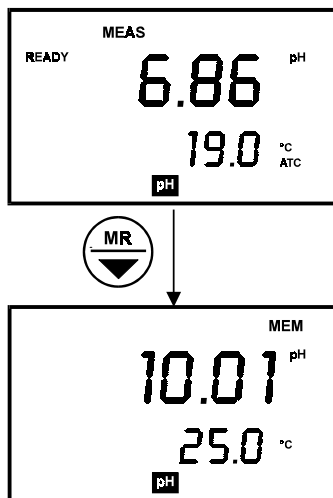

Figure 26: Memory Recall function

8. If necessary, press MR key again to retrieve the next memory.
9. Once all readings are recorded, press CAL/MEAS key to exit memory recall mode and return to measurement mode.

NOTE: Memory data is retained even if the power of the unit is switched off. The memory will be completely erased according to the following situation:

- a. When the batteries are removed (all functions, including memory, are reset);
- b. Memory can be cleared through SETUP function under program P1.0.
- c. When meter is reset through SETUP function under program P1.1.

8 PRINT FUNCTION (FOR pH 100 ONLY)

The CyberScan pH 100 is equipped with a PRINT key that facilitates the printing of data from a printer or storage of data into the computer in the form of a data file.

8.1 Using the CyberScan pH 100 With The Printer

1. To use the CyberScan pH 100 directly with a printer, the printer should have either a 9 pin or a 25 pin RS 232C serial port.
2. Printer dip switches should match with the CyberScan meter communication setup. The printer should have options to receive 8 data bits, even (2), odd (1) or none (0) parity bit and one (1) or two (2) stop bits. These parameters are standard printer options. Please refer to your printer's instruction manual for more information on its communication setup protocol.
3. Use the cable provided to connect the meter to the printer. If the printer has a 25 pin connector, use a 9 to 25 pin converter (available separately) or make your own cable taking note of the connection parameters as described in Section 3.4.1 on page 9.
4. Set the dip switches of the printer to accept serial data. This would be required if the printer has both serial and parallel interfaces. Set the dip switches to accept 8 data bits (Normally, printers would have a selection for 7 or 8 data bits).
5. Turn on the meter.
6. Set the printer dip switches or change the CyberScan pH 100 setup parameters for the proper baud rate, parity and stop bits. Refer to Section 9.4 for more detail.
7. Ensure that these parameters are identically set on both the printer and the meter.
8. Insert the paper and switch the printer on.
9. To send data to the printer, press the PRINT key.

Printing Errors

Problem	Probable Cause
Prints Garbage	Baud rate/parity/data bits mismatch
Nothing is printed	Cable not properly connected or improper printer dip switch setting.

The CyberScan meter displays error by blinking the printer and error annunciators alternately if the printer is not ready to receive data or if the printer is off. See Figure 14 on Page 10. As soon as the printer is ready, the error display will automatically go off. While the meter is displaying the printer error, you may press the 'CAL/MEAS' key to go back to the measurement mode.

8.2 Sending Data To Computer

To send data to the computer, connect the RS232C cable from the base of the CyberScan pH 100 to the communication port of the computer. Load and run the CYDATA data acquisition program ensuring that the parameters of the settings in the CyberScan pH 100 and the CYDATA are identical (See Section 10.4 "Setting Up CYDATA" on page 37). To print, press the PRINT key.

8.2.1 Printing Measurement Data

To print any data that currently being measured, press the PRINT key as shown in the diagram below. Note that the PRINT capability is available for the [MEAS], [Rel mV] and [mV] modes. The data will be printed onto the printer paper or the screen of the CYDATA program automatically.

8.2.2 Printing Data From Memory

The CyberScan pH 100 meter can print data that is stored in the memory. Firstly ensure that the cables are properly connected to either the printer or the computer and the units are configured to receive data from the meter.

Change the mode to the mode of measurement from which data needs to be printed. For example, the data stored is in the memory location of the mV mode.

Scroll to the data that needs to be printed by pressing the MR/▼ key. To print, press the [PRINT] key.

The data displayed will then be sent to the printer or the computer.

Parameter	Format
pH, Rel mV, mV	-
Temperature	-
Date	mm/dd/yy
Time	hh/mm/ss

Note:

Abbreviation	
mm	month
dd	date
yy	year
hh	hour
mm	minute

The data will be printed in the following format:

pH : 5.41	Temp: 25.0	Date: 12-21-1996	Time: 09:52:39
pH : 5.43	Temp: 25.0	Date: 12-21-1996	Time: 09:52:42
pH : 5.74	Temp: 25.0	Date: 12-21-1996	Time: 09:53:57
pH : 6.03	Temp: 25.0	Date: 12-21-1996	Time: 09:54:00
R.mv: 1.4	Temp: 25.0	Date: 12-21-1996	Time: 09:57:00
R.mv: -1.1	Temp: 25.0	Date: 12-21-1996	Time: 09:57:03
R.mv: -3.2	Temp: 25.0	Date: 12-21-1996	Time: 09:57:07
R.mv: -4.9	Temp: 25.0	Date: 12-21-1996	Time: 09:57:10
mv : -6.9	Temp: 25.0	Date: 12-21-1996	Time: 09:57:15
mv : -8.2	Temp: 25.0	Date: 12-21-1996	Time: 09:57:18
mv : -10.3	Temp: 25.0	Date: 12-21-1996	Time: 09:57:22
mv : -11..2	Temp: 25.0	Date: 12-21-1996	Time: 09:57:24
mv : -12.9	Temp: 25.0	Date: 12-21-1996	Time: 09:57:28
mv : -14.1	Temp: 25.0	Date: 12-21-1996	Time: 09:57:31
mv : -15.9	Temp: 25.0	Date: 12-21-1996	Time: 09:57:37
mv : -17.4	Temp: 25.0	Date: 12-21-1996	Time: 09:57:40
mv : -17.8	Temp: 25.0	Date: 12-21-1996	Time: 09:57:43
mv : -18.6	Temp: 25.0	Date: 12-21-1996	Time: 09:57:46
mv : -19.7	Temp: 25.0	Date: 12-21-1996	Time: 09:57:49
mv : -22.5	Temp: 25.0	Date: 12-21-1996	Time: 09:57:52
mv : -20.9	Temp: 25.0	Date: 12-21-1996	Time: 09:57:55
mv : -33.0	Temp: 25.0	Date: 12-21-1996	Time: 09:57:58
pH : 5.69	Temp: 25.0	Date: 12-21-1996	Time: 10:11:35
pH : 5.45	Temp: 25.0	Date: 12-21-1996	Time: 10:11:38

9 ADVANCED SETUP FUNCTIONS (FOR pH 100 ONLY)

The advanced setup mode lets you customized your meter's preferences and defaults. The Eutech Instruments' standard CyberScan meter features four different programs that organize all setup parameters. Each has been divided into several options. The programs and options are elaborated under the following sections:

Program	Description	Sub-Group Functions	Section
P 1.0	Software Initialization	Memory Clear and Reset Options	9.1
P 2.0	View Electrode Data	pH slope & offset, calibration data, & relative mV offset	9.2
P 3.0	Meter Configuration	Set pH resolution, READY setting, & auto-off function	9.3
P 4.0	Communication Data Setting	Set baud rate, parity & stop bit.	9.4

To enter the SETUP mode, press the SET key from either the pH, Relative mV or mV measurement [MEAS] mode. The meter automatically enters Program 1, Option 0 (P1.0). NOTE: Entry to SETUP is only accessible from the [MEAS] mode.

Selection of the CON key confirms selection of the options chosen. The instrument then automatically scrolls to the next program. Within each program, the user can use MI/▲ or MR/▼ keys to make appropriate selections. There are some options that only permit the viewing of data and are useful for diagnostic purposes.

Ensure that the CON key is pressed to confirm your option in each program. Should you desire to exit from the program after the confirmation of your choice or abort the [SETUP] mode, press the CAL/MEAS key to return to the [MEAS] mode.

Addendum 1 shows the overall program setup and the factory default settings.

9.1 Program 1 – Software Initialization

This program deals with the initialization of the memory and calibration data. "OFF" is the default setting for both Memory Clear and Reset. Accidental selection of wrong option will wipe out the memory.

9.1.1 P1.0 : Memory Clear

Activation of this option by selecting 'ON' clears all stored measurement values in the memory (5 sets of values each for pH, mV and Rel. mV with temperature). Under default condition this option is not activated (set to OFF).

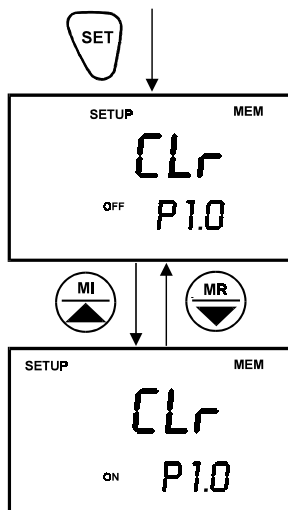

Figure 27: P1.0, Memory Clear

9.1.2 P1.1 : Reset

Activation of this option by selecting 'ON', resets the instrument. The instrument immediately switches off. You need to power 'ON' the instrument before proceeding with any other functions.

RESET clears all data in memory (5 sets of values each for pH; mV and Rel. mV with temperature), calibration data and setup data. All settings return to factory defaults. The RESET is OFF by default.

This feature is useful when the meter is used by someone who needs to recalibrate to a different electrode and select his own SETUP options.

Press CON key to continue to next program. NOTE: Data cannot be selectively deleted.

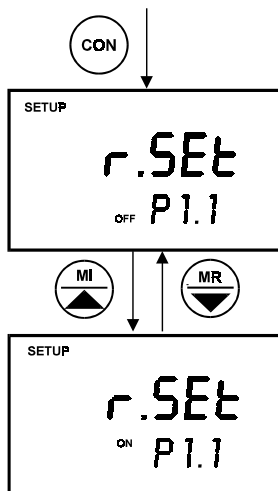

Figure 28: Reset Meter

9.2 Program 2 – Electrode Data

This program allows you to check on electrode parameters for diagnostic purposes.

9.2.1 P2.0 : Electrode Offset

The primary display shows the pH electrode offset value in mV. The offset is calculated based on the buffer 7.00 calibration. If no calibrations have been performed, the primary display shows -0.00 mV.

9.2.2 P2.1 : Electrode Slope

The primary display indicates the electrode slope in percentage. The slope displayed is the average slope based on the calibrations performed. If the meter has not been calibrated, or under default conditions the primary display reads 100.00.

9.2.3 P2.2: Calibration pH buffer data

Records all the pH buffer calibrations made on the meter. This option allows you to view all 5 calibration points. Use MI/▲ or MR/▼ key to scroll through the five calibration points. See Figure 29.

If there has been no calibration performed at any particular buffer option, the display will indicate “- - - -”. See Figure 30.

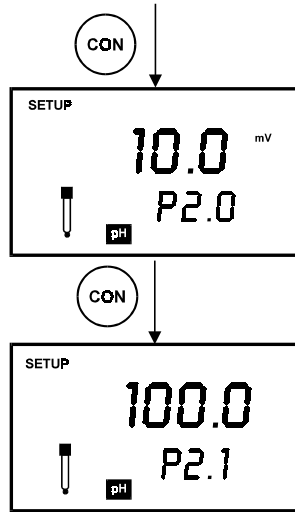

Figure 29: Electrode diagnostics, offset & slope

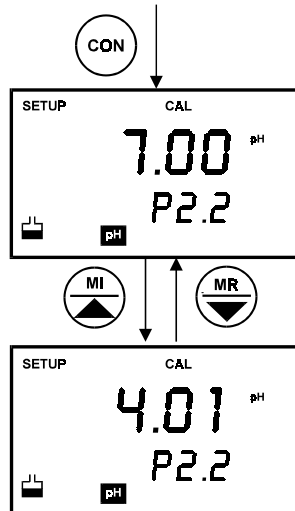

Figure 29: View calibration points

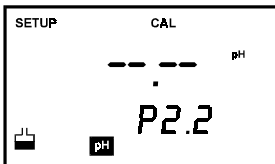

Figure 30: No calibration performed

9.2.4 P2.3: Calibration Temperature

Indicates the temperature of the last calibration performed. This is a View Only mode.

Default setting is 25 degrees C.

See Figure 31.

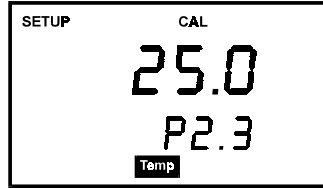

Figure 31: Temperature of the last calibration performed

9.2.5 P2.4: Relative mV offset value

The primary display indicates the Relative mV base value in mV. This base value is based on your pre-selected value during calibration for REL mV measurement. If REL mV has not been calibrated or under default conditions, the primary display reads 0 mV.

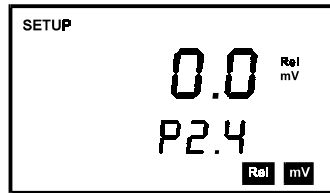

Figure 32: Relative mV base value

9.3 Program 3 –Meter Configuration

The following three options are available to the user for customization:

9.3.1 P3.0 : Resolution

The resolution of the instrument in the pH measurement mode can be user selected to 0.1 or 0.01 pH. Under default condition, the instrument is set for 0.01 pH resolution.

LCD Value	Description
0.01	A resolution of 0.01 pH is shown.
0.1	A resolution of 0.1 pH is shown.

1. Use MI/▲ or MR/▼ keys to select the resolution desired. See Figure 33.

2. Press CON key to continue to P3.1.

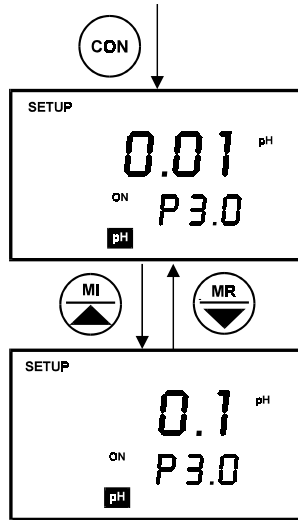

Figure 33: Setting pH resolution

9.3.2 P3.1 : Ready selection

Activation of the READY option ensures that the READY indicator is displayed when the electrode reading has stabilized.

The stabilization tolerances for the various measurement ranges are as indicated below. Under default conditions, i.e. when the [SETUP] mode is not programmed, the instrument has this option activated.

MODE	VARIATION	RANGE
pH	± 0.01 pH	
mV	± 0.8 pH	< 400 mV
mV	± 1.2 mV	> 400 mV
ON	READY Indicator will appear when the reading stabilizes within ± 0.01 pH	
OFF	READY indicator will not appear.	

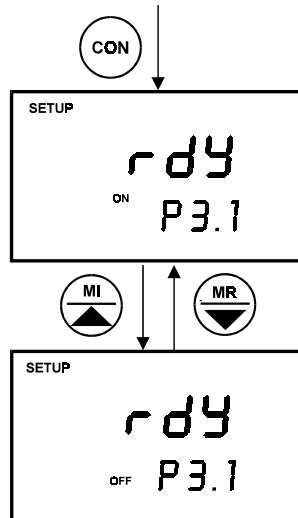

Figure 34: READY Selection

9.3.3 P3.2 : Auto-Off

Activation of the AUTO-OFF option automatically powers off the instrument 20 minutes after the last key selection. This feature is useful for conserving battery power. Under default condition, the instrument has this option activated.

- ON - Meter will automatically switch off 20 minutes after the last key operation.
- OFF - Auto Off mode is switched off.

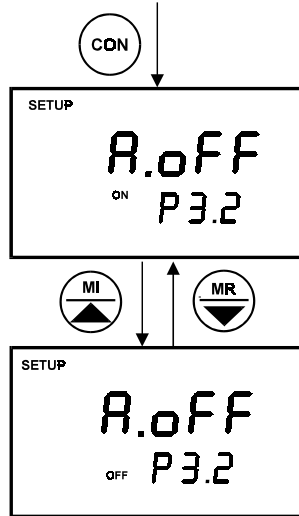

Figure 35: Select Auto-off feature

9.4 Program 4 – Communication Setup

This program allows you to set up the instrument's communication parameters of the CyberScan 100 to enable proper communication with the printer or computer of choice.

9.4.1 P4.0: Baud Rate

You can select a baud rate either at 2.4, 4.8, 9.6 or 19.2 Kbps. Under default conditions, the baud rate is set to 9.6 Kbps.

1. From pH or mV measurement mode, press SETUP key.
2. Press CON key (10 times) until P4.0.
3. Use MI/▲ or MR/▼ key to change different baud rate.
4. Press CON key to confirm and continue to set Parity in P4.1.

See Figure 36.

NOTE:

To exit without confirming baud rate value, press CAL/MEAS key. This will bring you back to the measurement mode.

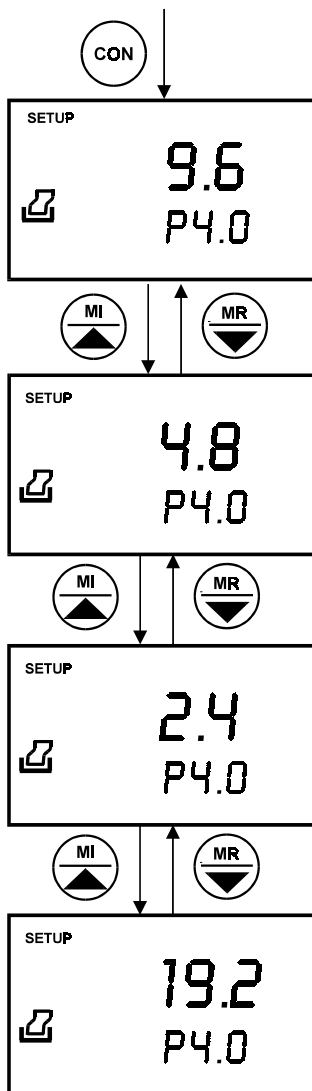

Figure 36: P4.0 Setting Baud Rate

9.4.2 P4.1 : Parity

Parity check allows the unit to monitor the integrity of the data that it transmits. To accommodate for the variances in standards used, three different parity checks have been provided in the table below. The default parity is even (2).

Value	Parity
0	No Parity
1	Odd Parity
2	Even Parity (Default)

9.4.3 P4.2 : Stop Bit

The Stop Bit allows the selection of the appropriate stop bit when transmitting to other peripheral devices (such as printers). You can select the Stop Bit to be 1 or 2 depending upon the model and make of peripheral device (The instruction manual of peripheral device should indicate the stop bit used). Under default conditions the stop bit is 1 (one).

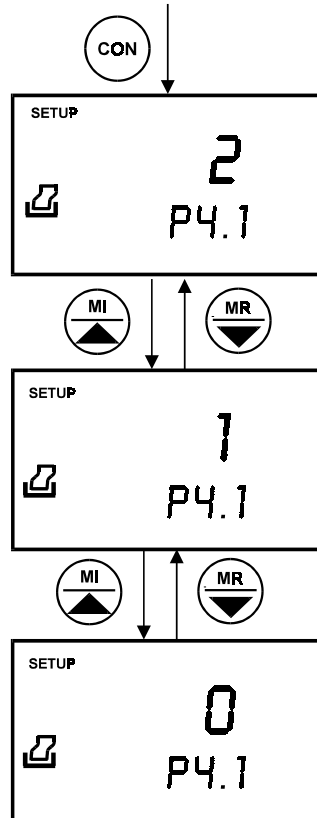

Figure 37: P4.1 Setting Parity Value

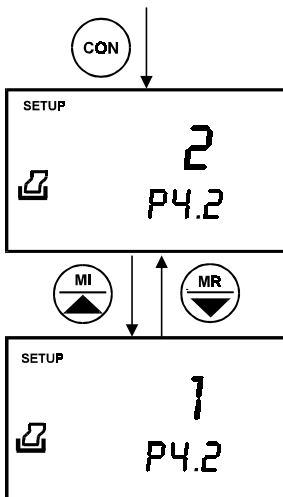

Figure 38: P4.2 Setting Stop Bit value

10 CYBERCOMM PORTABLE - DATA ACQUISITION SOFTWARE (DAS FOR pH 100 ONLY)

The CyberComm Portable software is designed for Eutech's CyberScan pH 100 and CON 200 meters to allow you a convenient means of capturing data for future analysis using other software program such as LOTUS 123, EXCEL or DBASE in Windows®. Often one finds it cumbersome to record and transfer data from one media to another before the required processing can be done. With the CyberComm Portable, this redundant processing can be eliminated or reduced.

10.1 System Requirements

To run the CyberComm Portable program, the following is required:

1. PC - IBM Compatible XT and above with CD-ROM Drive
2. EGA Monitor and above
3. Windows® Operating System '95 and above
4. Connecting communication RS232C cable

10.2 Loading CyberComm Portable

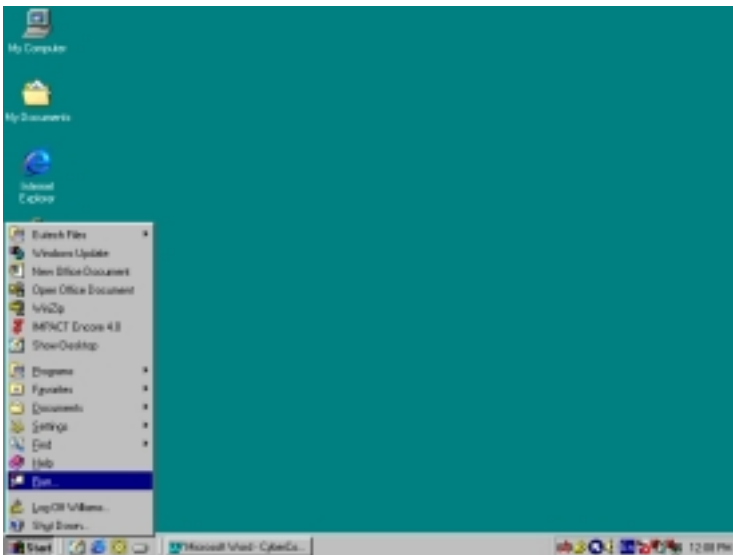

Figure 39 - Insert Eutech Instruments' CD-ROM containing Data Acquisition Software (DAS) into your CD-ROM drive and click on START button and RUN command.

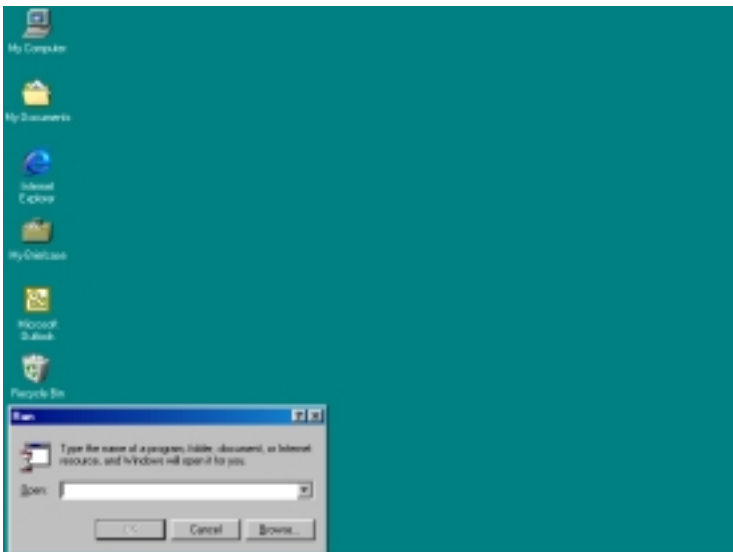

Figure 40 - Click on 'Browse' button and locate CD-ROM drive

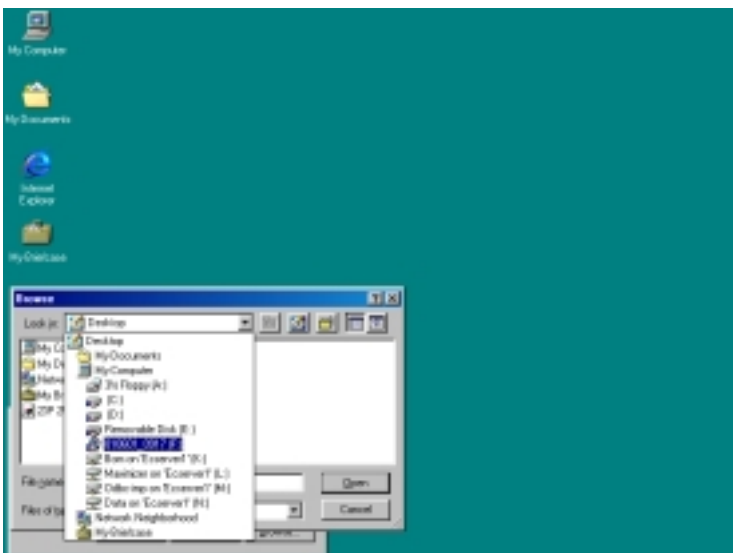

Figure 41 - Locate the CyberComm Portable Setup program in the CD-ROM under "CyberComm Portable" sub-directory.

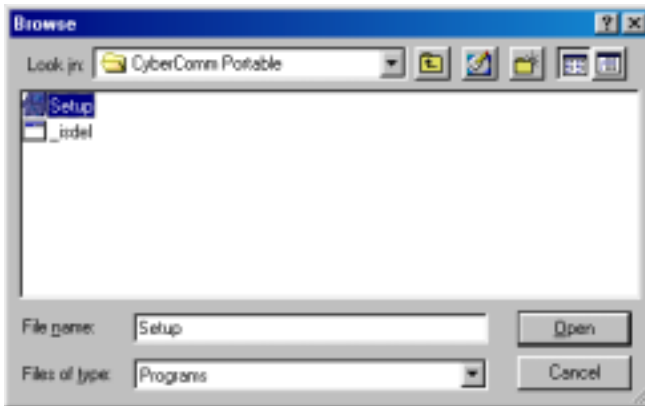

Figure 42 - Select "Setup" program and click the OPEN button.

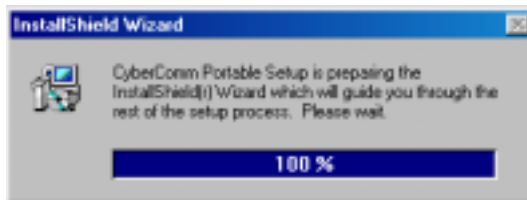

Figure 43 - InstallShield Wizard dialog box appears.

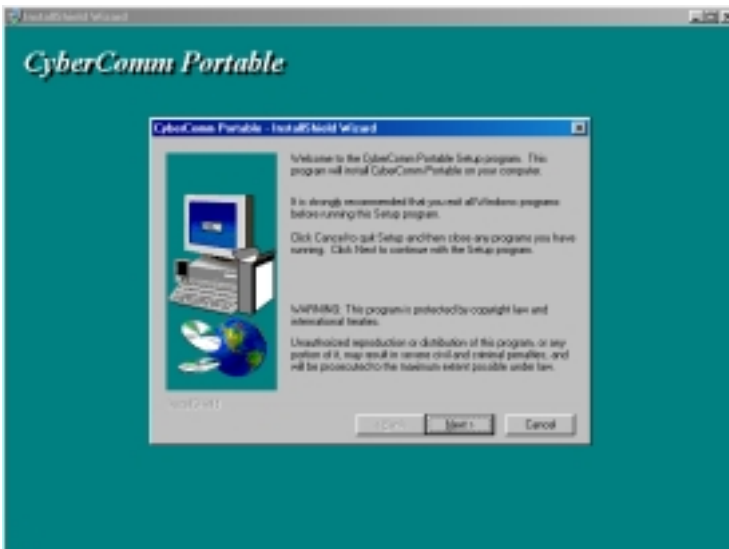

Figure 44 - Click on Next button.

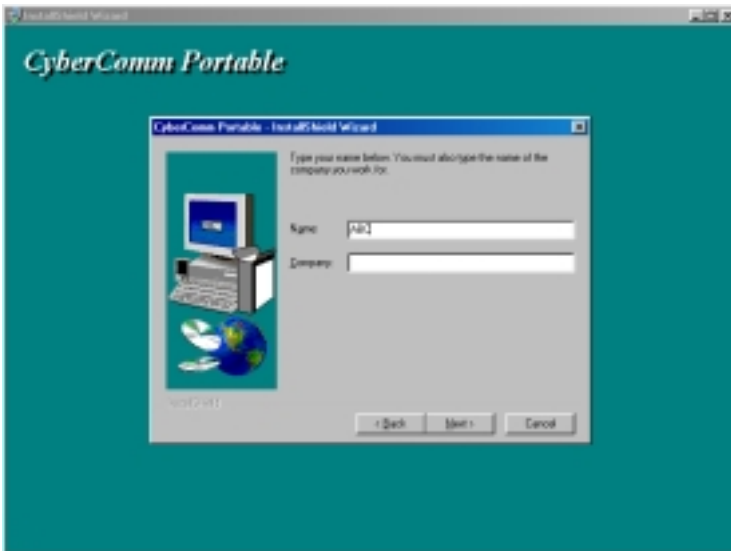

Figure 45 - Key in your name and company name and click NEXT button.

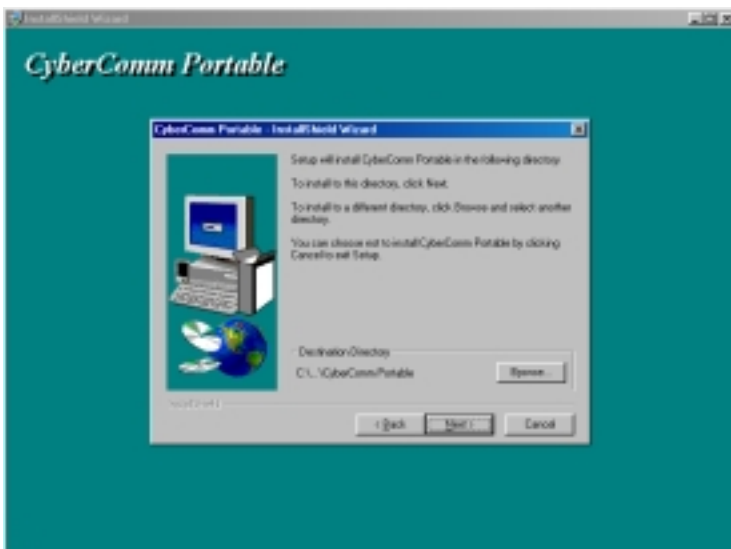

Figure 46 - To select another Destination Directory to install the program, click on BROWSE button. Otherwise, click NEXT button.

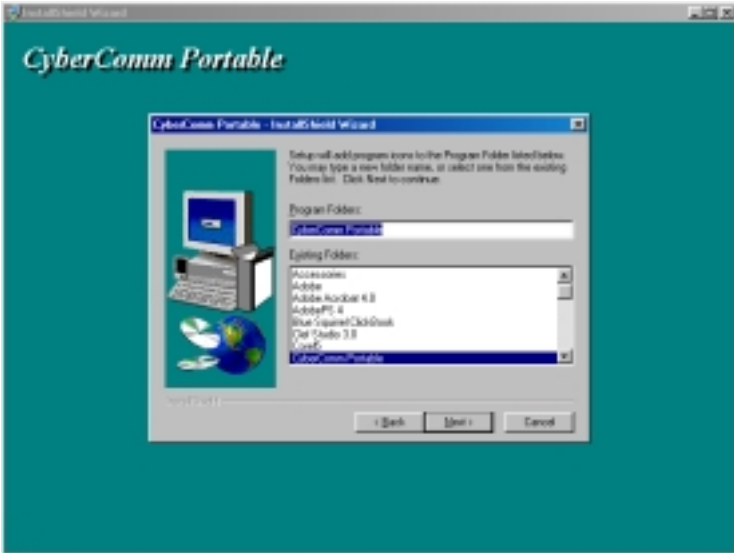

Figure 47 - Creating a new program folder. Click on NEXT button.

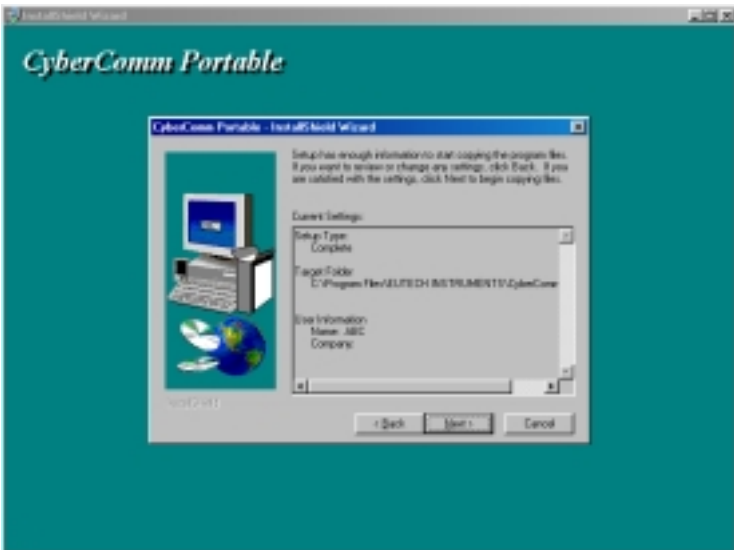

Figure 48 - Click on NEXT button.

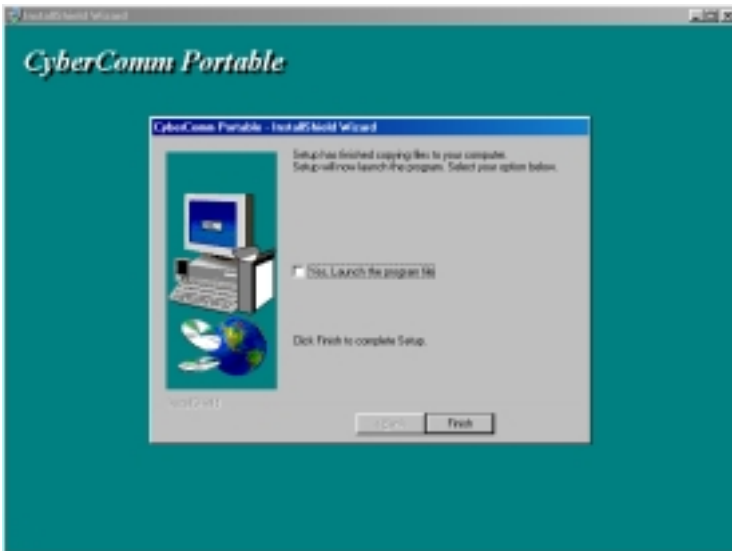

Figure 49 - The CyberComm Portable DAS program is fully installed. Click on FINISH button to end installation.

10.3 Running CyberComm Portable

Before running the CyberComm Portable program, please ensure that the RS232 cable is connected between the computer's serial port and the meter's port.

A 1-meter RS232 cable, 9-pin male to 9-pin female connector (order no. EC-CA01M09F09) is supplied with the CyberScan pH 100 meter.

For additional information on the connection, please refer to section 3.4 "Connecting the RS232C Cable (Only For CyberScan pH 100)".

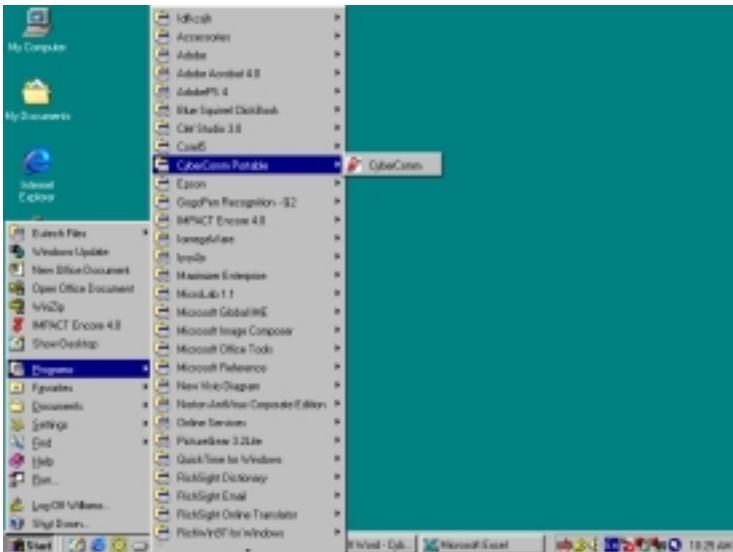

Figure 50 - Run the CyberComm Software program

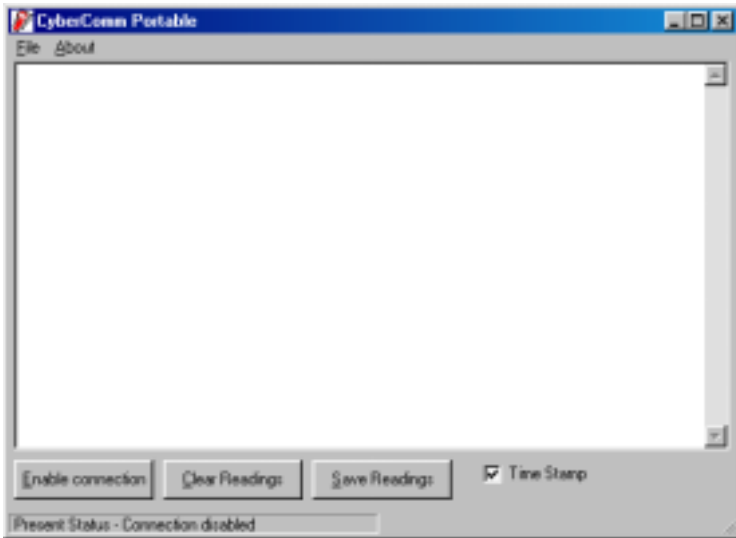

Figure 51 - The opening screen will appear as above.

BUTTONS & CHECK-BOX

- **Enable Connection** - Click this button to enable communication between meter and computer.
- **Clear Readings** - To clear all data and start all over again.
- **Save Readings** - To save all data displayed in either *.dat or *.txt format.
- **Time Stamp** - To include Time and Date stamp when collecting the data. Time and date information comes from the computer.

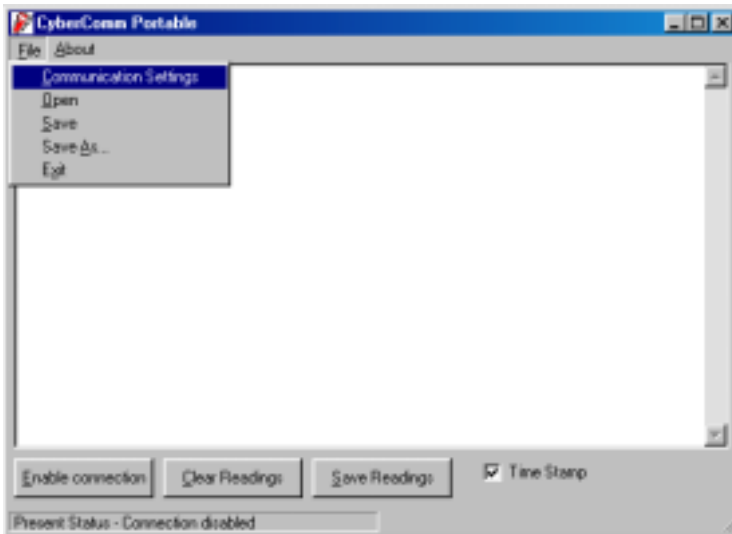

Figure 52 - Under File Menu setting, you can change various parameters. Under ABOUT menu, details of Eutech Instruments' contact information, email address and updates are shown.

MENU

- **Communication Settings** - To set communication port number, baud rate speed, parity and stop bits protocol.
- **Open** - To open previously saved data file.
- **Save** - To save current data captured.
- **Save As** - To save current data set in another format such as *.dat or *.txt.
- **Exit** - To exit from CyberComm Data Acquisition Software program.

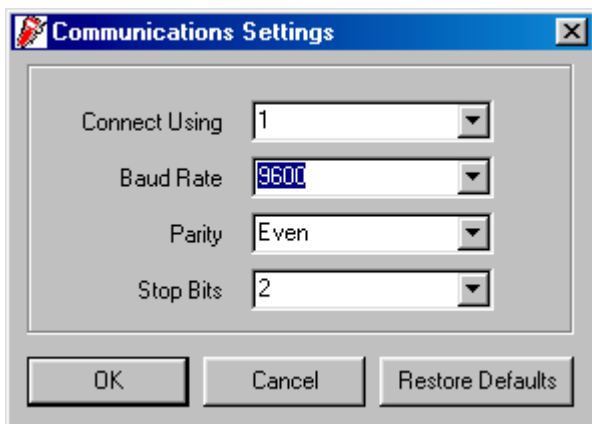

Figure 53 - Communication Settings for computer's Com port. It must **match** with COM port settings on CyberScan pH 100 meter. Please refer to Section 3.4.1 "RS232C Configuration" for the settings.

COMMUNICATION SETTINGS

- **Connecting Use** - To select communication port, 1 or 2.
- **Baud Rate** - To select different baud rate, 2400, 4800, 9600 or 19200 bps (bits per second).
- **Parity** - To select different parity, Even, Odd or None.
- **Stop Bits** - To select different stop bits, 1 or 2.

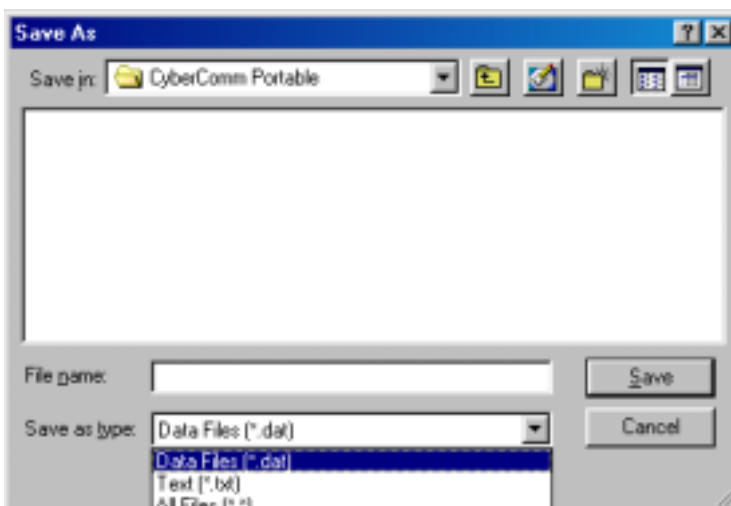

Figure 54 - Under SAVE AS menu, you can save your data as *.dat or *.txt formats

10.4 Capturing And Printing Data Into Computer Using CyberComm Portable

After matching the Communication Settings between your computer using CyberComm Portable and the CyberScan pH 100 meter, you can now capture data into your computer for analysis and storage purposes.

1. Ensure the 1-meter RS232 communication cable (supplied with the meter) is connected between the computer and the CyberScan pH 100 meter's Com port. Refer to section 3.4 "Connecting the RS232C Cable (Only For CyberScan pH 100)" for connection procedure.
2. Switch on the CyberScan pH 100 meter and run the CyberComm Portable DAS software as indicated in Figures 50 and 51.
3. Click "ENABLE CONNECTION" button.
4. With the CyberScan pH 100 meter switched on, press the PRINT key to send data to the computer. See Figure 55 below.
5. You can use MODE key on the meter and change to other parameter such as mV or Rel mV and print data accordingly.
6. You can also check off the Time Stamp function, so as to print without the Time and Date information.
7. You can click Clear Readings button to begin another set of measurements, or click Save Readings to store readings for future retrieval.

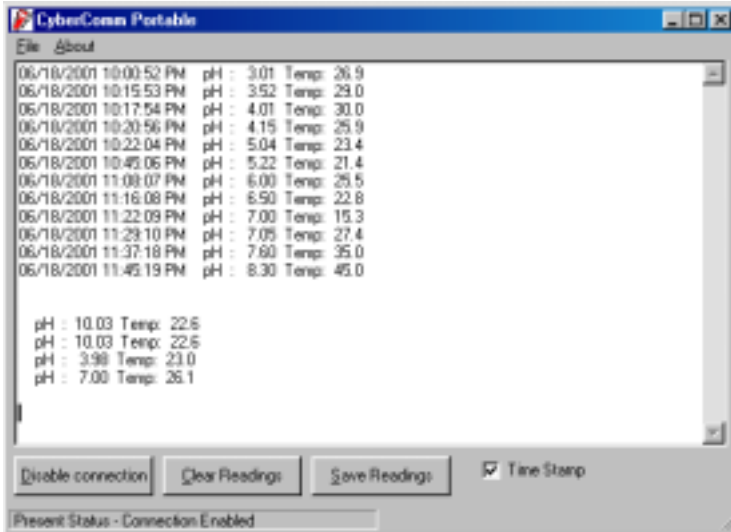

Figure 55 - A set of data print in CyberComm Portable DAS

10.5 Trouble-shooting Guide

a) Problem: Unable to PRINT

When press PRINT key on CyberScan pH 100 meter, the "Print" and "Err" annunciators blink on the meter's LCD screen as shown in Figure 56.

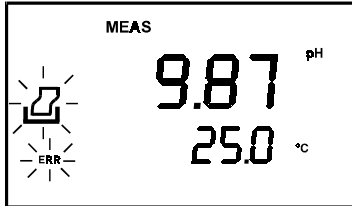

Figure 56 - "Print" and "Err" icons blinking

POSSIBLE CAUSES	SOLUTIONS
You have not "ENABLE CONNECTION" in the CyberComm Portable DAS program.	Click on "ENABLE CONNECTION" in the CyberComm Portable DAS program.
The "Communication Settings" in the CyberComm Portable DAS program is different from meter's setup.	Match the COM port number, baud rate, parity and stop bits information between the CyberComm Portable DAS program and the meter.
The COM port number in the CyberComm Portable DAS program is wrong.	Change the COM port number (1 or 2) in the CyberComm Portable DAS program.
Your computer's COM port setting may be wrong.	Check your computer's hardware settings (through Windows OS, BIOS, or any other OS) and refer to computer's manual or consult with the computer's manufacturer.
You may have used the wrong communication cable.	Make sure you use the RS232C cable supplied together with the meter (Part No. EC-CA01M09F09). Check the RS232C configuration as described in the meter's instruction manual.

b) Problem: Unusual characters appear in data

When press PRINT key on CyberScan pH 100 meter, additional characters such as the following appear.

06/18/2001 1:48:38 PM? R.mv? -900? Temp: ?22.6

POSSIBLE CAUSES	SOLUTIONS
The Baud rate, parity or stop bit information are not matched.	Check the communication setup for both CyberComm Portable DAS program and meter and ensure both are the same.

To report any bugs, please e-mail to techsupport@eutechinst.com

11 ELECTRODE CARE

11.1 Electrode Maintenance

pH electrodes are susceptible to dirt and contamination and need to be cleaned regularly depending on the extent and condition of use.

11.1.1 Storage

The best results, always keep the pH bulb wet, preferably in pH 4 buffer with 1/100 part of saturated KCl. Other pH buffers or tap water are also acceptable storage media, but avoid storage in de-ionized water. The protective rubber cap filled with the buffer solution provides ideal storage for long periods.

11.1.2 After Use

After measurement is complete, follow the sequence elaborated below for storage.

1. Wash the electrode and reference junction in deionized water.
2. Close the refilling hole by returning its rubber sleeve or stopper cap (Necessary for only refillable electrodes).
3. Store the electrode as mentioned above (Storage section 11.1.1).

11.1.3 Electrolyte Replacement (for refillable electrodes only)

The reference electrolyte needs to be refilled when the electrode has been used for an extended period, or when the internal electrolyte has dried up. To accomplish this, follow the procedure detailed below.

a) Remove the protective rubber cap or sleeve

Remove the protective rubber sleeve to expose the filling port of the electrode. Remove the old reference electrolyte with a syringe and a flexible tube.

b) Fill the new reference electrolyte

Add in fresh electrolyte until it reaches the level of refilling port. The reference electrolyte used should be 4M KCl. Replace the rubber sleeve.

c) Re-use the electrode

Rinse the liquid junction with deionized water and tap dry.

NOTE: If these steps fail to restore normal electrode response, you may attempt to rejuvenate it. (See section 11.4 on Rejuvenation Procedure).

11.2 Electrode Cleaning

Electrodes that are mechanically intact can be restored to normal performance by one or combination of the following procedures.

a) Salt deposits:

Dissolve the deposit by immersing the electrode in tap water for ten to fifteen minutes. Then thoroughly rinse with deionized water.

b) Oil / Grease Films:

Wash electrode pH bulb in a little detergent and water. Rinse electrode tip with deionized water.

c) Clogged Reference Junction:

Heat a dilute KCl solution to 60-80 °C. Place the sensing portion of the pH electrode into the heated KCl solution for approximately 10 minutes. Allow the electrode to cool while immersed in some unheated KCl solution.

d) Protein Deposits:

Prepare a 1% pepsin solution in 0.1M HCl. Allow the electrode to stand in this solution for five to ten minutes. Rinse the electrode with deionized water.

11.3 Electrode Activation

Generally, if the procedure of storage and maintenance had been closely followed, the electrode can be used immediately. However, should the electrode response become sluggish, it may be possible that the bulb has dehydrated. The bulb can be re-hydrated by immersing the electrode in an ideal storage solution (e.g. buffer pH 4 solution) for 1- 2 hours. If this fails, the electrode may require re-activation.

At no time should one touch or rub the glass bulb as this causes the build-up of electrostatic charge.

If the above procedure does not re-activate the electrode to acceptable status, try rejuvenating the electrode by following the procedure outlined below.

11.4 Rejuvenation Procedure

- a) Dip and stir the electrode in freon or alcohol for 5 minutes.
- b) Leave the electrode in tap water for 15 minutes.
- c) Dip and stir the electrode in concentrated acid (e.g. HCl, H₂SO₄) for 5 minutes.
- d) Repeat Step b.
- e) Dip and stir in strong base (NaOH) for 5 minutes.
- f) Leave for 15 minutes in tap water.

g) Test with standard calibration buffer solutions.

CAUTION: Proper eyewear and gloves must be worn when preparing these chemicals and performing this operation.

Finally, test with standard calibration buffer solutions to see if the electrode yields acceptable results. You may repeat steps 'c' to 'f' again for better response (maximum 3 times). If the response does not improve, then the electrode has completed its useful life. Replace with a new electrode.

12 ERROR MESSAGES

The following table provides a guideline to enable diagnosis of possible problems indicated by the messages generated by the CyberScan meter. The table also provides possible solutions to the problems encountered.

ERROR MESSAGE	INDICATES	POSSIBLE CAUSE	CORRECTIVE ACTION
Err. 1 (in primary display)	Memory write error	Instrument too old (> 10 years) or hardware failure.	Turn OFF meter and turn it ON. Return to dealer if necessary.
Err. 2 (in primary display)	Memory checksum error	Hardware failure.	Turn OFF meter and turn it ON. Return to dealer if necessary.
Err. 3 (in primary display)	ADC error	Hardware error.	Turn OFF meter and turn it ON. Return to dealer if necessary.
Err. 4 (in primary display)	Keypad error	One or more keys on the keypad are stuck.	Turn OFF meter and turn it ON. Return to dealer if necessary.
Err. Annunciator	Wrong keypad input	Wrong input in selected mode.	Release key. Select valid operations depending on mode.
Electrode icon & buffer icon blinks & Err annunciator lights up	Calibration	Incorrect buffer used or contaminated buffer solution	Check if the right buffer was selected or use fresh buffer solution.
Battery icon lights up	Low Battery	Battery power is low	Replace batteries with fresh ones as soon as possible.

13 TROUBLE-SHOOTING

PROBLEM	PROBABLY CAUSE	REMEDIAL ACTION
Nothing is displayed when the ON/OFF key is selected.	<ol style="list-style-type: none"> 1. Batteries not in place. 2. Batteries (+ & - poles) not in correct polarity. 3. Weak batteries. 	<ol style="list-style-type: none"> 1. Insert batteries. 2. Re-insert batteries in the correct polarity. 3. Replace batteries or attach AC adapter.
Unstable reading	<ol style="list-style-type: none"> 1. Insufficient reference electrolyte in electrode. 2. Broken electrode. 3. External "noises" or induction (e.g. electrical 'noise' caused by a nearby motor). 4. Dirty electrode. 	<ol style="list-style-type: none"> 1. Fill electrode with reference electrolyte. 2. Replace electrode. 3. Remove or switch off interfering device. 4. Clean the electrode. Rejuvenate if necessary.
Slow responses.	<ol style="list-style-type: none"> 1. Dirty electrode. 	<ol style="list-style-type: none"> 1. Clean electrode. Rejuvenate if necessary.
Meter is not responding to key press.	<ol style="list-style-type: none"> 1. HOLD mode in operation. 2. Broken electrode. 3. Internal program error. 	<ol style="list-style-type: none"> 1. Cancel HOLD mode. 2. Replace electrode. 3. Reset all internal programs by re-inserting battery.

14 INFORMATION ON pH MEASUREMENT & ELECTRODE

The previous sections of this manual describe the various features of the instrument and practical aspects of its operation. This section provides a general description of pH measurement principles. It also provides tabulations of pH buffer changes with temperature. Lastly, it includes a list of available accessories.

14.1 pH Measurements

14.1.1 Liquid Junction Potential

The liquid - junction potential is the difference in potential created at the liquid - liquid phase boundary at the electrode tip, due to dissimilar composition of the test solution and the saturated KCl electrolyte. The sign and size of the liquid - junction potential depends upon the composition of the two solutions, the temperature and the geometry of the type of junction used.

When two solutions of different compositions come into contact, ion diffusion occurs at the point of contact.

When there is a high liquid junction potential, measured values differ greatly from the true value.

14.1.2 Asymmetry Potential

Within the glass electrode is an internal electrode that contains a reference solution of pH 7. When the electrode is placed in a pH 7 solution, the pH values within and outside the electrode are the same, and no potential ought to be produced. In practice, however, an electric potential called asymmetry potential, is generated.

It has been shown that asymmetry potential varies with the pH of the solution in contact with the glass, with age, with temperature, with the shape of the membrane, with the thickness of the membrane, with impurities in the reference solution, and any imperfections in the glass.

In addition, when the glass membrane dries out, the asymmetry potential increases and leads to measurement errors. That is why it is important to keep the glass hydrated prior to use, by soaking the electrode in a buffered solution or tap water. (Do not use de-ionized water). The purpose of soaking the glass electrode is to obtain a swollen low resistance glass surface and to stabilize the asymmetry potential of the electrode. This swollen surface is generally spoiled by drying, prolonged immersion in dehydrating solutions or chemical attack, such as etching by alkalis or hydrofluoric acid. Hence, it is necessary to work with a well-soaked glass electrode to ensure a constant asymmetry potential.

14.1.3 pH and Temperature

The electromotive force generated in the glass electrode varies with the temperature of the solution. As a result the response of the pH electrode is subjected to variations in temperature. Automatic Temperature Compensation compensates for this variance.

The temperature dependable of solutions vary considerably. Some may show an increase in pH while others a decrease for the same temperature variation. This is why when you are measuring pH values at a particular temperature, even with a pH meter having ATC, you must record the solution's temperature along with the pH value, or the measurement may be meaningless.

Temperature variation also cause variation in liquid junction potential, asymmetry potential, and the pH value of the reference solution. To reduce these factors, it is important to ensure that the temperature of the standard calibrating solution and the sample solution are the same.

14.2 Use of Standard pH Buffers

Standard pH buffer solutions are used to calibrate or standardize a pH meter before you measure the pH of a sample. They serve as reference standards for the basis of comparison between measurements.

The more common standard buffers are the pH 4.01, pH 7.00 and pH 10.01. The others include pH 1.68 and pH 12.45.

For 1-point calibration, you only need a general pH value. Use a standard buffer of pH 7.00 or a standard buffer whose pH value is close to that of the sample.

2-point calibration is used when you know that the sample is acidic or basic.

- For acidic sample: use standard buffers of pH 7.00 and pH 4.01
- For basic sample: use standard buffers of pH 7.00 and pH 10.01

3-point calibration is necessary when the sample's pH is completely unknown. All pH 7.00, pH 4.01 and pH 10.01 standard buffers should be used.

14.3 Standard pH Buffers

The following table shows the various pH values at different temperature of the solution during calibration.

Temperature (°C)	pH 1.68 (oxalate)	pH 4.01 (phthalate)	pH 7.00 (neutral Phosphate)	pH 10.01 (carbonate)	pH 12.45 (Saturated Calcium Hydroxide Solution)
0	1.67	4.01	7.12	10.32	13.43
5	1.67	4.01	7.09	10.25	13.21
10	1.67	4.00	7.06	10.18	13.00
15	1.67	4.00	7.04	10.12	12.81
20	1.68	4.00	7.02	10.06	12.63
25	1.68	4.01	7.00	10.01	12.45
30	1.69	4.01	6.99	9.97	12.29
35	1.69	4.02	6.98	9.93	12.13
40	1.70	4.03	6.97	9.89	11.99
45	1.70	4.04	6.97	9.86	11.84
50	1.71	4.06	6.97	9.83	11.70
55	-	4.08	6.97	9.81	-
60	-	4.10	6.98	9.79	-
70	-	4.12	6.99	9.76	-
80	-	4.16	7.00	9.74	-
90	-	4.20	7.02	9.73	-

15 LIST OF ACCESSORIES

15.1 Replacement Meter and Meter accessories

Ordering Code No.	Item
EC-PH10/01N	Basic CyberScan pH 10 hand-held meter (pH/mV/°C) complete with 1 pc of temperature probe (EC-pH-TEM01P) and 2 pcs of electrode holders (15X000700)
EC-PH100/01N	Deluxe CyberScan pH 10 hand-held meter (pH/Rel mV/mV/°C/R232C) with communication interface. Complete with 1 pc of temperature probe (EC-pH-TEM01P), 2 pcs of electrode holders (15X000700), 1 pc of communication cable (EC-CA01M09F09) and 1 pc Data Acquisition Software in CD-ROM (EC-DA-2000).
EC-PH-TEM01P	Temperature probe for CyberScan pH 10 and pH 100 meters.
15X000700	Electrode holder for CyberScan hand-held meters.
EC-FE72521-01B	General purpose epoxy-body pH combination electrode, <u>single-junction</u> , 12x110 mm, 1-m cable length.
EC-FE72522-01B	General purpose epoxy-body pH combination electrode, <u>double-junction</u> , 12x110 mm, 1-m cable length.
EC-FE73528-01B	"3-in-1" pH/Temperature (ATC) combination epoxy-body electrode, 12x110 mm, 1-m cable length.
EC-CA01M09F09	CyberScan to PC communication cable – 9-pin male to 9-pin female connector, 1-m cable length.
EC-DA-2000	DAS (Windows® version – CyberComm Portable) for CyberScan pH 100 & CON 200 & DAS for Bench meters.
EC-PH-CYBERKIT	pH kit for pH 10 & pH 100 meter – Plastic carrying case comprises of 1 pc deionized water bottle (480 ml, empty), 1 x pH 4.01, pH 7.00 & pH 10.01 buffer sachets (20-ml), 4 pcs calibration jars (30-ml, empty), & 1 pc rinse/waste water bottle (480-ml, empty).
EC-POUCH-02	Carrying pouch for CyberScan hand-held meter.
EC-120-ADA	120 VAC power adapter (120 VAC/9 VDC, 50/60 Hz), 2-pin type
EC-220-ADA	220 VAC power adapter (220 VAC/9 VDC, 50/60 Hz), 2-pin type

For a list of other pH, ORP and ISE electrodes, refer to Section 15.3 and 15.4 for more information.

15.2 Calibration Solutions

Ordering Code No.	Item
EC-BU-4BX	pH 4.01 buffer tablets (box of 100 tablets, 10 strips X 10 tablets)
EC-BU-7BX	pH 7.00 buffer tablets (box of 100 tablets, 10 strips X 10 tablets)
EC-BU-10BX	pH 10.01 buffer tablets (box of 100 tablets, 10 strips X 10 tablets)
EC-BU-1BT	pH 1.68 buffer solution, 480 ml bottle
EC-BU-4BT	pH 4.01 buffer solution, 480 ml bottle
EC-BU-7BT	pH 7.00 buffer solution, 480 ml bottle
EC-BU-10BT	pH 10.01 buffer solution, 480 ml bottle
EC-BU-12BT	pH 12.45 buffer solution, 480 ml bottle
EC-BU-4BS	pH 4.01 buffer sachets, 20 ml x 20 pcs.
EC-BU-7BS	pH 7.00 buffer sachets, 20 ml x 20 pcs.
EC-BU-10BS	pH 10.01 buffer sachets, 20 ml x 20 pcs.
EC-RIN-WT	pH De-ionized water rinse sachets, 20 ml x 20 pcs
EC-AST-PK	pH sachet assortment pack – 5 each of pH 4.01, pH 7.00, pH 10.01 and de-ionized water sachets per box.
EC-DPC-BT	Protein cleaning solution for pH electrode
EC-RE-005	Storage solution for pH electrode
EC-ORP-PRE	Pre-treatment solution for ORP measurement (475 mV), 480-ml bottle
EC-ORP-QUIN	Quinhydrone 255 (255 mV, ± 15 mV @ 25 °C) for ORP measurement
EC-ORP-QUIN086	Quinhydrone 86 (86 mV) for ORP measurement

Note: pH buffer solutions (480-ml bottle) have ± 0.01 pH accuracy at 25 °C.

Sachets are individually sealed, single use pouch containing 20 ml of fresh, contamination free calibration solution. pH buffer sachets have ± 0.01 pH accuracy at 25°C and conductivity sachets have $\pm 1\%$ accuracy at 25°C.

15.3 Ion Selective Electrodes (ISE)

Ask our distributors for more details regarding Ion Selective Electrodes. The table below lists the range of electrodes available.

Ion
Ammonia (NH ₃)
Ammonium (NH ₄ ⁺)
Bromide (Br ⁻)
Cadmium (Cd ⁺²)
Calcium (Ca ⁺²)
Carbon Dioxide (CO ₂)
Chloride (Cl ⁻)
Copper (Cu ⁺²)
Cyanide (CN ⁻)
Fluoride (F ⁻)
Fluoroborate (BF ₄ ⁻)

Ion
Lead (Pb ⁺²)
Lithium (Li ⁺)
Nitrate (NO ₃ ⁻)
Nitrogen Oxide (NO _x)
Perchlorate (ClO ₄ ⁻)
pH (H ⁺)
Silver/Sulfide (Ag ⁺ /S ⁻²)
Sodium (Na ⁺)
Sulfur Dioxide (SO ₂)
Surfactant (X ⁻ , X ⁺)
Thiocyanate (SCN ⁻)

15.4 pH & ORP Electrodes

There is a wide range of electrodes for the user's applications. A sampling is shown below. Note that although only one electrode for each application is shown, there are multiple electrodes available and these electrodes are often multi-application adaptable.

APPLICATION	ELECTRODE
General purpose, aqueous pH measurements. Quality control, general laboratory and aquarium water.	EC-FG73504
Tris buffers, clinical and biological media containing proteins, creams, fats and cosmetics.	EC-FG73905
Research measurements, fruit juices, beer, milk and yogurt.	EC-FG73905
High viscosity measurements such as emulsions, suspensions, paints and varnishes.	EC-FG63506
Non aqueous solutions	EC-FG73701
Low temperature measurements	EC-FG73504
Low ionic strength solutions	EC-FG73905
High temperature measurements	EC-FG73792
Surface measurements such as paper, skin textile, leather and agar plates	EC-FG72520
Solid or semi-solid samples such as cheese, meats, fruits, bread, etc.	EC-FG63511
Portable pH meters, school and field use	EC-FE73526
Micro samples (semi-micro curettes and NMR tubes)	EC-FG43901
Test tube measurements	EC-FG63507
Reference contamination problems	EC-FG73701
Measurements in long narrow vessels	EC-FG63507
Swimming pool pH control under continuous flow conditions	EC-FE73526
Isoelectric focusing gels and other surface measurements that require small diameter flat tip	EC-FG52910
Photographic chemicals, high pH samples (12 to 14 pH)	EC-FG74519
ORP measurements for general purpose	EC-FG79601
Swimming pool ORP measurements	EC-FE79602
ORP measurements for cyanide use	EC-FG78685
ORP measurements requiring double junction reference	EC-FG79861
Hydrofluoric acid and abrasive solution measurements	EC-FE77689
Potentiometric measurements of chlorides and other halides. Bio-technology, steam sterilizable.	EC-FG70601

16 METER SPECIFICATIONS

SPECIFICATIONS	pH 10	pH 100
pH Range	0.00 to 14.00 pH	-2.00 to 16.00 pH
Resolution	0.01 pH	0.01/0.1 pH (Selectable)
Accuracy	± 0.01 pH	± 0.01/0.1 pH
Slope Range	80% to 120%	80% to 120%
Temperature Range	0.0 to 100.0 °C	0.0 to 100.0 °C
Resolution	0.1 °C	0.1 °C
Accuracy	± 0.5 °C	± 0.5 °C
Millivolt Range (400 mV)	-400 to +400 mV	-400 to +400 mV
Resolution	0.1 mV	0.1 mV
Accuracy	± 0.2 mV	± 0.2 mV
Millivolt Range (2000 mV)	-2000 to +2000 mV	-1600 to +1600 mV
Resolution	1 mV	1 mV
Accuracy	± 2 mV	± 2 mV
No. Of Calibration Points	1 to 3 points	1 to 5 points
No. Of pH Buffer Values	3	5
pH Buffer Options	pH 4.01, 7.00, & 10.01	pH 1.68, 4.01, 7.00, 10.01, 12.45
Relative mV functions		Yes
Relative mV offset display		Yes
Slope Display		Yes
Offset Display		Yes
Memory		16 data sets
Outputs		RS232C
Auto Shut-off	Yes (20 minutes)	Selectable
Averaging/Stability (READY)	Yes	Selectable
Display	Dual LCD	Dual LCD
Hold Function	Yes	Yes
ATC Function	0.0 to 100.0 C	0.0 to 100.0 C
Inputs	BNC, Phono, Power jack	BNC, Phono, Power jack
Power Requirements	4 'AAA' Batteries; AC/DC Adapter 9 V, 500 mA	4 'AAA' Batteries; AC/DC Adapter 9 V, 500 mA
Battery Life	> 50 hours	> 50 hours
Environmental Requirements	0 to 50 °C	0 to 50 °C
Operating Range	0 to 50 °C	0 to 50 °C
Dimensions; Weight	Meter: 18 x 9 x 4 cm; 220 g Boxed: 24 x 23 x 7 cm; 600 g	

17 ADDENDUM 1: FACTORY DEFAULT SETTINGS (pH 100 ONLY)

PROGRAM	FUNCTION	ACTIVE KEYS	OPTIONS	DEFAULT SETTING
P 1.0	Memory Clear	MI/▲; MR/▼	ON ; OFF	OFF
P 1.1	Reset	MI/▲; MR/▼	ON ; OFF	OFF
P 2.0	Electrode Offset	-	Viewing Only	0.0 mV
P 2.1	Electrode Slope	-	Viewing Only	100.0
P 2.2	pH Calibration Buffer Data Display	MI/▲; MR/▼	1.68; 4.01; 7.00; 10.01; 12.45 (Viewing only)	" ——" No calibration performed.
P 2.3	Last pH Calibration Temperature	-	Viewing Only	25.0 C
P 2.4	Relative mV Offset	-	Viewing Only	0.00 mV
P 3.0	Resolution - [pH] mode	MI/▲; MR/▼	0.1 ; 0.01	0.01
P 3.1	READY Selection	MI/▲; MR/▼	ON; OFF	ON
P 3.2	Auto Shut-Off	MI/▲; MR/▼	ON; OFF	ON
P 4.0	Baud Rate	MI/▲; MR/▼	2.4; 4.8; 9.6; 19.2 (Kbps)	9.6 Kbps
P 4.1	Parity	MI/▲; MR/▼	0,1,2 (none, odd, even)	2 (even)
P 4.2	Stop Bit	MI/▲; MR/▼	1,2	1

NOTE: The CON key is always active. It is used to confirm all program functions selected.

18 WARRANTY & RETURN OF ITEMS

Eutech Instruments warrants this meter to be free from significant deviations in material and workmanship for a period of three years from date of purchase. Eutech Instruments warrants this probe to be free from significant deviations in material and workmanship for a period of six months from date of purchase. Each instrument will have a warranty card with a specific serial number. The warranty card must be endorsed by the Authorized Distributor at the point of sale.

If repair or adjustment is necessary and has not been the result of abuse or misuse within the designated period, please return – freight pre-paid – and correction will be made without charge. Eutech Instruments alone will determine if the product problem is due to deviations or customer misuse.

Out of warranty products will be repaired on a charged basis.

Exclusions

The warranty on your instrument shall not apply to defects resulting from:

- Improper or inadequate maintenance by customer
- Unauthorized modification or misuse
- Operation outside of the environment specifications of the products

Return of Items

Authorization must be obtained from our Customer Service Department or authorized distributor before returning items for any reason. A "Return Goods Authorization" (RGA) form is available through our authorized distributor. Please include data regarding the reason the items are to be returned. For your protection, items must be carefully packed to prevent damage in shipment and insured against possible damage or loss. Eutech Instruments will not be responsible for damage resulting from careless or insufficient packing. A restocking charge will be made on all unauthorized returns.

NOTE: Eutech Instruments Pte Ltd reserves the right to make improvements in design, construction, and appearance of products without notice.

For more information on Eutech Instruments products, contact your nearest Eutech Instruments distributor or visit our website listed below:

Manufactured by:

Eutech Instruments Pte Ltd.

Blk 55, Ayer Rajah Crescent,

#04-14/24 Singapore 139949

Tel: (65) 6778 6876

Fax: (65) 6773 0863

E-mail: marketing@eutechinst.com

Web-site: <http://www.eutechinst.com>

Distributed by: