

# Instruction Manual

# Temp JKT

## Temperature Meter Series



**OAKTON®**



**EUTECH  
INSTRUMENTS**

*Technology Made Easy...*

**ISO 9001**  
CERTIFIED

68X243615

Rev. 3 06/06

## **Preface**

This manual serves to explain the use of the Temp JKT temperature meter. This manual functions in two ways: first, as a step by step guide to help you operate the meter; second, it serves as a handy reference guide.

This manual is written to cover as many anticipated applications of the Temp JKT meter as possible. If there are doubts in the use of the Temp JKT meter, do not hesitate to contact the nearest Eutech Instruments Authorized Distributor.

Eutech Instruments/ Oakton Instruments will not accept any responsibility for damage or malfunction to the meter caused by improper use of the instrument.

The information presented in this manual is subjected to change without notice as improvements are made, and does not represent a commitment on the part of Eutech Instruments Pte Ltd/ Oakton Instruments.

Copyright © 1999

Eutech Instruments Pte Ltd/ Oakton Instruments

# TABLE OF CONTENTS

<b><u>1.</u></b>	<b><u>INTRODUCTION</u></b>	<b><u>1</u></b>
1.1	Introducing the Temp JKT	1
<b><u>2.</u></b>	<b><u>GETTING STARTED</u></b>	<b><u>2</u></b>
2.1	Description of Keypad Functions	2
2.2	Description of LCD Annunciators	2
2.3	Inserting & Removing the Rubber Boot	3
2.4	Inserting New Batteries	4
2.5	Battery Replacement	5
2.6	Connecting the Temperature Sensor	5
2.7	Switching the Meter On	5
<b><u>3.</u></b>	<b><u>CALIBRATION</u></b>	<b><u>6</u></b>
3.1	Temperature Calibration	6
<b><u>4.</u></b>	<b><u>MEASUREMENT</u></b>	<b><u>8</u></b>
4.1	Taking Measurements	8
4.2	Displaying Maximum and Minimum Readings	8
4.3	Holding a Reading	8
4.4	Releasing a Held Reading	8
4.5	Maximum and Minimum Hold Mode	9
<b><u>5.</u></b>	<b><u>DISABLE AUTO POWER OFF FEATURE</u></b>	<b><u>10</u></b>
<b><u>6.</u></b>	<b><u>PROBE CARE AND MAINTENANCE</u></b>	<b><u>11</u></b>
<b><u>7.</u></b>	<b><u>TROUBLESHOOTING</u></b>	<b><u>11</u></b>
<b><u>8.</u></b>	<b><u>SPECIFICATIONS</u></b>	<b><u>12</u></b>
<b><u>9.</u></b>	<b><u>ACCESSORIES</u></b>	<b><u>13</u></b>
<b><u>10.</u></b>	<b><u>WARRANTY</u></b>	<b><u>14</u></b>
<b><u>11.</u></b>	<b><u>RETURN OF ITEMS</u></b>	<b><u>15</u></b>

# 1. INTRODUCTION

## 1.1 *Introducing the Temp JKT*

Thank you for purchasing the Temp JKT meter. This economical microprocessor-based handheld meter works with type J, type K and type T probes for a wide temperature measurement range:

- **Type J probes** (iron-constantan) offer a wide range of  $-200$  to  $1000$  °C /  $-328$  to  $1832$  °F; use in reducing environments
- **Type K probes** (chromel-alumel) offer the widest range of  $-250$  to  $1372$  °C /  $-418$  to  $2502$  °F; use in oxidizing environments
- **Type T probes** (copper-constantan) of range of  $-250$  to  $400$  °C /  $-418$  to  $752$  °F; good for ambient and sub-freezing measurements

The Temp JKT meter features:

- Large LCD for clear and easy reading
- Readings in °C and °F (selectable)
- Minimum and maximum temperature display
- Minimum and maximum hold mode
- Low battery indicator
- Hold function, freezes measured reading
- User calibration - offset adjustment
- Built-in memory backup; calibration and other information remain if battery is disconnected

This instruction manual is organized for quick reference with step-by-step procedures that give you thorough review of the various features and meter operations.

Included with your meter are a rubber boot, 4 alkaline “AAA” batteries, an instruction manual and a warranty card. To order different type of thermocouple probes, please refer to Section on Accessories for more information.

## 2. GETTING STARTED

### 2.1 Description of Keypad Functions

Temp JKT meter has seven keys on its splash-proof keypad. These keys include ON / OFF, CAL, HOLD / ENTER, °C/°F, MAX/▲ or MIN/▼ key and J-K-T keys.

**ON/OFF:** Powers meter on and shuts the unit off. Meter directly enters measurement mode when you turn it on.

**CAL:** Allows temperature calibration of the meter.

**HOLD/ENTER:** Freezes the measured reading; confirm calibration value.

**MAX/▲ (UP) or MIN/▼ (DOWN):** Momentarily displays meter's maximum and minimum temperature; enter maximum or minimum hold mode; scroll up and down in calibration mode.

**°C/°F:** Switches between °C and °F in measurement mode.

**J-K-T:** Switches between J, K and T thermocouple measurement mode.

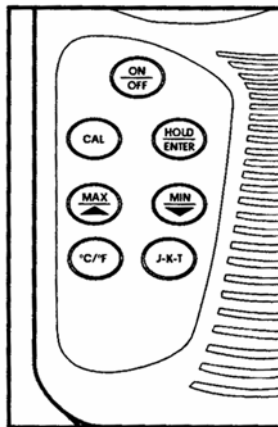

Figure 1:

### 2.2 Description of LCD Annunciators

The EcoScan Temp JKT meter has a large custom LCD that consists of 4-digit segments and operation annunciators for °C and °F. Other indicators include "MIN", "MAX", "HO" (when the HOLD function is activated), "LO" (low battery condition) and "J"/"K"/"T".



Figure 2: Full segment LCD

### **2.3 Inserting & Removing the Rubber Boot**

1. To remove meter from rubber boot, push out from the bottom edges of meter until it is completely out of boot. Ensure that the connector of temperature sensor is not connected.
2. To insert meter into rubber boot, slide in from the top of meter before pushing the bottom edges of meter down to set it into position. Lift up the stand at the back of meter for bench top applications if necessary.



**Figure 3: Inserting meter into the rubber boot**

## **2.4 Inserting New Batteries**

The battery compartment is found at the back of instrument. To open the battery compartment, push in the direction of arrow and lift up the cover. Note the polarity of battery before inserting into position. After replacement, place cover back and press down until it locks tight.

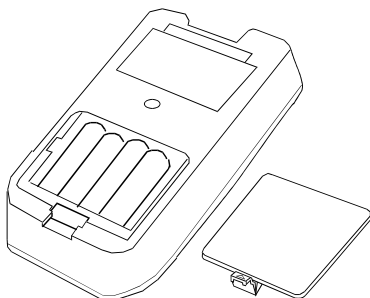

**Figure 4: Battery compartment at the back of the meter**

## 2.5 Battery Replacement

A “LO” annunciator in the LCD alerts you when battery power is running low. Replace with the same type as recommended by the manufacturer.



Figure 5: Low battery indicator

**Caution:** Power off the meter when changing battery.

## 2.6 Connecting the Temperature Sensor

Insert the 2-pin mini connector plug of the temperature sensor into the connector socket on the side of the meter.

**NOTE:** The negative pin is larger than the positive pin, be sure to properly align the pins. Unplug the sensor when not in use.

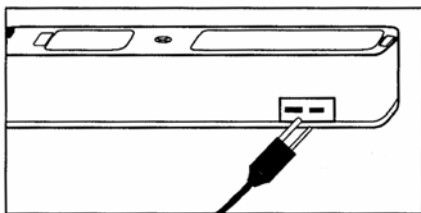

Figure 6: Connecting the temperature sensor

## 2.7 Switching the Meter On

1. Press **ON/OFF** key to power up your meter. All the LCD segments display momentarily as the meter performs a self-diagnostic test, per shown in section 2.2. The LCD then switches into measurement mode.



Figure 7: "Open"

2. The LCD displays “oPEn” if the temperature sensor is faulty, or there is an open circuit. Please refer to section on Troubleshooting if in doubt.

## 3. CALIBRATION

### 3.1 Temperature Calibration

The temperature sensor included with your meter is factory calibrated. Over time, the temperature calibration may drift and the probe requires re-calibration. The Temp JKT meter allows you to have a 1-point calibration as fine adjustment by changing its offset value. This is useful if you replace the probe. If you replace the probe, you should recalibrate.

1. First connect the temperature probe to the meter. Press **ON/OFF** key to power up the meter and wait for meter to enter measurement mode.
2. Dip the probe in a constant temperature bath, or in liquid whose temperature can be checked with an accurate thermometer. For best accuracy, place the probe and thermometer in a constant temperature bath.
3. Wait for readings to stabilise.
4. To enter temperature calibration mode, press and hold **CAL** key for 5 seconds before release. The LCD shows "**CA**" momentarily and a value flashes.
5. Press **MAX/▲** or **MIN/▼** key to adjust the displayed value until it matches the correct temperature. The **MAX/▲** or **MIN/▼** key will scroll to the maximum allowable value.

*NOTE: The maximum adjustments allowed for the following meter series from factory default are:*

- *EcoScan JKT Temperature meters =  $\pm 10$  °C*
- *EcoScan 4/5/6 Temperature meters =  $\pm 5$  °C*

6. Press **ENTER** key to confirm calibration.
7. The LCD displays "**CO**" momentarily, and the meter then reverts to measurement mode. See figure below.

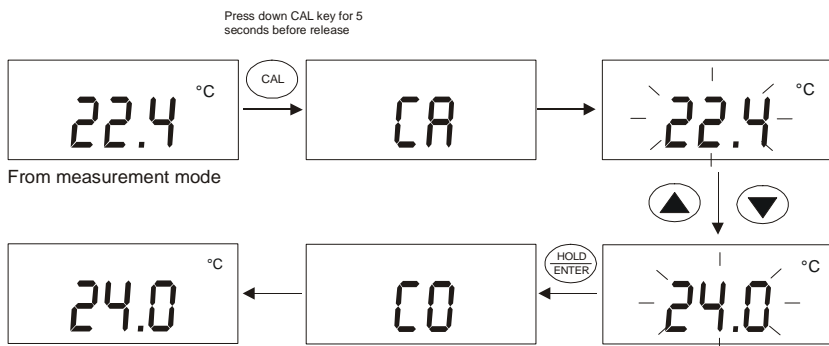

**Figure 8: Temperature calibration**

## 4. MEASUREMENT

### 4.1 Taking Measurements

1. Power on the meter. The meter automatically enters Temperature mode. The "J", "K" or "T" annunciator will display, depending on what probe type was selected the last time the meter was used. The °C or °F annunciator display in your LCD indicate which mode you are taking measurements in.
2. Press the **J-K-T** key to toggle between type J, K or T mode, until the mode matches probe type selected. Note reading.
3. Press the **°C/°F** key to toggle between each measurement mode.



Figure 10: J/K/T and temperature annunciators

### 4.2 Displaying Maximum and Minimum Readings

The Temp JKT meter can momentarily display the maximum and minimum temperature measured since you switched the meter on. Simply press **MAX/▲** or **MIN/▼** key. The "MAX" or "MIN" annunciator displays in the LCD and the maximum or minimum temperature momentarily displays. Meter then returns to measurement mode.



Figure 11: Viewing the maximum & minimum value

### 4.3 Holding a Reading

To freeze or hold your reading, press **HOLD** key once. The LCD displays "HO" annunciator to indicate the HOLD function is activated.



Figure 12: HOLD

### 4.4 Releasing a Held Reading

Press **HOLD** key again to deactivate HOLD function or to release your frozen reading. The meter returns to measurement mode, and the "HO" annunciator disappears from the LCD.

#### 4.5 Maximum and Minimum Hold Mode

With the Maximum and Minimum Hold mode, the Temp JKT meter can be used as a maximum registering (or minimum registering) thermometer. The meter displays the lowest or highest temperature measured since entering the Maximum or Minimum Hold mode.

1. Power on the meter. The meter automatically enters temperature mode. Use °C/°F key to switch between Celcius and Fahrenheit reading if desired.
2. Press **HOLD** key. The reading freezes and the annunciator “**HO**” displays in the LCD.
3. Press **MAX/▲** or **MIN/▼** key. Meter enters the Maximum or Minimum Hold mode. “**HO**” and “**MAX**” or “**MIN**” annunciator displays in the LCD.



Figure 13: Maximum & minimum HOLD mode

Meter will now continuously display the lowest or highest temperature measured since you entered this mode. It will update the display when new highs or lows are reached.

Press **HOLD** key again to leave MIN/MAX Hold mode and meter returns to its measurement mode.

## 5. DISABLE AUTO POWER OFF FEATURE

By default this meter will auto power-off 17 minutes after last key operation. This is to conserve battery power. The auto power-off feature can be disabled in situation where longer periods of monitoring are desired.

*NOTE: The meter switches back to auto power-off mode as soon as it is turned off.*

### Procedure:

1. With meter off, press down **ON/OFF** and **MIN/▼** keys together.
2. Release **ON/OFF** key first and wait for 2 seconds before releasing **MIN/▼** key.
3. The meter goes through the power-up sequence before coming to measurement mode.
4. The “LO” indicator will blink, indicating that the auto power-off feature is disabled.

*NOTE: When battery is low, the “LO” indicator will blink faster at every 1 second. Otherwise, it blinks every 2 seconds.*

Once the meter is switched off and subsequently switched on again, the auto power-off feature will be enabled.

*NOTE: Under default operation (when auto power-off feature is enabled), the appearance of “LO” indicator permanently on the display means the battery power is low. Once a new battery is installed, the “LO” indicator will disappear*

The “LO” indicator will blink, indicating that the auto power-off feature is disabled

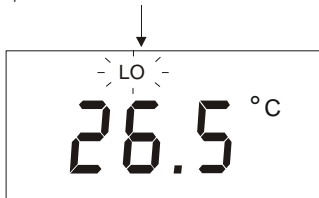

## 6. PROBE CARE AND MAINTENANCE

For best results, always clean the temperature probe with clean tissue paper after measurement to keep the probe in good working condition. Wash the probe thoroughly with tap water if necessary to wash off any residue. Should there be any thin oil film sticking on the probe, wash with mild detergent or soap and warm water. Rinse probe thoroughly under running water. Blot it dry and clean off with clean tissue.

To remove the probe, simply hold firmly onto the probe's plastic holder and pull the connector out of the meter's socket. Store both the probe and meter into its original packaging when not in use.

## 7. TROUBLESHOOTING

Problem	Cause	Solution
Power on but no display	a) Batteries not in place.	a) Insert batteries. b) Re-insert batteries in correct polarity.
"oPEn" display on LCD	a) Probe not connected	a) Make sure probe is firmly connected.
"Ur" or "Or" display on LCD	a) Measurement over (Or) or Under (Ur) range	a) Ensure temperature taken is within meter's specification.
"LO" annunciator in the LCD	a) Low battery	a) Replace batteries with fresh ones.
Unstable reading	a) Electrode not deep enough in sample b) Dirty probe c) Broken probe d) External "noises" or induction caused by nearby electrical motor	a) Place probe deeper in sample. b) Clean probe. c) Replace electrode. d) Remove or switch off interfering motor.
Slow response	a) Dirty probe	a) Clean probe

## 8. SPECIFICATIONS

<b>Temperature Range</b> Type J Type K Type T	-200 to 1000 °C (-328 to 1832 °F) -250 to 1372 °C (-418 to 2502 °F) -250 to 400 °C (-418 to 752 °F)
<b>Resolution</b> t<-99.0 °C -99.9 °C<t<299.9 °C t>299.9 °C	1 °C (1 °F) 0.1 °C (0.1 °F) 1 °C (1 °F)
<b>Accuracy</b> t<-99.9 °C t>-99.9 °C	± 0.25% of reading + 1 °C (2 °F) ±0.2% of reading + 0.5 °C (0.9 °F)
Offset Adjustment	±10 °C (±18 °F)
Auto Power-Off	17 minutes after last key-press
Hold Function	Yes
Display	Custom LCD
Low Battery Indicator	Yes
Input	2-pin ANSI mini connector
Power Requirement	4 'AAA' Batteries
Battery Life	>200 hours
Operating Temperature	-10 to +50 °C
Dimension / Weight	Meter: 14 x 7 x 3.5 cm / 200 g Boxed: 24 x 17 x 8 cm / 550 g

## 9. ACCESSORIES

### Replacement Meter and Meter accessories

Item	Eutech Instruments	Oakton Instruments
	Ordering Code	Ordering Code
Temp JKT meter only	EC-TEMPJKT	35627-00
General purpose probe (immersion into liquids), type J	EC-TPGLPJ-01M	08517-55
Penetration probe (meat, semi-soft materials), type J	EC-TPPENJ-01M	08517-65
Surface probe (direct contact on hot surface), type J	EC-TPSURJ-01M	08517-60
Clip-on probe (surface contacts – electronics), type J	EC-TPCLPJ-01M	08469-00
General purpose probe (immersion into liquids), type K	EC-TPGLPK-01M	08516-55
Penetration probe (meat, semi-soft materials), type K	EC-TPPENK-01M	08516-65
Surface probe (direct contact on hot surface), type K	EC-TPSURK-01M	08516-60
Clip-on probe (surface contacts – electronics), type K	EC-TPCLPK-01M	08469-02
Replacement Boot	~	35627-80
Replacement AAA Batteries	~	09376-00

## 10. WARRANTY

This meter is supplied with a warranty against significant deviations in material and workmanship for a period of **THREE** years from date of purchase whereas probe with a **SIX**-month warranty.

If repair or adjustment is necessary and has not been the result of abuse or misuse within the designated period, please return – freight pre-paid – and correction will be made without charge. Eutech Instruments/ Oakton Instruments will determine if the product problem is due to deviations or customer misuse.

Out of warranty products will be repaired on a charged basis.

### Exclusions

The warranty on your instrument shall not apply to defects resulting from:

- Improper or inadequate maintenance by customer
- Unauthorized modification or misuse
- Operation outside of the environment specifications of the products

## **11. RETURN OF ITEMS**

Authorization must be obtained from our Customer Service Department or authorized distributor before returning items for any reason. A "Return Goods Authorization" (RGA) form is available through our authorized distributor. Please include data regarding the reason the items are to be returned. For your protection, items must be carefully packed to prevent damage in shipment and insured against possible damage or loss. Eutech Instruments/ Oakton Instruments will not be responsible for damage resulting from careless or insufficient packing. A restocking charge will be made on all unauthorized returns.

NOTE: Eutech Instruments Pte Ltd/ Oakton Instruments reserves the right to make improvements in design, construction, and appearance of products without notice.

## NOTES

For more information on Eutech Instruments/ Oakton Instruments' products, contact your nearest distributor or visit our website listed below:

<p><b>Oakton Instruments</b> P.O Box 5136, Vernon Hills, IL 60061, USA Tel : (1) 888-462-5866 Fax: (1) 847-247-2984</p> <p>E-mail: <a href="mailto:info@4oakton.com">info@4oakton.com</a> Web-site: <a href="http://www.4oakton.com">www.4oakton.com</a></p>	<p><b>Eutech Instruments Pte Ltd.</b> Blk 55, Ayer Rajah Crescent, #04-16/24 Singapore 139949 Tel: (65) 6778 6876 Fax: (65) 6773 0836 E-mail: <a href="mailto:marketing@eutechinst.com">marketing@eutechinst.com</a> Web-site: <a href="http://www.eutechinst.com">www.eutechinst.com</a></p>	<p><b>Distributed by:</b></p>
--	---	-------------------------------